

# Product data sheet

## Subminiature connectors



Product description **Bayonet Female panel mount connector, Contacts: 5, unshielded, solder, IP40**

Area **Bayonet series 710**

Part no. **09 0998 00 05**

### Illustration



### Scale drawing

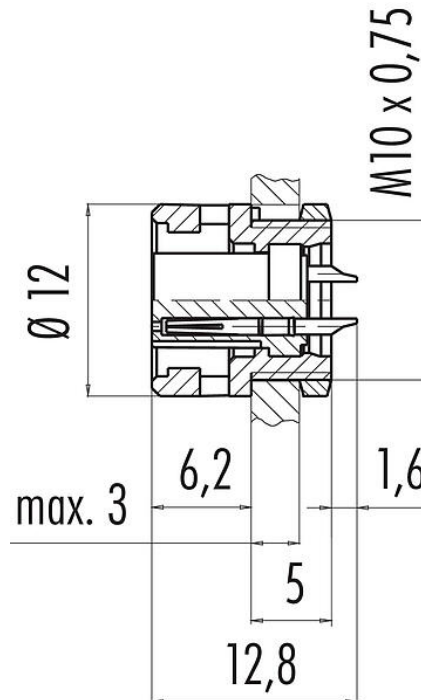

### Contact arrangement (Plug-in side)

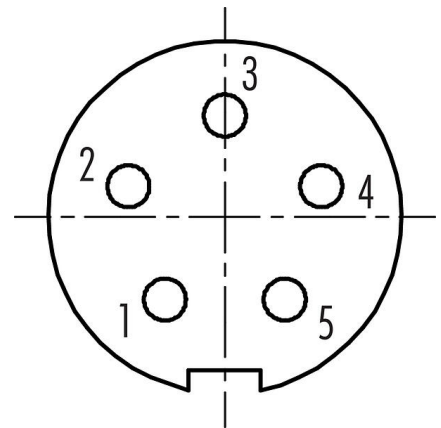

You can find the component part drawing and assembly instructions on the next page.

### Technical data

#### General features

Part no.	<b>09 0998 00 05</b>
Connector design	Female panel mount connector
Version	Connector socket straight
Connector locking system	Bayonet
Termination	solder
Degree of protection	IP40
Cross-sectional area	0.25 mm <sup>2</sup> / AWG 24
Temperature range from/to	-40 °C / 85 °C
Mechanical operation	> 500 Mating cycles
Weight (g)	1.72
Customs tariff number	85369010

#### Electrical parameters

Rated voltage	125 V
Rated impulse voltage	1500 V
Rated current (40 °C)	3,0 A

Product description **Bayonet Female panel mount connector, Contacts: 5, unshielded, solder, IP40**

Area **Bayonet series 710**  
Part no. **09 0998 00 05**

Insulation resistance	$\geq 10^{10} \Omega$
Pollution degree	1
Overvoltage category	II
Insulating material group	III
EMC compliance	unshielded

### Material

Housing material	PA
Contact body material	PA (UL94 V-0)
Contact material	CuSn (bronze)
Contact plating	Au (gold)
REACH SVHC	CAS 7439-92-1 (Lead)
SCIP number	b61916db-2a8a-4852-b261-f3a137dc058f

### Classifications

eCl@ss 11.1	27-44-01-09
ETIM 7.0	EC003569

### Assembly instructions / Panel cut-out

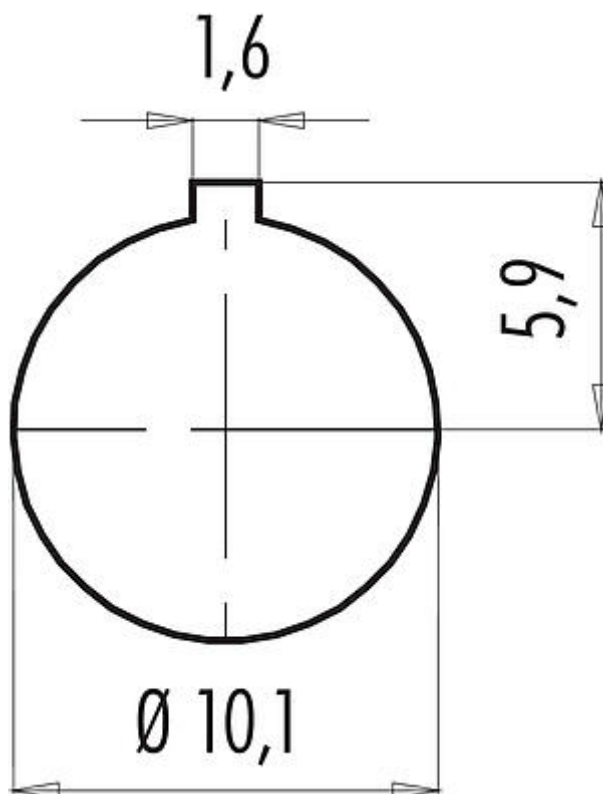

Product description **Bayonet Female panel mount connector, Contacts: 5, unshielded, solder, IP40**

Area **Bayonet series 710**  
Part no. **09 0998 00 05**

**Component part drawing**

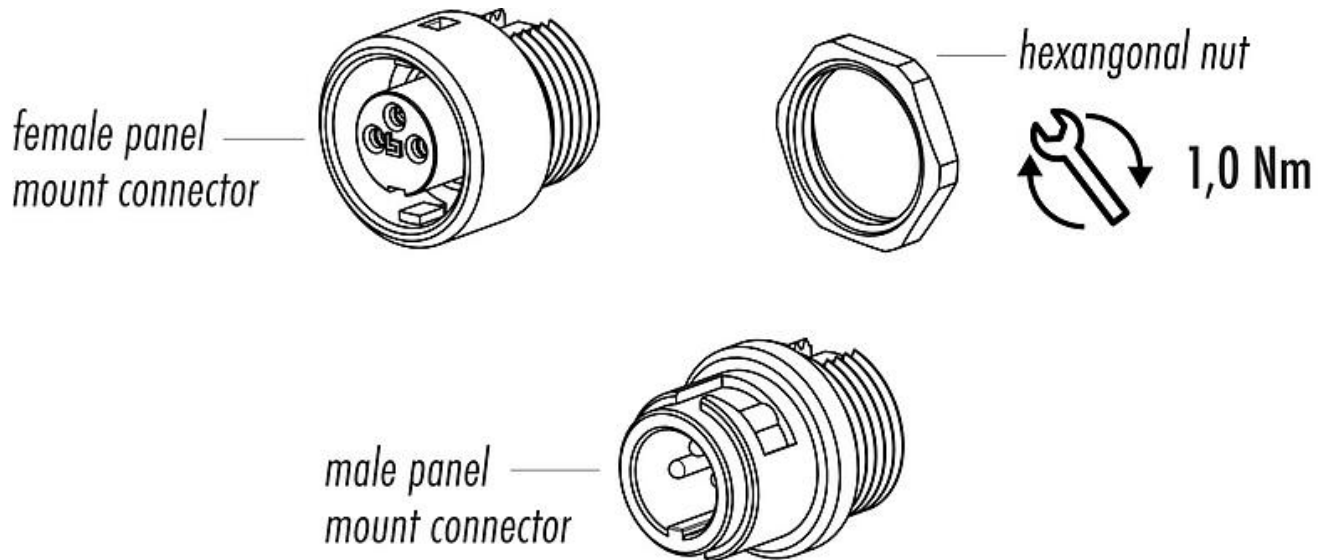

Product description	<b>Bayonet Female panel mount connector, Contacts: 5, unshielded, solder, IP40</b>
Area	<b>Bayonet series 710</b>
Part no.	<b>09 0998 00 05</b>

### **General Disclaim Notice**

The connector must not be plugged or unplugged under load. Non-observance and improper use can result in personal injury.

The connectors have been developed for applications in plant engineering, control and electrical equipment construction. The user is responsible for checking whether the connectors can also be used in other areas of application.