

Product description	M12-A Female angled connector, Contacts: 4, 2.5-3.5 mm, unshielded, screw clamp, IP67
Area	M12-A series 713
Part no.	99 0430 324 04

### Illustration

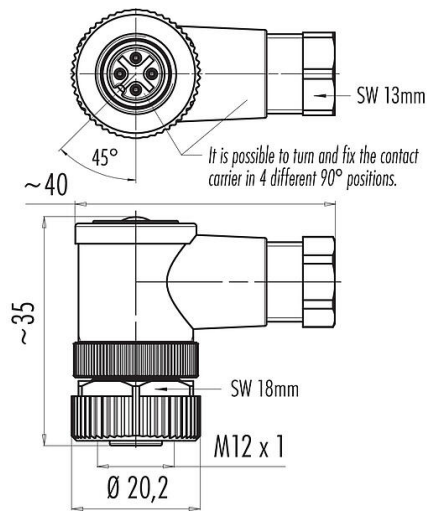

### Scale drawing



### Contact arrangement (Plug-in side)

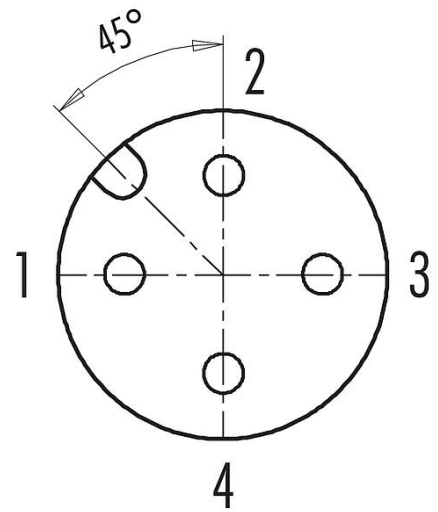

You can find the component part drawing and assembly instructions on the next page.

### Technical data

#### General features

Part no.	<b>99 0430 324 04</b>
Connector design	Female angled connector
Version	Connector socket angled
Connector locking system	screw
Termination	screw clamp
Degree of protection	IP67
Cross-sectional area	max. 0.75 mm <sup>2</sup> / AWG 18
Cable outlet	2.5-3.5 mm
Twistability	90° (4 coding options)
Temperature range from/to	-40 °C / 85 °C
Mechanical operation	> 50 Mating cycles
Weight (g)	24.67
Customs tariff number	85369010

#### Electrical parameters

Rated voltage	250 V
Rated impulse voltage	2500 V
Rated current (40 °C)	4.0 A
Insulation resistance	> 10 <sup>9</sup> Ω
Pollution degree	3

# Product data sheet

## Automation technology - sensors and actuators



Product description	<b>M12-A Female angled connector, Contacts: 4, 2.5-3.5 mm, unshielded, screw clamp, IP67</b>
-	-
Area	<b>M12-A series 713</b>
Part no.	<b>99 0430 324 04</b>

Overvoltage category	II
Insulating material group	III
EMC compliance	unshielded

### Material

Housing material	PA
Contact body material	PA
Contact material	CuZn (brass)
Contact plating	CuSnZn (Optalloy)
Locking material	Zinc die-cast nickel-plated
REACH SVHC	CAS 7439-92-1 (Lead)
SCIP number	SCIP-number not available

### Classifications

eCl@ss 11.1	27-44-01-02
ETIM 7.0	EC002635

### Declarations of conformity

Low Voltage Directive	2014/35/EU (EN 60204-1:2018;EN 60529:1991)
-----------------------	--

Product description	<b>M12-A Female angled connector, Contacts: 4, 2.5-3.5 mm, unshielded, screw clamp, IP67</b>
-	-
Area	<b>M12-A series 713</b>
Part no.	<b>99 0430 324 04</b>

**Assembly instructions**

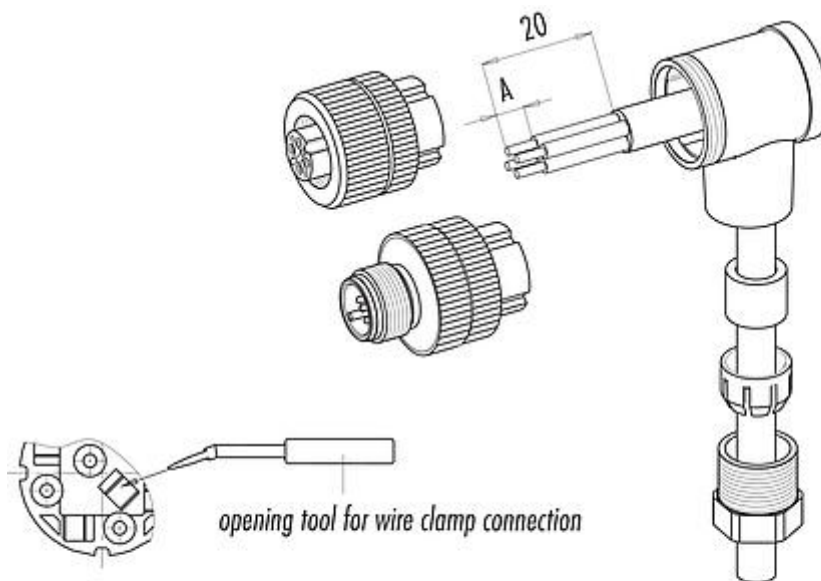

	<i>screw connection</i>	<i>solder version</i>	<i>wire clamp connection</i>
<i>measure A/mm</i>	<b>5</b>	<b>3,5</b>	<b>7</b>

*material of locking rings: plastic, zinc diecast, stainless steel*

Product description	M12-A Female angled connector, Contacts: 4, 2.5-3.5 mm, unshielded, screw clamp, IP67
-	-
Area	M12-A series 713
Part no.	99 0430 324 04

**Component part drawing**

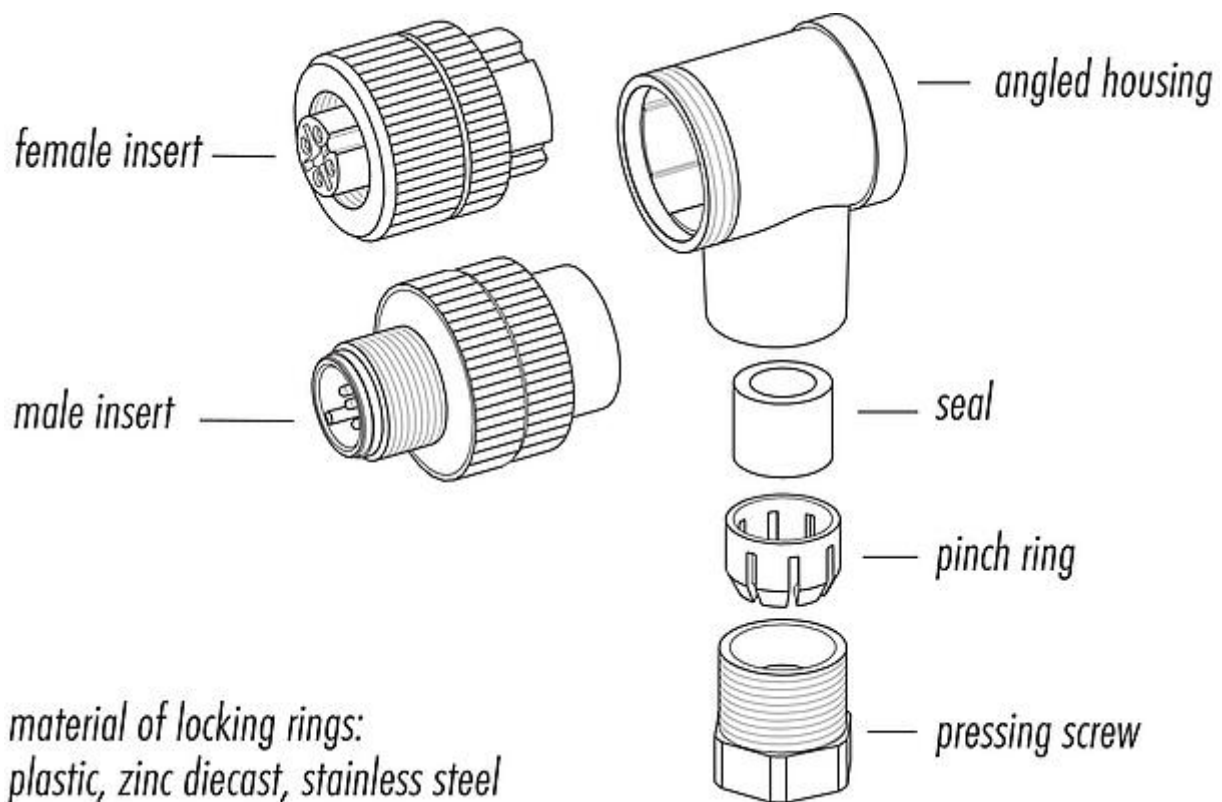

Product description	<b>M12-A Female angled connector, Contacts: 4, 2.5-3.5 mm, unshielded, screw clamp, IP67</b>
-	-
Area	<b>M12-A series 713</b>
Part no.	<b>99 0430 324 04</b>

### General Disclaim Notice

The connector must not be plugged or unplugged under load. Non-observance and improper use can result in personal injury.

The connectors have been developed for applications in plant engineering, control and electrical equipment construction. The user is responsible for checking whether the connectors can also be used in other areas of application.

To protect against unintentional opening of the connector, the thread between the housing and the connector head must be secured with a suitable cyanoacrylate adhesive when used in circuits with voltages dangerous to the touch. This does not apply to connectors used in SELV and PELV circuits according to IEC 61140 (EN 61140, VDE 0140-1).

Connectors which are used in circuits with voltages dangerous to the touch may only be installed and used by, or under the supervision of, persons with electrical engineering training, taking into account the applicable regulations and standards.

Plug connectors with enclosure protection IP67 and IP68 are not suitable for use under water. When used outdoors, the plug connectors must be protected separately against corrosion. For further information on the IP protection classes, please refer to the "Technical Information" download centre.

To lock the cable connector with the device connector, the threaded ring is tightened "hand-tight" (approx. 60 cNm).