

Product description	<b>M23 Female cable connector, Contacts: 19, 6.0-10.0 mm, shieldable, solder, IP67</b>
Area	<b>M23 series 623</b>
Part no.	<b>99 4644 00 19</b>

### Illustration

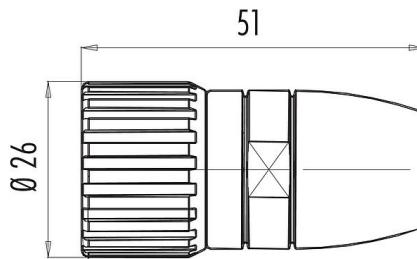

### Scale drawing



### Contact arrangement (Plug-in side)

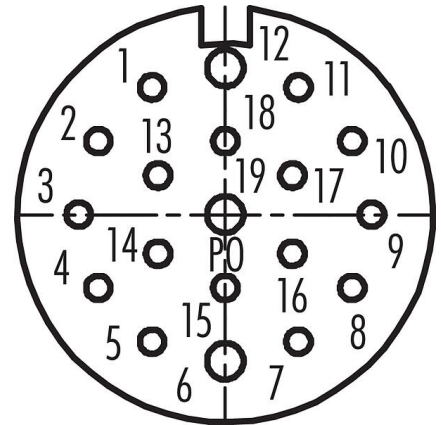

You can find the assembly instructions on the next page.

## Technical data

### General features

Part no.	<b>99 4644 00 19</b>
Connector design	Female cable connector
Version	Connector socket straight
Connector locking system	screw
Termination	solder
Degree of protection	IP67
Arrangement of contacts	clockwise
Cross-sectional area	16x1.00 / 3x1.50 mm <sup>2</sup> / 16 x AWG 18 / x AWG 16
Cable outlet	6.0-10.0 mm
Temperature range from/to	-25 °C / 125 °C
Mechanical operation	> 50 Mating cycles
Weight (g)	68.02
Customs tariff number	85369010

### Electrical parameters

Rated voltage	48 V
Rated impulse voltage	1500 V
Rated current (40 °C)	16x8 A / 3x10 A
Insulation resistance	≥ 10 <sup>10</sup> Ω
Pollution degree	3
Overvoltage category	II
Insulating material group	III
EMC compliance	shieldable
Shield connection	Grounding sleeve

# Product data sheet

## Power connectors



Product description	<b>M23 Female cable connector, Contacts: 19, 6.0-10.0 mm, shieldable, solder, IP67</b>
-	-
Area	<b>M23 series 623</b>
Part no.	<b>99 4644 00 19</b>

### Material

Contact body material	PBT/PA66
Contact material	CuSn (bronze)
Contact plating	Au (gold)
REACH SVHC	CAS 7439-92-1 (Lead)
SCIP number	2cdf2d73-ec5f-4a19-a87e-cd43403f1a9b

### Classifications

eCl@ss 11.1	27-44-01-02
ETIM 7.0	EC002635

### Assembly instructions

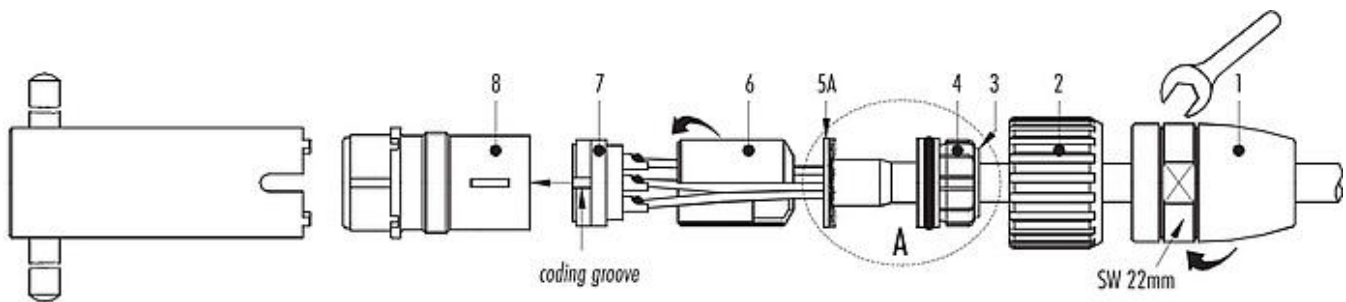

- Push the adapter (1), the coupling nut (2) and the sealing ring (4) with the gasket (3) onto the cable.
- Strip the cable coating by 23 mm.
- Detail A: Push back the shielding braid so it stands out at 90°. With a rotating motion, push the shielding braid (5A) over the foil or cotton braid and under the shielding braid. Cut the shielding braid and flush with the external diameter of the shielded sleeve (5A).
- Trim foil, filler and inner insulation.
- Strip the single wires by 3.5 mm, twist and tin.
- Solder the single wires to the contacts.
- Insert the distance shell (6).

- Guide the insert (7) and distance shell (6) into the insert sleeve (8), mind that the desired coding groove of the insert (7) is pushed into the coding bar.
- Press in the cable with the shield and sealing unit.
- Screw the adapter (1) as tight as possible.

Please note: torque for clamping screw for contact insert (7) with screw contacts:

- max. 0.1 Nm for screw contacts with mating dia. 1 mm
- max. 0.2 Nm for screw contacts with mating dia. 2 mm

Product description	<b>M23 Female cable connector, Contacts: 19, 6.0-10.0 mm, shieldable, solder, IP67</b>
-	-
Area	<b>M23 series 623</b>
Part no.	<b>99 4644 00 19</b>

### **General Disclaim Notice**

The connector must not be plugged or unplugged under load. Non-observance and improper use can result in personal injury.

The connectors have been developed for applications in plant engineering, control and electrical equipment construction. The user is responsible for checking whether the connectors can also be used in other areas of application.

Connectors which are used in circuits with voltages dangerous to the touch may only be installed and used by, or under the supervision of, persons with electrical engineering training, taking into account the applicable regulations and standards.

Plug connectors with enclosure protection IP67 and IP68 are not suitable for use under water. When used outdoors, the plug connectors must be protected separately against corrosion. For further information on the IP protection classes, please refer to the "Technical Information" download centre.

To lock the cable connector with the device connector, the threaded ring is tightened "hand-tight" (approx. 50 cNm).