

## Piston Valves



**The ultimate Technology  
for fluid control**

COMPANY  
WITH QUALITY SYSTEM  
CERTIFIED BY DNV  
=ISO 9001/2000=



European  
Community  
Conformity



Underwriters  
Laboratories  
Quality  
Certificate



*The ultimate Technology  
for fluid control*

**m&m** international

## means:

- Working with a staff of qualified professionals
- Enjoying the benefits of the most advanced technological research
- Quality at competitive price
- Warranty of a company conforming to the rigorous ISO 9001/2000 requirements
- Reliability of a 30-years experience on international markets
- To partner with a company belonging to a multinational group

### GENERAL INDEX

Product index	Page 01
M&M Piston Valves: features and benefits	Page 03
Seal kit	Pages 32 ÷ 35
Technical information	Pages 36 ÷ 37
Valves selection chart	Pages 38 ÷ 43
Opening speed chart	Page 44
Declaration of conformity to CE	Page 44
Coding chart	Page 45

## PRODUCT INDEX

	TYPE	Actuator	Function	Code	Page
	<b>BLG</b> FULLY BRASS	Ø 32	Normally closed	BLG204DVW00 / BLG205DVW00	4
	TYPE	Actuator	Function	Code	Page
	<b>COMPACT 45</b> BRONZE BODY / BRASS BONNET	Ø 45	Normally closed	CG205CTW00 ÷ CG207CTY00	5
			Normally open	RCG205CTW00 ÷ RCG207CTY00	
			Bidirectional NC	BCG205CTW00 ÷ BCG207CTY00	
			Double acting	DCG205CTW00 ÷ DCG207CTY00	
	TYPE	Actuator	Function	Code	Page
	<b>REGULAR</b> BRONZE BODY / BRASS BONNET	Ø 63 / 90	Normally closed	CG205STW00 ÷ CG210STJ00 CG207LTY00 ÷ CG210LTJ00	6
			Normally open	RCG205STW00 ÷ RCG210STJ00 RCG207LTY00 ÷ RCG210LTJ00	7
			Bidirectional NC	BCG205STW00 ÷ BCG210STJ00 BCG207LTY00 ÷ BCG210LTJ00	8
			Double acting	DCG205STW00 ÷ DCG210STJ00	9
	TYPE	Connection	Flow direction	Code	Page
	<b>CG - MANUAL</b> BRONZE BODY / BRASS BONNET	1/2" ÷ 2"	Over / under seat	CG2050TW00 ÷ CG2100TJ00	10
	TYPE	Actuator	Function	Code	Page
	<b>COMPACT 45</b> STAINLESS STEEL	Ø 45	Normally closed	PG205CTW00 ÷ PG207CTY00	11
			Normally open	RPG205CTW00 ÷ RPG207CTY00	
			Bidirectional NC	BPG205CTW00 ÷ BPG207CTY00	
			Double acting	DPG205CTW00 ÷ DPG207CTY00	
	TYPE	Actuator	Function	Code	Page
	<b>REGULAR</b> STAINLESS STEEL	Ø 63 / 90	Normally closed	PG205STW00 ÷ PG210STJ00 PG207LTY00 ÷ PG210LTJ00	12
			Normally open	RPG205STW00 ÷ RPG210STJ00 RPG207LTY00 ÷ RPG210LTJ00	13
			Bidirectional NC	BPG205STW00 ÷ BPG210STJ00 BPG207LTY00 ÷ BPG210LTJ00	14
			Double acting	DPG205STW00 ÷ DPG210STJ00	15
	TYPE	Connection	Flow direction	Code	Page
	<b>PG - MANUAL</b> STAINLESS STEEL	1/2" ÷ 2"	Over / under seat	PG2050TW00 ÷ PG2100TJ00	16
	TYPE	Actuator	Types of connection	Code	Page
	<b>STAINLESS STEEL TYPES WITH WELDING CONNECTION</b>	Ø 45 / 63 / 90	Socket weld	PS205.... ÷ PS210....	17
			Butt weld for DIN 11850 pipe	PW205.... ÷ PW210....	
			Butt weld for ISO 65 pipe	PB205.... ÷ PB210....	
			Butt weld for ISO 4200 pipe	PH205.... ÷ PH210....	

## PRODUCT INDEX

	TYPE	Actuator	Function	Code	Page	
	<b>REGULAR WITH FLANGED CONNECTION - BS 4504</b>	Ø 63 / 90		Normally closed	PD205STW00 ÷ PD210STJ00 PD207LTY00 ÷ PD210LTJ00	18
				Normally open	RPD205STW00 ÷ RPD210STJ00 RPD207LTY00 ÷ RPD210LTJ00	
				Bidirectional NC	BPD205STW00 ÷ BPD210STJ00 BPD207LTY00 ÷ BPD210LTJ00	
<b>REGULAR WITH FLANGED CONNECTION - ANSI B16.5</b>	Ø 63 / 90		Normally closed	PA205STW00 ÷ PA210STJ00 PA207LTY00 ÷ PA210LTJ00	18	
			Normally open	RPA205STW00 ÷ RPA210STJ00 RPA207LTY00 ÷ RPA210LTJ00		
			Bidirectional NC	BPA205STW00 ÷ BPA210STJ00 BPA207LTY00 ÷ BPA210LTJ00		

	TYPE	Actuator	Function	Code	Page	
	<b>COMPACT 45 WITH CLAMP-END ISO 2852</b>	Ø 45		Normally closed	PC205CTW00 ÷ PC206CTX00	19
				Normally open	RPC205CTW00 ÷ RPC206CTX00	
				Bidirectional NC	BPC205CTW00 ÷ BPC206CTX00	
<b>COMPACT 45 WITH CLAMP-END ASME BPE</b>	Ø 45		Normally closed	PP205CTW00 ÷ PP206CTX00	19	
			in Ruhstellung geöffnet	RPP205CTW00 ÷ RPP206CTX00		
			Bidirectional NC	BPP205CTW00 ÷ BPP206CTX00		

	TYPE	Actuator	Function	Code	Page	
	<b>REGULAR WITH CLAMP-END ISO 2852</b>	Ø 63 / 90		Normally closed	PC205STW00 ÷ PC210STJ00 PC207LTY00 ÷ PC210LTJ00	19
				Normally open	RPC205STW00 ÷ RPC210STJ00 RPC207LTY00 ÷ RPC210LTJ00	
				Bidirectional NC	BPC205STW00 ÷ BPC210STJ00 BPC207LTY00 ÷ BPC210LTJ00	
	<b>REGULAR WITH CLAMP-END ASME BPE</b>	Ø 63 / 90		Normally closed	PP205STW00 ÷ PP207STY00 PP209STK00 / PP210STJ00 PP207LTY00 / PP209LTK00 / PP210LTJ00	19
				Normally open	RPP205STW00 ÷ RPP207STY00 RPP209STK00 / RPP210STJ00 RPP207LTY00 / RPP209LTK00 / RPP210LTJ00	
Bidirectional NC				BPP205STW00 ÷ BPP207STY00 BPP209STK00 / BPP210STJ00 BPP207LTY00 / BPP209LTK00 / BPP210LTJ00		

	TYPE	Actuator	Function	Code	Page	
	<b>REGULAR - HIGH TEMPERATURE VERSION</b>	Ø 63 / 90		Normally closed	PG205STW0H ÷ PG207STY0H PG208LTZ0H ÷ PG210LTJ0H	22
				Bidirectional NC	BPG205STW0H ÷ BPG207STY0H BPG208LTZ0H ÷ BPG210LTJ0H	23

	S.S. PAV SERIES M AND G ATEX II 2 GD c TX		
	Actuator	Function	Page
	Ø 63 / 90	Normally closed Normally open Bidirectional NC	24

	S.S. CONTROL PAV WITH INTEGRATED POSITIONER		
	Actuator	Function	Page
	Ø 63 / 90	Normally closed Normally open	25 26 27

### OPTIONS



**STROKE REGULATOR**  
Page 28



**TRAVEL REGULATOR**  
Page 28



**MANUAL OVERRIDE**  
Page 28



**TRAVEL SWITCH KIT**  
Page 28



**SWITCH TYPE "A"**  
Page 29



**SWITCH TYPE "B"**  
Page 29



**B356/B326 D326**  
Page 30



**N326CVEK (ATEX)**  
Page 31

## M&M INTERNATIONAL PISTON VALVES

Scheme of an M&M International piston valve components:

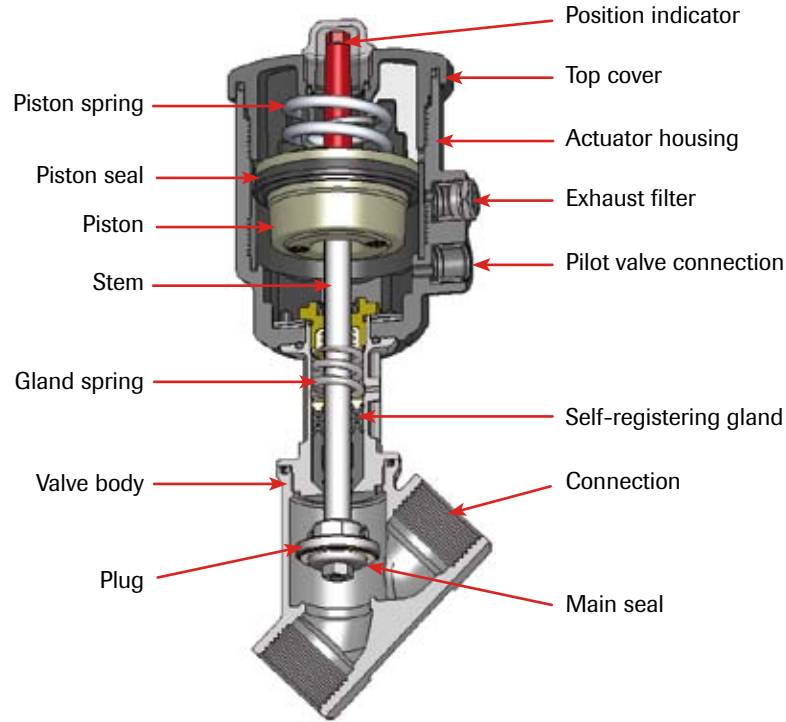

### Benefits of M&M International Piston Valves

- Standard versions with high performing components** ➔ **Covering a wide range of industrial applications with reduced stock**
- Standard seal materials as FKM and PTFE** ➔ **Max. compatibility with fluids resistance at high temperatures**
- Bidirectional version** ➔ **Waterhammer-free installation**
- Wide choice of connections** ➔ **Thread, welding, flange, clamp**
- Actuator orientability at 360°** ➔ **Easy and quick installation**
- Red position indicator** ➔ **Immediate visibility of the valve position**
- Self-registering gland and chevron packing** ➔ **Smooth stem movement for longer durability**
- Housing with angle seat design** ➔ **High flow rate, low pressure drop**
- S.S. valves with universal design** ➔ **Suitable for vacuum applications**
- Universal mounting M&M solenoid pilot valves** ➔ **Max. flexibility during installation**
- Actuator with built-in exhaust filter** ➔ **Higher reliability**



## 2/2 WAY COMPACT PISTON VALVE G 3/8" ÷ 1/2" – BRASS

Piston valve with external pneumatic actuation, compact and solid construction. Suitable for neutral media with particles in suspension, a situation where a standard servoassisted solenoid valve may get clogged.

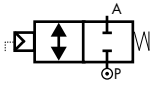

normally closed  
flow over / under seat

### TECHNICAL SPECIFICATIONS

- Media: water and inert fluids, air and inert gases
- Media temperature: -10°C ÷ +90°C
- Ambient temperature: -10°C ÷ +80°C
- Pilot media: filtered air
- Actuator body material: brass (CW617N EN 12165)
- Body material: brass (CW617N EN 12165)
- Stem material: AISI 316L
- Seal material: FKM
- Frequency: 6 cycles per minute

### BENEFITS

- Waterhammer-free design (flow direction 2→1)
- To be fitted with banjo bolt pilot solenoid valve (B356CVCMK)
- Design for vacuum applications up to 10<sup>-2</sup> mbar

### OPTIONS

- NPT connection (e.g. Code BLN205DVW00)
- Electroless nickel plating treatment (e.g. Code BLG205DVW0K)
- NBR seal (e.g. Code BLG205DBW00)

### TYPE: BLG



### SELECTION TABLE

VALVE	Body connection	DN	Flow rate Kvs	Working pressure		Flow direction	Pilot pressure		Actuator Ø
				min	max		min	max	
Code	[ISO 228 G]	[mm]	[l/min]	[barg]	[barg]	-	[barg]	[barg]	[mm]
BLG204DVW00	3/8"	13.5	56 / 45	0	10	1→2 / 2→1	4.5	10	32
BLG205DVW00	1/2"	13.5	70 / 55	0	10	1→2 / 2→1	4.5	10	32

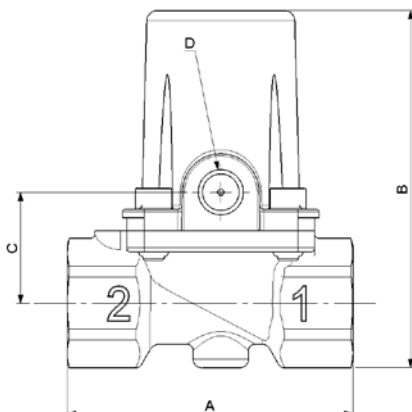

### DIMENSIONS & WEIGHTS

Body connection	A	B	C	D	Weight
[ISO 228 G]	[mm]	[mm]	[mm]	[ISO 228 G]	[kg]
3/8"	67	84	26	1/8"	0.55
1/2"	67	84	26	1/8"	0.52

## 2/2 WAY PISTON VALVE G 1/2" ÷ 1" – BRONZE

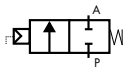

**NC normally closed  
over seat flow**

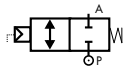

**NC normally closed  
Bidirectional**

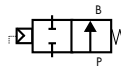

**NO normally open  
under seat flow**

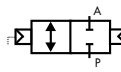

**Double acting  
Bidirectional**

### TECHNICAL SPECIFICATIONS

- Media: water, oil, air, aggressive media and steam ①
- Media temperature: -10°C ÷ +180°C
- Ambient temperature: -10°C ÷ +60°C
- Pilot media: air, inert gases, water
- Body material: bronze (CB491K EN 1982)
- Bonnet material: brass (CW617N EN 12165)
- Actuator body material: Polyamide PA6 (reinforced fiberglass 30%)
- Seal material: PTFE type TFM 1600
- Position indicator as standard

### BENEFITS

- Waterhammer-free design for BCG - DCG type (2→1)
- Actuator housing rotation 360°
- Design suitable for vacuum applications up to 10<sup>-2</sup> mbar

### OPTIONS

- NPT connection (e.g. Code CN205CTW00)

### TYPE: COMPACT 45



### SELECTION TABLE

VALVE	Connection	DN	Flow rate Kvs	Working pressure ①		Flow direction	Pilot pressure ②		Function
				min	max		min	max	
Code	[ISO 228 G]	[mm]	[l/min]	[barg]	[barg]	-	[barg]	[barg]	-
CG205CTW00	1/2"	15	75	0	16	1→2	3.8	10	Normally closed
CG206CTX00	3/4"	20	133	0	16	1→2	5.8	10	
CG207CTY00	1"	25	208	0	16	1→2	6.5	10	
BCG205CTW00	1/2"	15	75	0	16 / 16	1→2 / 2→1	6.2 / 5	10	Normally closed
BCG206CTX00	3/4"	20	133	0	16 / 7	1→2 / 2→1	8.7 / 5	10	
BCG207CTY00	1"	25	208	0	16 / 5	1→2 / 2→1	9.5 / 5	10	
RCG205CTW00	1/2"	15	75	0	16	2→1	4	10	Normally open
RCG206CTX00	3/4"	20	133	0	16	2→1	6.2	10	
RCG207CTY00	1"	25	208	0	16	2→1	8.8	10	
DCG205CTW00	1/2"	15	75	0	16 / 16	1→2 / 2→1	3	10	Double acting
DCG206CTX00	3/4"	20	133	0	16 / 16	1→2 / 2→1	5	10	
DCG207CTY00	1"	25	208	0	16 / 16	1→2 / 2→1	8.5	10	

① Steam: Max. working pressure 10 bar (9 barg); ② Minimum pilot pressure at max. working pressure; for lower working pressure see selection charts

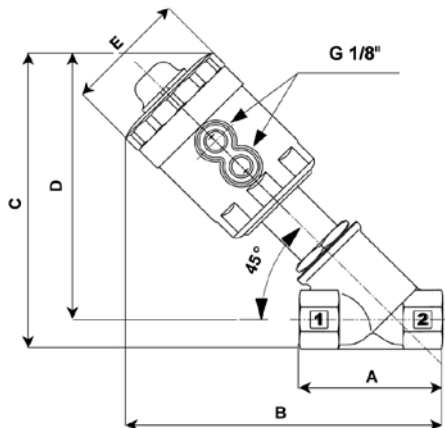

### DIMENSIONS & WEIGHTS

Connection	Actuator Ø	A	B	C	D	E	Weight
[ISO 228 G]	[mm]	[mm]	[mm]	[mm]	[mm]	[mm]	[kg]
1/2"	45	65	144	136	123	57	0.8
3/4"	45	75	149	142	126	57	0.9
1"	45	90	168	161	141	57	1.1

## 2/2 WAY PISTON VALVE G 1/2" ÷ 2" – BRONZE

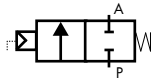

normally closed  
flow over seat

### TECHNICAL SPECIFICATIONS

Media: water, oil, air, aggressive media and steam ❶  
 Media temperature: -10°C ÷ +180°C  
 Ambient temperature: -10°C ÷ +60°C  
 Pilot media: air, inert gases, water  
 Body material: bronze (CB491K EN 1982)  
 Bonnet material: brass (CW617N EN 12165)  
 Actuator body material: Polyamide PA6 (reinforced fiberglass 30%)  
 Seal material: PTFE type TFM 1600  
 Position indicator as standard

### BENEFITS

Actuator housing rotation 360°

### OPTIONS

Manual override (e.g. Code CG205STWM0) see page 28  
 Stroke regulator (e.g. Code CG210STJR0) see page 28  
 Travel switch (e.g. Code CG208LTZ0) see page 28  
 Design for vacuum applications up to 10<sup>-2</sup> mbar (e.g. Code CG205STW0V)  
 NPT connection (e.g. Code CN205STW00)

### TYPE: REGULAR NC



### SELECTION TABLE

VALVE	Connection	DN	Flow rate Kvs	Working pressure ❶		Flow direction	Pilot pressure ❷		Actuator Ø
				min	max		min	max	
Code	[ISO 228 G]	[mm]	[l/min]	[barg]	[barg]	[1 → 2]	[barg]	[barg]	[mm]
CG205STW00	1/2"	15	87	0	20	over seat	3.7	10	63
CG206STX00	3/4"	20	164	0	20	over seat	4.4	10	
CG207STY00	1"	25	260	0	20	over seat	5	10	
CG208STZ00	1 1/4"	32	410	0	16	over seat	5.9	10	
CG209STK00	1 1/2"	40	700	0	16	over seat	9	10	
CG210STJ00	2"	50	950	0	11	over seat	8	10	
CG207LTY00	1"	25	260	0	20	over seat	2	8	90
CG208LTZ00	1 1/4"	32	410	0	16	over seat	3.5	8	
CG209LTK00	1 1/2"	40	700	0	16	over seat	4	8	
CG210LTJ00	2"	50	950	0	15	over seat	6.5	8	

❶ Steam: Max. working pressure 10 bar (9 barg); ❷ Minimum pilot pressure at max. working pressure; for lower working pressure see selection charts

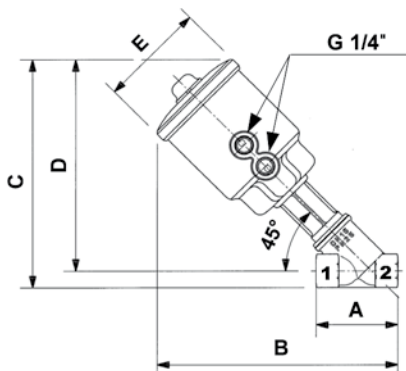

### DIMENSIONS & WEIGHTS

Connection	Actuator Ø	A	B	C	D	E	Weight
[ISO 228 G]	[mm]	[mm]	[mm]	[mm]	[mm]	[mm]	[kg]
1/2"	63	65	192	184	171	85	1.2
3/4"	63	75	198	192	176	85	1.3
1"	63	90	212	205	185	85	1.5
1 1/4"	63	110	225	217	193	85	1.9
1 1/2"	63	120	230	225	198	85	2.1
2"	63	150	248	241	207	85	2.9
1"	90	90	223	216	196	112	2.0
1 1/4"	90	110	234	227	202	112	2.4
1 1/2"	90	120	239	235	207	112	2.6
2"	90	150	257	250	216	112	3.3



## 2/2 WAY PISTON VALVE G 1/2" ÷ 2" NORMALLY OPEN – BRONZE

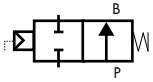

normally open  
flow under seat

### TECHNICAL SPECIFICATIONS

Media: water, oil, air, aggressive media and steam ❶  
 Media temperature: -10°C ÷ +180°C  
 Ambient temperature: -10°C ÷ +60°C  
 Pilot media: air, inert gases, water  
 Body material: bronze (CB491K EN 1982)  
 Bonnet material: brass (CW617N EN 12165)  
 Actuator body material: Polyamide PA6 (reinforced fiberglass 30%)  
 Seal material: PTFE type TFM 1600  
 Position indicator as standard

### BENEFITS

Waterhammer-free design  
 Actuator housing rotation 360°

### OPTIONS

Manual override (e.g. Code CG205STWM0) see page 28  
 Stroke regulator (e.g. Code CG210STJR0) see page 28  
 Travel switch (e.g. Code CG208LTZ0) see page 28  
 Design for vacuum applications up to 10<sup>-2</sup> mbar (e.g. Code CG205STW0V)  
 NPT Connection (e.g. Code CN205STW00)

### TYPE: REGULAR NO



### SELECTION TABLE

VALVE	Connection	DN	Flow rate Kvs	Working pressure ❶		Flow direction	Pilot pressure ❷		Actuator Ø
				min	max		min	max	
Code	[ISO 228 G]	[mm]	[l/min]	[barg]	[barg]	[2 → 1]	[barg]	[barg]	[mm]
RCG205STW00	1/2"	15	87	0	16	under seat	2.5	10	63
RCG206STX00	3/4"	20	164	0	16	under seat	4.3	10	
RCG207STY00	1"	25	260	0	16	under seat	5.5	10	
RCG208STZ00	1 1/4"	32	410	0	16	under seat	6.5	10	
RCG209STK00	1 1/2"	40	700	0	16	under seat	9	10	
RCG210STJ00	2"	50	950	0	12	under seat	9.4	10	
RCG207LTY00	1"	25	260	0	16	under seat	2	8	90
RCG208LTZ00	1 1/4"	32	410	0	16	under seat	4	8	
RCG209LTK00	1 1/2"	40	700	0	16	under seat	5	8	
RCG210LTJ00	2"	50	950	0	16	under seat	7	8	

❶ Steam: Max. working pressure 10 bar (9 barg); ❷ Minimum pilot pressure at max. working pressure; for lower working pressure see selection charts

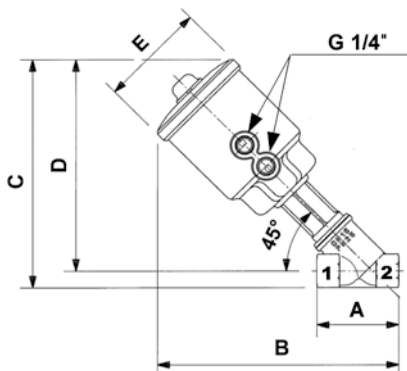

### DIMENSIONS & WEIGHTS

Connection	Actuator Ø	A	B	C	D	E	Weight
[ISO 228 G]	[mm]	[mm]	[mm]	[mm]	[mm]	[mm]	[kg]
1/2"	63	65	192	184	171	85	1.2
3/4"	63	75	198	192	176	85	1.3
1"	63	90	212	205	185	85	1.5
1 1/4"	63	110	225	217	193	85	1.9
1 1/2"	63	120	230	225	198	85	2.1
2"	63	150	248	241	207	85	2.9
1"	90	90	223	216	196	112	2.0
1 1/4"	90	110	234	227	202	112	2.4
1 1/2"	90	120	239	235	207	112	2.6
2"	90	150	257	250	216	112	3.3

## 2/2 WAY PISTON VALVE G 1/2" ÷ 2" BIDIRECTIONAL – BRONZE

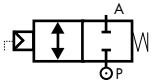

normally closed  
flow over / under seat

### TECHNICAL SPECIFICATIONS

Media: water, oil, air, aggressive media and steam ❶  
 Media temperature: -10°C ÷ +180°C  
 Ambient temperature: -10°C ÷ +60°C  
 Pilot media: air, inert gases, water  
 Body material: bronze (CB491K EN 1982)  
 Bonnet material: brass (CW617N EN 12165)  
 Actuator body material: Polyamide PA6 (reinforced fiberglass 30%)  
 Seal material: PTFE type TFM 1600  
 Position indicator as standard

### BENEFITS

Waterhammer-free design (with flow direction 2→1)  
 Actuator housing rotation 360°

### OPTIONS

Manual override (e.g. Code BCG205STWM0) see page 28  
 Stroke regulator (e.g. Code BCG210STJR0) see page 28  
 Travel switch (e.g. Code BCG208LTZ10) see page 28  
 Design for vacuum applications up to 10<sup>-2</sup> mbar (e.g. Code BCG205STW0V)  
 NPT Connection (e.g. Code BCN205STW00)

### TYPE: REGULAR BD



### SELECTION TABLE

VALVE	Connection	DN	Flow rate Kvs	Working pressure ❶		Flow direction	Pilot pressure ❷		Actuator Ø
				min	max		min	max	
Code	[ISO 228 G]	[mm]	[l/min]	[barg]	[barg]	-	[barg]	[barg]	[mm]
BCG205STW00	1/2"	15	87	0	16	1→2 / 2→1	5.5 / 3.8	10	63
BCG206STX00	3/4"	20	164	0	16	1→2 / 2→1	6 / 3.8	10	
BCG207STY00	1"	25	260	0	16 / 11	1→2 / 2→1	6.5 / 3.8	10	
BCG208STZ00	1 1/4"	32	410	0	16 / 6	1→2 / 2→1	6.8 / 3.8	10	
BCG209STK00	1 1/2"	40	700	0	12 / 4	1→2 / 2→1	9 / 3.8	10	
BCG210STJ00	2"	50	950	0	8 / 2.5	1→2 / 2→1	9 / 3.8	10	
BCG207LTY00	1"	25	260	0	16 / 14	1→2 / 2→1	4 / 3.3	8	90
BCG208LTZ00	1 1/4"	32	410	0	16 / 12	1→2 / 2→1	5 / 3.3	8	
BCG209LTK00	1 1/2"	40	700	0	16 / 8	1→2 / 2→1	6 / 3.3	8	
BCG210LTJ00	2"	50	950	0	14 / 6	1→2 / 2→1	8 / 3.3	8	

❶ Steam: Max. working pressure 10 bar (9 barg); ❷ Minimum pilot pressure at max. working pressure; for lower working pressure see selection charts

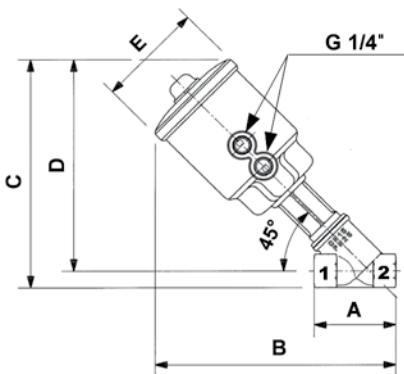

### DIMENSIONS & WEIGHTS

Connection	Actuator Ø	A	B	C	D	E	Weight
[ISO 228 G]	[mm]	[mm]	[mm]	[mm]	[mm]	[mm]	[kg]
1/2"	63	65	192	184	171	85	1.2
3/4"	63	75	198	192	176	85	1.3
1"	63	90	212	205	185	85	1.5
1 1/4"	63	110	225	217	193	85	1.9
1 1/2"	63	120	230	225	198	85	2.1
2"	63	150	248	241	207	85	2.9
1"	90	90	223	216	196	112	2.0
1 1/4"	90	110	234	227	202	112	2.4
1 1/2"	90	120	239	235	207	112	2.6
2"	90	150	257	250	216	112	3.3

## 2/2 WAY PISTON VALVE G 1/2" ÷ 2" DOUBLE ACTING – BRONZE

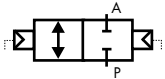

double acting  
flow over / under seat

### TECHNICAL SPECIFICATIONS

Media: water, oil, air, aggressive media and steam ❶  
 Media temperature: -10°C ÷ +180°C  
 Ambient temperature: -10°C ÷ +60°C  
 Pilot media: air, inert gases, water  
 Body material: bronze (CB491K EN 1982)  
 Bonnet material: brass (CW617N EN 12165)  
 Actuator body material: Polyamide PA6 (reinforced fiberglass 30%)  
 Seal material: PTFE type TFM 1600  
 Position indicator as standard

### BENEFITS

Waterhammer-free design (with flow direction 2→1)  
 Actuator housing rotation 360°

### OPTIONS

Manual override (e.g. Code DCG205STWM0) see page 28  
 Stroke regulator (e.g. Code DCG210STJR0) see page 28  
 Travel switch (e.g. Code DCG208LTZ10) see page 28  
 Design for vacuum applications up to 10<sup>-2</sup> mbar (e.g. Code DCG205STW0V)  
 NPT Connection (e.g. Code DCN205STW00)

### TYPE: REGULAR DA



### SELECTION TABLE

VALVE	Connection	DN	Flow rate Kvs	Working pressure ❶		Flow direction	Pilot pressure ❷		Actuator Ø
				min	max		min	max	
Code	[ISO 228 G]	[mm]	[l/min]	[barg]	[barg]	-	min [barg]	max [barg]	[mm]
DCG205STW00	1/2"	15	87	0	16	1 ↔ 2	1.8	2	63
DCG206STX00	3/4"	20	164	0	16	1 ↔ 2	2	3.8	
DCG207STY00	1"	25	260	0	16	1 ↔ 2	3	5	
DCG208STZ00	1 1/4"	32	410	0	16	1 ↔ 2	4.5	6	
DCG209STK00	1 1/2"	40	700	0	16	1 ↔ 2	6.5	7	
DCG210STJ00	2"	50	950	0	12	1 ↔ 2	9	10	

❶ Steam: Max. working pressure 10 bar (9 barg); ❷ Minimum pilot pressure at max. working pressure; for lower working pressure see selection charts

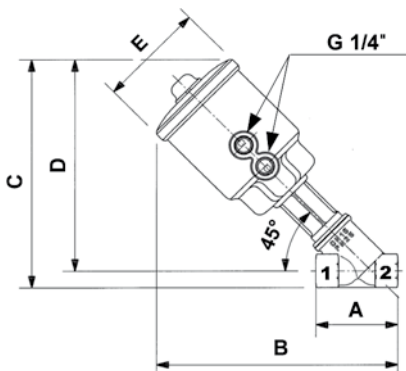

### DIMENSIONS & WEIGHTS

Connection	Actuator Ø	A	B	C	D	E	Weight
[ISO 228 G]	[mm]	[mm]	[mm]	[mm]	[mm]	[mm]	[kg]
1/2"	63	65	192	184	171	85	1.2
3/4"	63	75	198	192	176	85	1.3
1"	63	90	212	205	185	85	1.5
1 1/4"	63	110	225	217	193	85	1.9
1 1/2"	63	120	230	225	198	85	2.1
2"	63	150	248	241	207	85	2.9

## MANUAL ANGLE SEAT VALVE G 1/2" ÷ 2" – BRONZE

flow over/ under seat

### TECHNICAL SPECIFICATIONS

Media: water, oil, air, aggressive media and steam ❶

Media temperature: -10°C ÷ +180°C

Ambient temperature: -10°C ÷ +60°C

Body material: bronze (CB491K EN 1982)

Bonnet material: brass (CW617N EN 12165)

Seal material: PTFE type TFM 1600

### OPTIONS

NPT Connection (e.g. Code CN2050TW00)

### TYPE: CG MANUAL



### SELECTION TABLE

VALVE	Connection	DN	Flow rate Kvs	Working pressure ❶		Flow direction
				min	max	
Code	[ISO 228 G]	[mm]	[l/min]	[barg]	[barg]	-
CG2050TW00	1/2"	15	87	0	25	1 ↔ 2
CG2060TX00	3/4"	20	164	0	25	1 ↔ 2
CG2070TY00	1"	25	260	0	25	1 ↔ 2
CG2080TZ00	1 1/4"	32	410	0	25	1 ↔ 2
CG2090TK00	1 1/2"	40	700	0	25	1 ↔ 2
CG2100TJ00	2"	50	916	0	16	1 ↔ 2

❶ Steam: Max. working pressure 10 bar (9 barg);

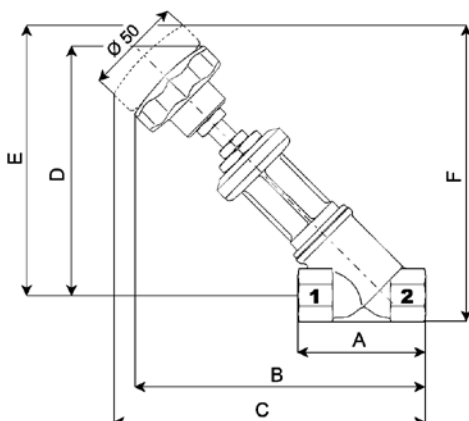

### DIMENSIONS & WEIGHTS

Connection	A	B	C	D	E	F	Weight
[ISO 228 G]	[mm]	[mm]	[mm]	[mm]	[mm]	[mm]	[kg]
1/2"	65	142	150	121	128	141	0.75
3/4"	75	148	155	126	133	150	0.80
1"	90	163	172	135	145	165	1.20
1 1/4"	110	175	188	143	156	181	1.80
1 1/2"	120	180	193	148	161	189	2.10
2"	150	198	212	157	170	205	3.10

## 2/2 WAY PISTON VALVE G 1/2" ÷ 3/4" – STAINLESS STEEL

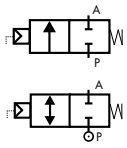

**NC normally closed over seat flow**

**NC normally closed Bidirectional**

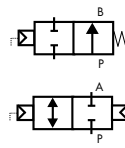

**NO normally open under seat flow**

**Double acting Bidirectional**

### TECHNICAL SPECIFICATIONS

- Media: water, oil, air, aggressive media and steam ①
- Media temperature: -10°C ÷ +180°C
- Ambient temperature: -10°C ÷ +60°C
- Pilot media: air, inert gases, water
- Body material: AISI 316L (see page 37)
- Bonnet material: AISI 316L (see page 37)
- Actuator body material: Polyamide PA6 (reinforced fiberglass 30%)
- Seal material: PTFE type TFM 1600
- Position indicator as standard

### BENEFITS

- Waterhammer-free design for BPG - DPG type (2→1)
- Actuator housing rotation 360°
- Design suitable for vacuum applications up to 10<sup>-2</sup> mbar

### OPTIONS

- NPT Connection (e.g. Code PN205CTW00)
- Weld ends see page 17

### TYPE: COMPACT 45



### SELECTION TABLE

VALVE	Connection	DN	Flow rate Kvs	Working pressure ①		Flow direction	Pilot pressure ②		Function
				min	max		min	max	
Code	[ISO 228 G]	[mm]	[l/min]	[barg]	[barg]	-	[barg]	[barg]	-
PG205CTW00	1/2"	15	75	0	16	1→2	3.8	10	normally closed
PG206CTX00	3/4"	20	133	0	16	1→2	5.8	10	
BPG205CTW00	1/2"	15	75	0	16 / 16	1→2 / 2→1	6.2 / 5	10	normally closed
BPG206CTX00	3/4"	20	133	0	16 / 7	1→2 / 2→1	8.7 / 5	10	
RPG205CTW00	1/2"	15	75	0	16	2→1	4	10	normally open
RPG206CTX00	3/4"	20	133	0	16	2→1	6.2	10	
DPG205CTW00	1/2"	15	75	0	16 / 16	1→2 / 2→1	3	10	double acting
DPG206CTX00	3/4"	20	133	0	16 / 16	1→2 / 2→1	5	10	

① Steam: Max. working pressure 10 bar (9 barg); ② Minimum pilot pressure at max. working pressure; for lower working pressure see selection charts

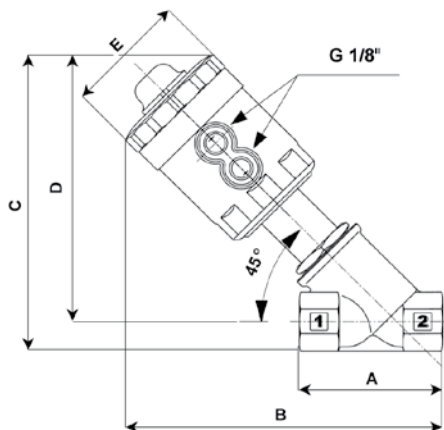

### DIMENSIONS & WEIGHTS

Connection	Actuator Ø	A	B	C	D	E	Weight
[ISO 228 G]	[mm]	[mm]	[mm]	[mm]	[mm]	[mm]	[kg]
1/2"	45	65	144	136	123	57	0.8
3/4"	45	75	149	142	126	57	0.9



## 2/2 WAY PISTON VALVE G 1/2" ÷ 2" – STAINLESS STEEL

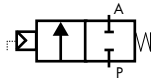

normally closed  
flow over seat

### TECHNICAL SPECIFICATIONS

Media: water, oil, air, aggressive media and steam <sup>①</sup>  
 Media temperature: -10°C ÷ +180°C  
 Ambient temperature: -10°C ÷ +60°C  
 Pilot media: air, inert gases, water  
 Body material: AISI 316L (see page 37)  
 Bonnet material: AISI 316L (see page 37)  
 Actuator body material: Polyamide PA6 (reinforced fiberglass 30%)  
 Seal material: PTFE type TFM 1600  
 Position indicator as standard  
 Valves DN32-DN50 complying with 97/23 Directive Category I

### BENEFITS

Actuator housing rotation 360°  
 Design suitable for vacuum applications up to 10<sup>-2</sup> mbar

### OPTIONS

Manual override (e.g. Code PG205STWM0) see page 28  
 Stroke regulator (e.g. Code PG210STJR0) see page 28  
 Travel switch (e.g. Code PG208LTZ|0) see page 28  
 NPT Connection (e.g. Code PN205STW00)  
 Weld ends see page 17

### TYPE: REGULAR NC



### SELECTION TABLE

VALVE	Connection	DN	Flow rate Kvs	Working pressure <sup>①</sup>		Flow direction	Pilot pressure <sup>②</sup>		Actuator Ø
				min	max		min	max	
Code	[ISO 228 G]	[mm]	[l/min]	[barg]	[barg]	[1 → 2]	[barg]	[barg]	[mm]
PG205STW00	1/2"	15	87	0	20	over seat	3.7	10	63
PG206STX00	3/4"	20	164	0	20	over seat	4.4	10	
PG207STY00	1"	25	260	0	20	over seat	5	10	
PG208STZ00	1 1/4"	32	410	0	16	over seat	5.9	10	
PG209STK00	1 1/2"	40	700	0	16	over seat	9	10	
PG210STJ00	2"	50	950	0	11	over seat	8	10	
PG207LTY00	1"	25	260	0	20	over seat	2	8	90
PG208LTZ00	1 1/4"	32	410	0	16	over seat	3.5	8	
PG209LTK00	1 1/2"	40	700	0	16	over seat	4	8	
PG210LTJ00	2"	50	950	0	15	over seat	6.5	8	

<sup>①</sup> Steam: Max. working pressure 10 bar (9 barg); <sup>②</sup> Minimum pilot pressure at max. working pressure; for lower working pressure see selection charts

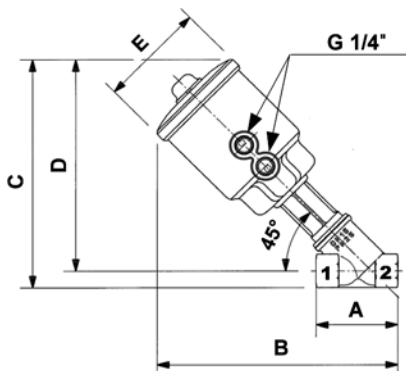

### DIMENSIONS & WEIGHTS

Connection	Actuator Ø	A	B	C	D	E	Weight
[ISO 228 G]	[mm]	[mm]	[mm]	[mm]	[mm]	[mm]	[kg]
1/2"	63	65	192	184	171	85	1.2
3/4"	63	75	198	192	176	85	1.3
1"	63	90	212	205	185	85	1.5
1 1/4"	63	110	225	217	193	85	1.9
1 1/2"	63	120	230	225	198	85	2.1
2"	63	150	248	241	207	85	2.9
1"	90	90	223	216	196	112	2.0
1 1/4"	90	110	234	227	202	112	2.4
1 1/2"	90	120	239	235	207	112	2.6
2"	90	150	257	250	216	112	3.3

## 2/2 WAY PISTON VALVE G 1/2" ÷ 2" NORMALLY OPEN – STAINLESS STEEL

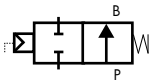

normally open  
flow under seat

### TECHNICAL SPECIFICATIONS

- Media: water, oil, air, aggressive media and steam ①
- Media temperature: -10°C ÷ +180°C
- Ambient temperature: -10°C ÷ +60°C
- Pilot media: air, inert gases, water
- Body material: AISI 316L (see page 37)
- Bonnet material: AISI 316L (see page 37)
- Actuator body material: Polyamide PA6 (reinforced fiberglass 30%)
- Seal material: PTFE type TFM 1600
- Position indicator as standard
- Valves DN32-DN50 complying with 97/23 Directive Category I

### BENEFITS

- Waterhammer-free design
- Actuator housing rotation 360°
- Design suitable for vacuum applications up to 10<sup>-2</sup> mbar

### OPTIONS

- Manual override (e.g. Code RPG205STWM0) see page 28
- Stroke regulator (e.g. Code RPG210STJR0) see page 28
- Travel switch (e.g. Code RPG208LTZ10) see page 28
- NPT Connection (e.g. Code RPN205STW00)
- Weld ends see page 17

### TYPE: REGULAR NO



### SELECTION TABLE

VALVE	Connection	DN	Flow rate Kvs	Working pressure ①		Flow direction	Pilot pressure ②		Actuator Ø
				min	max		min	max	
Code	[ISO 228 G]	[mm]	[l/min]	[barg]	[barg]	[2 → 1]	[barg]	[barg]	[mm]
RPG205STW00	1/2"	15	87	0	16	under seat	2.5	10	63
RPG206STX00	3/4"	20	164	0	16	under seat	4.3	10	
RPG207STY00	1"	25	260	0	16	under seat	5.5	10	
RPG208STZ00	1 1/4"	32	410	0	16	under seat	6.5	10	
RPG209STK00	1 1/2"	40	700	0	16	under seat	9	10	
RPG210STJ00	2"	50	950	0	12	under seat	9.4	10	
RPG207LTY00	1"	25	260	0	16	under seat	2	8	90
RPG208LTZ00	1 1/4"	32	410	0	16	under seat	4	8	
RPG209LTK00	1 1/2"	40	700	0	16	under seat	5	8	
RPG210LTJ00	2"	50	950	0	16	under seat	7	8	

① Steam: Max. working pressure 10 bar (9 barg); ② Minimum pilot pressure at max. working pressure; for lower working pressure see selection charts

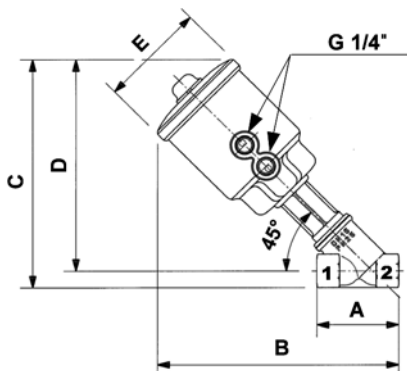

### DIMENSIONS & WEIGHTS

Connection	Actuator Ø	A	B	C	D	E	Weight
[ISO 228 G]	[mm]	[mm]	[mm]	[mm]	[mm]	[mm]	[kg]
1/2"	63	65	192	184	171	85	1.2
3/4"	63	75	198	192	176	85	1.3
1"	63	90	212	205	185	85	1.5
1 1/4"	63	110	225	217	193	85	1.9
1 1/2"	63	120	230	225	198	85	2.1
2"	63	150	248	241	207	85	2.9
1"	90	90	223	216	196	112	2.0
1 1/4"	90	110	234	227	202	112	2.4
1 1/2"	90	120	239	235	207	112	2.6
2"	90	150	257	250	216	112	3.3

## 2/2 WAY PISTON VALVE G 1/2" ÷ 2" BIDIRECTIONAL – STAINLESS STEEL

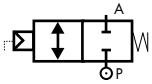

normally closed  
flow over / under seat

### TECHNICAL SPECIFICATIONS

- Media: water, oil, air, aggressive media and steam ❶
- Media temperature: -10°C ÷ +180°C
- Ambient temperature: -10°C ÷ +60°C
- Pilot media: air, inert gases, water
- Body material: AISI 316L (see page 37)
- Bonnet material: AISI 316L (see page 37)
- Actuator body material: Polyamide PA6 (reinforced fiberglass 30%)
- Seal material: PTFE type TFM 1600
- Position indicator as standard
- Valves DN32-DN50 complying with 97/23 Directive Category I

### BENEFITS

- Waterhammer-free design (with flow direction 2→1)
- Actuator housing rotation 360°
- Design suitable for vacuum applications up to 10<sup>-2</sup> mbar

### OPTIONS

- Manual override (e.g. Code BPG205STWM0) see page 28
- Stroke regulator (e.g. Code BPG210STJR0) see page 28
- Travel switch (e.g. Code BPG208LTZ10) see page 28
- NPT Connection (e.g. Code BPN205STW00)
- Weld ends see page 17

### TYPE: REGULAR BD



### SELECTION TABLE

VALVE	Connection	DN	Flow rate Kvs	Working pressure ❶		Flow direction	Pilot pressure ❷		Actuator Ø
				min	max		min	max	
Code	[ISO 228 G]	[mm]	[l/min]	[barg]	[barg]	-	[barg]	[barg]	[mm]
BPG205STW00	1/2"	15	87	0	16	1→2 / 2→1	5.5 / 3.8	10	63
BPG206STX00	3/4"	20	164	0	16	1→2 / 2→1	6 / 3.8	10	
BPG207STY00	1"	25	260	0	16 / 11	1→2 / 2→1	6.5 / 3.8	10	
BPG208STZ00	1 1/4"	32	410	0	16 / 6	1→2 / 2→1	6.8 / 3.8	10	
BPG209STK00	1 1/2"	40	700	0	12 / 4	1→2 / 2→1	9 / 3.8	10	
BPG210STJ00	2"	50	950	0	8 / 2.5	1→2 / 2→1	9 / 3.8	10	
BPG207LTY00	1"	25	260	0	16 / 14	1→2 / 2→1	4 / 3.3	8	90
BPG208LTZ00	1 1/4"	32	410	0	16 / 12	1→2 / 2→1	5 / 3.3	8	
BPG209LTK00	1 1/2"	40	700	0	16 / 8	1→2 / 2→1	6 / 3.3	8	
BPG210LTJ00	2"	50	950	0	14 / 6	1→2 / 2→1	8 / 3.3	8	

❶ Steam: Max. working pressure 10 bar (9 barg); ❷ Minimum pilot pressure at max. working pressure; for lower working pressure see selection charts

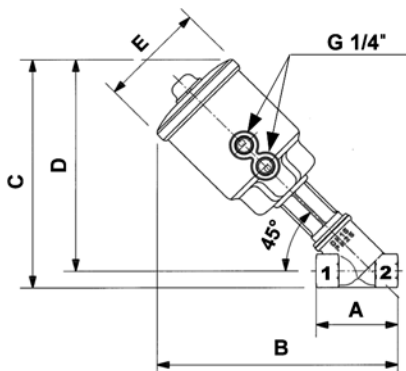

### DIMENSIONS & WEIGHTS

Connection	Actuator Ø	A	B	C	D	E	Weight
[ISO 228 G]	[mm]	[mm]	[mm]	[mm]	[mm]	[mm]	[kg]
1/2"	63	65	192	184	171	85	1.2
3/4"	63	75	198	192	176	85	1.3
1"	63	90	212	205	185	85	1.5
1 1/4"	63	110	225	217	193	85	1.9
1 1/2"	63	120	230	225	198	85	2.1
2"	63	150	248	241	207	85	2.9
1"	90	90	223	216	196	112	2.0
1 1/4"	90	110	234	227	202	112	2.4
1 1/2"	90	120	239	235	207	112	2.6
2"	90	150	257	250	216	112	3.3

## 2/2 WAY PISTON VALVE G 1/2" ÷ 2" DOUBLE ACTING – STAINLESS STEEL

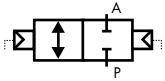

double acting  
flow over / under seat

### TECHNICAL SPECIFICATIONS

- Media: water, oil, air, aggressive media and steam ❶
- Media temperature: -10°C ÷ +180°C
- Ambient temperature: -10°C ÷ +60°C
- Pilot media: air, inert gases, water
- Body material: AISI 316L (see page 37)
- Bonnet material: AISI 316L (see page 37)
- Actuator body material: Polyamide PA6 (reinforced fiberglass 30%)
- Seal material: PTFE type TFM 1600
- Position indicator as standard
- Valves DN32-DN50 complying with 97/23 Directive Category I

### BENEFITS

- Waterhammer-free design (with flow direction 2→1)
- Actuator housing rotation 360°
- Design suitable for vacuum applications up to 10<sup>-2</sup> mbar

### OPTIONS

- Manual override (e.g. Code RPG205STWM0) see page 28
- Stroke regulator (e.g. Code RPG210STJR0) see page 28
- Travel switch (e.g. Code RPG208LTZ10) see page 28
- NPT Connection (e.g. Code RPN205STW00)
- Weld ends see page 17

### TYPE: REGULAR DA



### SELECTION TABLE

VALVE	Connection	DN	Flow rate Kvs	Working pressure ❶		Flow direction	Pilot pressure ❷		Actuator Ø
				min	max		min	max	
Code	[ISO 228 G]	[mm]	[l/min]	[barg]	[barg]	-	min [barg]	max [barg]	[mm]
DCG205STW00	1/2"	15	87	0	16	1 ↔ 2	1.8	2	63
DCG206STX00	3/4"	20	164	0	16	1 ↔ 2	2	3.8	
DCG207STY00	1"	25	260	0	16	1 ↔ 2	3	5	
DCG208STZ00	1 1/4"	32	410	0	16	1 ↔ 2	4.5	6	
DCG209STK00	1 1/2"	40	700	0	16	1 ↔ 2	6.5	7	
DCG210STJ00	2"	50	950	0	12	1 ↔ 2	9	10	

❶ Steam: Max. working pressure 10 bar (9 barg); ❷ Minimum pilot pressure at max. working pressure; for lower working pressure see selection charts

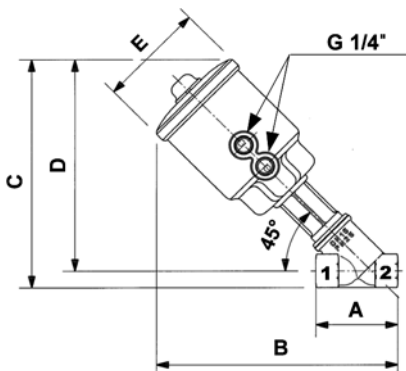

### DIMENSIONS & WEIGHTS

Connection	Actuator Ø	A	B	C	D	E	Weight
[ISO 228 G]	[mm]	[mm]	[mm]	[mm]	[mm]	[mm]	[kg]
1/2"	63	65	192	184	171	85	1.2
3/4"	63	75	198	192	176	85	1.3
1"	63	90	212	205	185	85	1.5
1 1/4"	63	110	225	217	193	85	1.9
1 1/2"	63	120	230	225	198	85	2.1
2"	63	150	248	241	207	85	2.9

## MANUAL ANGLE SEAT VALVE G 1/2" ÷ 2" – STAINLESS STEEL

flow over/ under seat

### TECHNICAL SPECIFICATIONS

Media: water, oil, air, aggressive media and steam <sup>❶</sup>

Media temperature: -10°C ÷ +180°C

Ambient temperature: -10°C ÷ +60°C

Body material: AISI 316L (see page 37)

Bonnet material: AISI 316L (see page 37)

Seal material: PTFE type TFM 1600

### OPTIONS

NPT Connection (e.g. Code PN2050TW00)

### TYPE: PG MANUAL



### SELECTION TABLE

VALVE	Connection	DN	Flow rate Kvs	Working pressure <sup>❶</sup>		Flow direction
				min	max	
Code	[ISO 228 G]	[mm]	[l/min]	[barg]	[barg]	-
PG2050TW00	1/2"	15	87	0	40	1 ↔ 2
PG2060TX00	3/4"	20	164	0	40	1 ↔ 2
PG2070TY00	1"	25	260	0	40	1 ↔ 2
PG2080TZ00	1 1/4"	32	410	0	25	1 ↔ 2
PG2090TK00	1 1/2"	40	700	0	25	1 ↔ 2
PG2100TJ00	2"	50	916	0	16	1 ↔ 2

<sup>❶</sup> Steam: Max. working pressure 10 bar (9 barg);

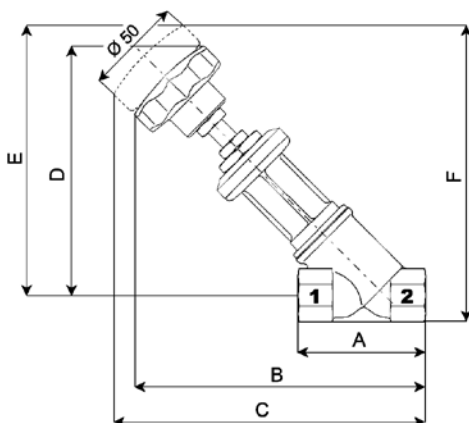

### DIMENSIONS & WEIGHTS

Connection	A	B	C	D	E	F	Weight
[ISO 228 G]	[mm]	[mm]	[mm]	[mm]	[mm]	[mm]	[kg]
1/2"	65	142	150	121	128	141	0.75
3/4"	75	148	155	126	133	150	0.80
1"	90	163	172	135	145	165	1.20
1 1/4"	110	175	188	143	156	181	1.80
1 1/2"	120	180	193	148	161	189	2.10
2"	150	198	212	157	170	205	3.10



## 2/2 WAY PISTON VALVE WITH WELDING CONNECTION – AISI 316L

### TECHNICAL SPECIFICATIONS

See general features at pages 11, 12, 13, 14, 15

### OPTIONS

Weld connection for DIN 3239 pipe (e.g. Code BPE205STW00)

Manual override (e.g. Code PS205STW0M0) see page 28

Stroke regulator (e.g. Code BPB210STJR0) see page 28

Travel switch (e.g. Code RPW208LTZ0) see page 28

High temperature version (e.g. Code PS205STW0H)

TYPE: ALL TYPES



### SELECTION TABLE

DN	SOCKET WELD for ISO 65/ANSI B 36.10 pipe			BUTT WELD for ISO 65/ANSI B 36.10 pipe			BUTT WELD for DIN 11850 pipe			BUTT WELD for ISO 4200 pipe		
	Actuator Ø 45	Actuator Ø 63	Actuator Ø 90	Actuator Ø 45	Actuator Ø 63	Actuator Ø 90	Actuator Ø 45	Actuator Ø 63	Actuator Ø 90	Actuator Ø 45	Actuator Ø 63	Actuator Ø 90
[mm]	Code	Code	Code	Code	Code	Code	Code	Code	Code	Code	Code	Code
15	PS205CTW00	PS205STW00	—	PB205CTW00	PB205STW00	—	PW205CTW00	PW205STW00	—	PH205CTW00	PH205STW00	—
20	PS206CTX00	PS206STX00	—	PB206CTX00	PB206STX00	—	PW206CTX00	PW206STX00	—	PH206CTX00	PH206STX00	—
25	—	PS207STY00	PS207LTY00	—	PB207STY00	PB207LTY00	—	PW207STY00	PW207LTY00	—	PH207STY00	PH207LTY00
32	—	PS208STZ00	PS208LTZ00	—	PB208STZ00	PB208LTZ00	—	PW208STZ00	PW208LTZ00	—	PH208STZ00	PH208LTZ00
40	—	PS209STK00	PS209LTK00	—	PB209STK00	PB209LTK00	—	PW209STK00	PW209LTK00	—	PH209STK00	PH209LTK00
50	—	PS210STJ00	PS210LTJ00	—	PB210STJ00	PB210LTJ00	—	PW210STJ00	PW210LTJ00	—	PH210STJ00	PH210LTJ00

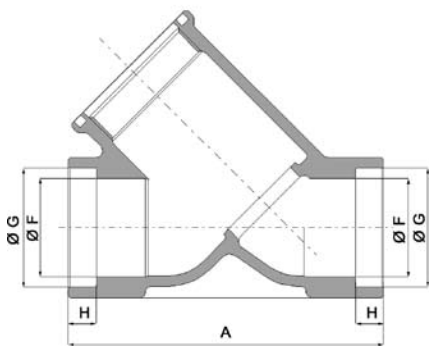

Valve with socket weld connection for ISO 65/ANSI B 36.10 pipe

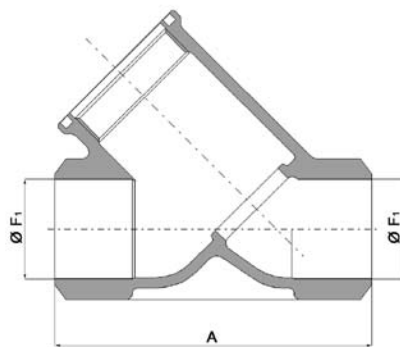

Valve with butt weld connection for ISO 65/ANSI B 36.10 pipe  
Welding ends complying with ISO 6761

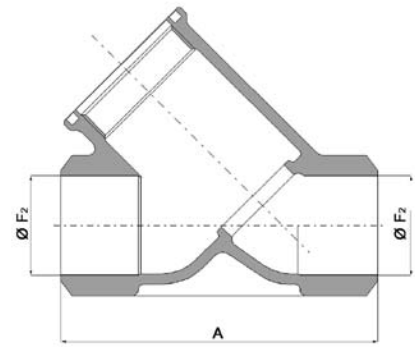

Valve with butt weld connection for DIN 11850 pipe  
Welding ends complying with ISO 6761

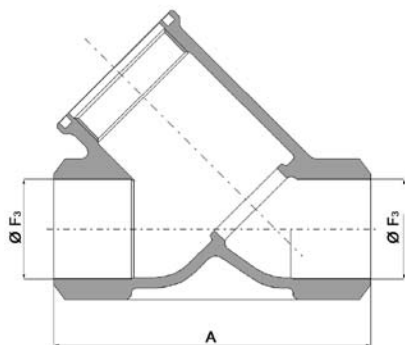

Valve with butt weld connection for ISO 4200 pipe  
Welding ends complying with ISO 6761

### DIMENSIONS

Actuator Ø	DN	A	Ø F	Ø F1	Ø F2	Ø F3	Ø G	H
[mm]	[mm]	[mm]	[mm]	[mm]	[mm]	[mm]	[mm]	[mm]
45	15	65	17.4	17.4	16	18.1	22	5
	20	75	22.8	22.8	20	23.7	27.5	7
63	15	65	17.4	17.4	16	18.1	22	5
	20	75	22.8	22.8	20	23.7	27.5	7
	25	90	28.3	28.3	26	29.7	34	8
	32	110	37.1	37.1	32	38.4	43	10
	40	120	42.7	42.7	38	44.3	49	12
90	50	150	54.8	54.8	50	55.1	61.5	16
	25	90	28.3	28.3	26	29.7	34	8
	32	110	37.1	37.1	32	38.4	43	10
	40	120	42.7	42.7	38	44.3	49	12
	50	150	54.8	54.8	50	55.1	61.5	16

Note: For overall dimensions please refer to pages 11, 12, 13, 14, 15.

## 2/2 WAY PISTON VALVE WITH FLANGED CONNECTION - AISI 316L

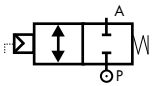

NC normally closed  
bidirectional

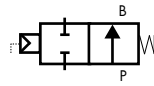

NO normally open  
under seat flow

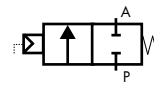

NC normally closed  
over seat flow

### TECHNICAL SPECIFICATIONS

See general features at pages 11, 12, 13, 14, 15

Valves DN32-DN50 complying with 97/23 Directive Category I

### BENEFITS

Waterhammer-free design for BPA - BPD type (2→1)

### OPTIONS

Manual override (e.g. Code BPA205STW00) see page 28

Stroke regulator (e.g. Code PD210STJR0) see page 28

Travel switch (e.g. Code RPG208LTZ0) see page 28

High temperature version (e.g. Code PD205STW0H)

### TYPE: REGULAR (BD-NO-NC)



SELECTION TABLE

#### FLANGES TO BS 4504 (EN1092 shape B)

DN	ACTUATOR Ø 63			ACTUATOR Ø 90		
	BD	NC	NO	BD	NC	NO
[mm]	Code	Code	Code	Code	Code	Code
15	BPD205STW00	PD205STW00	RPD205STW00	–	–	–
20	BPD206STX00	PD206STX00	RPD206STX00	–	–	–
25	BPD207STY00	PD207STY00	RPD207STY00	BPD207LTY00	PD207LTY00	RPD207LTY00
32	BPD208STZ00	PD208STZ00	RPD208STZ00	BPD208LTZ00	PD208LTZ00	RPD208LTZ00
40	BPD209STK00	PD209STK00	RPD209STK00	BPD209LTK00	PD209LTK00	RPD209LTK00
50	BPD210STJ00	PD210STJ00	RPD210STJ00	BPD210LTJ00	PD210LTJ00	RPD210LTJ00

#### FLANGES TO ANSI B16.5 CLASS 150

DN	ACTUATOR Ø 63			ACTUATOR Ø 90		
	BD	NC	NO	BD	NC	NO
[mm]	Code	Code	Code	Code	Code	Code
15	BPA205STW00	PA205STW00	RPA205STW00	–	–	–
20	BPA206STX00	PA206STX00	RPA206STX00	–	–	–
25	BPA207STY00	PA207STY00	RPA207STY00	BPA207LTY00	PA207LTY00	RPA207LTY00
32	BPA208STZ00	PA208STZ00	RPA208STZ00	BPA208LTZ00	PA208LTZ00	RPA208LTZ00
40	BPA209STK00	PA209STK00	RPA209STK00	BPA209LTK00	PA209LTK00	RPA209LTK00
50	BPA210STJ00	PA210STJ00	RPA210STJ00	BPA210LTJ00	PA210LTJ00	RPA210LTJ00

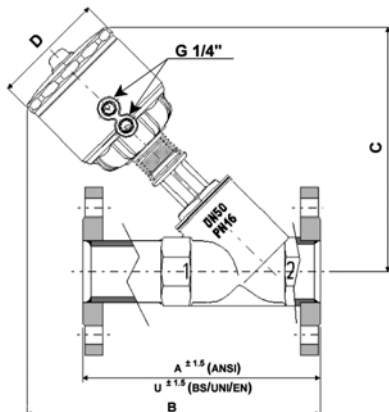

DIMENSIONS & WEIGHTS

DN	Actuator Ø	A* (ANSI)	U* (ANSI)	B	C	D	Weight
[mm]	[mm]	[mm]	[mm]	[mm]	[mm]	[mm]	[kg]
15	63	139.7	130	218	194	85	2.6
20	63	152.4	150	236	210	85	3.0
25	63	165.1	160	239	208	85	3.8
32	63	184.2	180	252	216	85	5.6
40	63	203.2	200	257	220	85	6.9
50	63	228.6	230	275	230	85	8.7
25	90	165.1	160	250	219	112	4.4
32	90	184.2	180	263	227	112	6.0
40	90	203.2	200	268	232	112	6.9
50	90	228.6	230	286	240	112	9.1

\*A: face to face to ANSI B 16.10 \*U: face to face to EN 558-1

## 2/2 WAY PISTON VALVE WITH CLAMP-END CONNECTION – AISI 316L



### TECHNICAL SPECIFICATIONS

- Media: water, oil, air, aggressive media and steam
- Media temperature:  $-10^{\circ}\text{C} \div +180^{\circ}\text{C}$
- Ambient temperature:  $-10^{\circ}\text{C} \div +60^{\circ}\text{C}$
- Pilot media: air, inert gases
- Body material: cast AISI 316L (see page 37)
- Clamp material: AISI 316L
- Bonnet material: cast AISI 316L (see page 37)
- Actuator body material: Polyamide PA6 (reinforced fiberglass 30%)
- Seal material: PTFE type TFM 1600
- Position indicator as standard
- Gasket and clamp not included
- Connection to ISO 2852 or ASME BPE

### TYPE: COMPACT AND REGULAR (BD-NO-NC)



### BENEFITS

- Waterhammer-free design for BPC - BPP type (2→1)
- Actuator housing rotation  $360^{\circ}$
- Design suitable for vacuum applications up to  $10^{-2}$  mbar

### OPTIONS

- Manual override (e.g. Code BPC205STWM0) see page 28
- Stroke regulator (e.g. Code PC210STJR0) see page 28
- Travel switch (e.g. Code RPC208LTZI0) see page 28

### SELECTION TABLE

DN	ISO 2852								
	ACTUATOR Ø 45			ACTUATOR Ø 63			ACTUATOR Ø 90		
	BD	NC	NC	BD	NC	NO	BD	NC	NO
[mm]	Code	Code	Code	Code	Code	Code	Code	Code	Code
15	BPC205CTW00	PC205CTW00	RPC205CTW00	BPC205STW00	PC205STW00	RPC205STW00	–	–	–
20	BPC206CTX00	PC206CTX00	RPC206CTX00	BPC206STX00	PC206STX00	RPC206STX00	–	–	–
25	–	–	–	BPC207STY00	PC207STY00	RPC207STY00	BPC207LTY00	PC207LTY00	RPC207LTY00
32	–	–	–	BPC208STZ00	PC208STZ00	RPC208STZ00	BPC208LTZ00	PC208LTZ00	RPC208LTZ00
40	–	–	–	BPC209STK00	PC209STK00	RPC209STK00	BPC209LTK00	PC209LTK00	RPC209LTK00
50	–	–	–	BPC210STJ00	PC210STJ00	RPC210STJ00	BPC210LTJ00	PC210LTJ00	RPC210LTJ00

DN	ASME BPE								
	ACTUATOR Ø 45			ACTUATOR Ø 63			ACTUATOR Ø 90		
	BD	NC	NC	BD	NC	NO	BD	NC	NO
[mm]	Code	Code	Code	Code	Code	Code	Code	Code	Code
15	BPP205CTW00	PP205CTW00	RPP205CTW00	BPP205STW00	PP205STW00	RPP205STW00	–	–	–
20	BPP206CTX00	PP206CTX00	RPP206CTX00	BPP206STX00	PP206STX00	RPP206STX00	–	–	–
25	–	–	–	BPP207STY00	PP207STY00	RPP207STY00	BPP207LTY00	PP207LTY00	RPP207LTY00
40	–	–	–	BPP209STK00	PP209STK00	RPP209STK00	BPP209LTK00	PP209LTK00	RPP209LTK00
50	–	–	–	BPP210STJ00	PP210STJ00	RPP210STJ00	BPP210LTJ00	PP210LTJ00	RPP210LTJ00

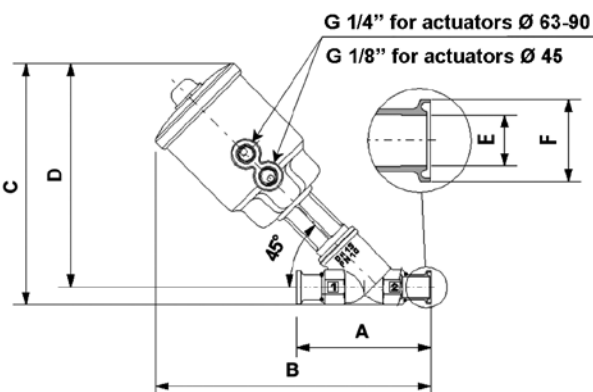

### DIMENSIONS & WEIGHTS

DN	Actuator Ø	A ISO	A ASME	B ISO	B ASME	C ISO	C ASME	D	E ISO	E ASME	F ISO	F ASME	Weight	Weight
[mm]	[mm]	[mm]	[mm]	[mm]	[mm]	[mm]	[mm]	[mm]	[mm]	[mm]	[mm]	[mm]	[kg]	[kg]
15	45	102	102	162	162	140	136	123	17.2	9.4	34	25	0.83	0.83
20	45	114	114	167	167	142	138	125	21.3	15.75	34	25	1.1	1.1
15	63	102	102	210	210	187	183	170	17.2	9.4	34	25	1.3	1.3
20	63	114	114	217	217	193	189	176	21.3	15.75	34	25	1.5	1.5
25	63	140	140	231	231	211	211	185	25	22.1	50.5	50.5	1.8	1.8
32	63	159	–	240	–	218	–	192	33.7	–	50.5	–	2.4	–
40	63	159	159	249	249	229	223	197	40	34.8	64	50.5	2.8	2.8
50	63	190	190	267	267	240	240	206	51	47.5	64	64	3.6	3.6
25	90	140	140	243	243	222	222	196	25	22.1	50.5	50.5	2.4	2.4
32	90	159	–	251	–	230	–	204	33.7	–	50.5	–	2.8	–
40	90	159	159	260	260	241	235	209	40	34.8	64	50.5	3.2	3.2
50	90	190	190	279	279	251	251	217	51	47.5	64	64	4.0	4.0

## PERFORMANCE TABLE ASME BPE VERSION

**BD**

VALVE	Actuator Ø	DN	Flow rate Kvs	Working pressure		Flow direction	Pilot pressure ①	
				min	max		min	max
Code	[mm]	[mm]	[l/min]	[barg]	[barg]	-	[barg]	[barg]
BPP205CTW00	45	15	50	0	10 / 10	1→2 / 2→1	6.2 / 5	10
BPP206CTX00	45	20	120	0	10 / 7	1→2 / 2→1	8.7 / 5	10
BPP205STW00	63	15	50	0	10 / 10	1→2 / 2→1	5.5 / 3.8	10
BPP206STX00	63	20	135	0	10 / 10	1→2 / 2→1	6 / 3.8	10
BPP207STY00	63	25	250	0	10 / 10	1→2 / 2→1	6.5 / 3.8	10
BPP209STK00	63	40	640	0	10 / 4	1→2 / 2→1	9 / 3.8	10
BPP210STJ00	63	50	730	0	8 / 2.5	1→2 / 2→1	9 / 3.8	10
BPP207LTY00	90	25	250	0	10 / 10	1→2 / 2→1	4 / 3.3	8
BPP209LTK00	90	40	640	0	10 / 8	1→2 / 2→1	6 / 3.3	8
BPP210LTJ00	90	50	730	0	10 / 6	1→2 / 2→1	8 / 3.3	8

**NC**

VALVE	Actuator Ø	DN	Flow rate Kvs	Working pressure		Flow direction	Pilot pressure ①	
				min	max		min	max
Code	[mm]	[mm]	[l/min]	[barg]	[barg]	[1→2]	[barg]	[barg]
PP205CTW00	45	15	50	0	10	over seat	3.8	10
PP206CTX00	45	20	120	0	10	over seat	5.8	10
PP205STW00	63	15	50	0	10	over seat	3.7	10
PP206STX00	63	20	135	0	10	over seat	4.4	10
PP207STY00	63	25	250	0	10	over seat	5.9	10
PP209STK00	63	40	640	0	10	over seat	9	10
PP210STJ00	63	50	730	0	10	over seat	8	10
PP207LTY00	90	25	250	0	10	over seat	2	8
PP209LTK00	90	40	640	0	10	over seat	4	8
PP210LTJ00	90	50	730	0	10	over seat	6.5	8

**NO**

VALVE	Actuator Ø	DN	Flow rate Kvs	Working pressure		Flow direction	Pilot pressure ①	
				min	max		min	max
Code	[mm]	[mm]	[l/min]	[barg]	[barg]	[2→1]	[barg]	[barg]
RPP205CTW00	45	15	50	0	10	under seat	6.2 / 5	10
RPP206CTX00	45	20	120	0	10	under seat	8.7 / 5	10
RPP205STW00	63	15	50	0	10	under seat	5.5 / 3.8	10
RPP206STX00	63	20	135	0	10	under seat	6 / 3.8	10
RPP207STY00	63	25	250	0	10	under seat	6.5 / 3.8	10
RPP209STK00	63	40	640	0	10	under seat	9 / 3.8	10
RPP210STJ00	63	50	730	0	10	under seat	9 / 3.8	10
RPP207LTY00	90	25	250	0	10	under seat	4 / 3.3	8
RPP209LTK00	90	40	640	0	10	under seat	6 / 3.3	8
RPP210LTJ00	90	50	730	0	10	under seat	8 / 3.3	8

① Minimum pilot pressure at max working pressure; for lower working pressure see selection chart of "PAV" M&M Catalogue.  
For the different code: e. g. PP205STW00 see the equivalent code PG205STW00.

## PERFORMANCE TABLE ISO 2852 VERSION

**BD**

VALVE	Actuator Ø	DN	Flow rate Kvs	Working pressure		Flow direction	Pilot pressure ①	
				min	max		min	max
Code	[mm]	[mm]	[l/min]	[barg]	[barg]	-	[barg]	[barg]
BPC205CTW00	45	15	65	0	10 / 10	1→2 / 2→1	6.2 / 5	10
BPC206CTX00	45	20	120	0	10 / 7	1→2 / 2→1	8.7 / 5	10
BPC205STW00	63	15	85	0	10 / 10	1→2 / 2→1	5.5 / 3.8	10
BPC206STX00	63	20	160	0	10 / 10	1→2 / 2→1	6 / 3.8	10
BPC207STY00	63	25	260	0	10 / 10	1→2 / 2→1	6.5 / 3.8	10
BPC208STZ00	63	32	420	0	10 / 6	1→2 / 2→1	6.8 / 3.8	10
BPC209STK00	63	40	700	0	10 / 4	1→2 / 2→1	9 / 3.8	10
BPC210STJ00	63	50	810	0	8 / 2.5	1→2 / 2→1	9 / 3.8	10
BPC207LTY00	90	25	260	0	10 / 10	1→2 / 2→1	4 / 3.3	8
BPC208LTZ00	90	32	420	0	10 / 10	1→2 / 2→1	5 / 3.3	8
BPC209LTK00	90	40	700	0	10 / 8	1→2 / 2→1	6 / 3.3	8
BPC210LTJ00	90	50	810	0	10 / 6	1→2 / 2→1	8 / 3.3	8

**NC**

VALVE	Actuator Ø	DN	Flow rate Kvs	Working pressure		Flow direction	Pilot pressure ①	
				min	max		min	max
Code	[mm]	[mm]	[l/min]	[barg]	[barg]	[1→2]	[barg]	[barg]
PC205CTW00	45	15	65	0	10	over seat	3.8	10
PC206CTX00	45	20	120	0	10	over seat	5.8	10
PC205STW00	63	15	85	0	10	over seat	3.7	10
PC206STX00	63	20	160	0	10	over seat	4.4	10
PC207STY00	63	25	260	0	10	over seat	5.9	10
PC208STZ00	63	32	420	0	10	over seat	9	10
PC209STK00	63	40	700	0	10	over seat	9	10
PC210STJ00	63	50	810	0	10	over seat	8	10
PC207LTY00	90	25	260	0	10	over seat	2	8
PC208LTZ00	90	32	420	0	10	over seat	3.5	8
PC209LTK00	90	40	700	0	10	over seat	4	8
PC210LTJ00	90	50	810	0	10	over seat	6.5	8

**NO**

VALVE	Actuator Ø	DN	Flow rate Kvs	Working pressure		Flow direction	Pilot pressure ①	
				min	max		min	max
Code	[mm]	[mm]	[l/min]	[barg]	[barg]	[2→1]	[barg]	[barg]
RPC205CTW00	45	15	65	0	10	under seat	4	10
RPC206CTX00	45	20	120	0	10	under seat	6.2	10
RPC205STW00	63	15	85	0	10	under seat	2.5	10
RPC206STX00	63	20	160	0	10	under seat	4.3	10
RPC207STY00	63	25	260	0	10	under seat	5.5	10
RPC208STZ00	63	32	420	0	10	under seat	6.5	10
RPC209STK00	63	40	700	0	10	under seat	9	10
RPC210STJ00	63	50	810	0	10	under seat	9.4	10
RPC207LTY00	90	25	260	0	10	under seat	3	8
RPC208LTZ00	90	32	420	0	10	under seat	4	8
RPC209LTK00	90	40	700	0	10	under seat	5	8
RPC210LTJ00	90	50	810	0	10	under seat	7	8

① Minimum pilot pressure at max working pressure; for lower working pressure see selection chart of "PAV" M&M Catalogue..  
For the different code: e. g. PC205STW00 see the equivalent code PG205STW00.



## 2/2 WAY PISTON VALVE G 1/2" ÷ 2" – AISI 316L HIGH TEMPERATURE VERSION

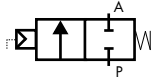

normally closed  
flow over seat

### TECHNICAL SPECIFICATIONS

- Media: water, oil, air, aggressive media and steam ❶
- Media temperature: -10°C ÷ +200°C
- Ambient temperature: -10°C ÷ +60°C
- Pilot media: air, inert gases
- Body material: cast AISI 316L (see page 37)
- Bonnet material: cast AISI 316L (see page 37)
- Actuator body material: Polyamide PA66 (reinforced fiberglass 30%)
- Seal material: PTFE type TFM 1600
- Position indicator as standard
- Valves DN32-DN50 complying with 97/23 Directive Category I

### BENEFITS

Actuator housing rotation 360°

### OPTIONS

- Manual override (e.g. Code PG205STW0MH) see page 28
- Stroke regulator (e.g. Code PG210STJR0H) see page 28
- Travel switch (e.g. Code PG208LTZ0H) see page 28
- NPT Connection (e.g. Code PN205STW0H)
- Optional connections see pages: weld ends 17, flange 18, clamp 19 ÷ 21

### TYPE: REGULAR HIGH TEMPERATURE (NC)



### SELECTION TABLE

VALVE	Connection	DN	Flow rate Kvs	Working pressure ❶		Flow direction	Pilot pressure ❷		Actuator Ø
				min	max		min	max	
Code	[ISO 228 G]	[mm]	[l/min]	[barg]	[barg]	[1 → 2]	[barg]	[barg]	[mm]
PG205STW0H	1/2"	15	87	0	20	over seat	3.7	10	63
PG206STX0H	3/4"	20	164	0	20	over seat	4.4	10	
PG207STY0H	1"	25	260	0	20	over seat	5	10	
PG208LTZ0H	1 1/4"	32	410	0	16	over seat	3.5	8	90
PG209LTK0H	1 1/2"	40	700	0	16	over seat	4	8	
PG210LTJ0H	2"	50	950	0	15	over seat	6.5	8	

❶ Steam: Max. working pressure 14.5 barg; ❷ Minimum pilot pressure at max. working pressure; for lower working pressure see selection charts

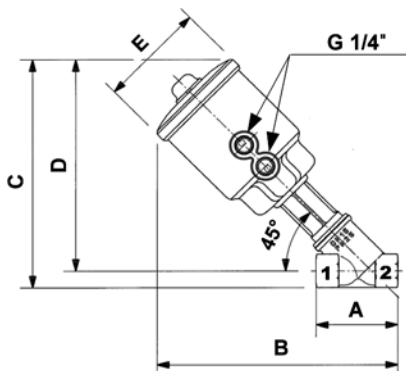

### DIMENSIONS & WEIGHTS

Connection	Actuator Ø	A	B	C	D	E	Weight
[ISO 228 G]	[mm]	[mm]	[mm]	[mm]	[mm]	[mm]	[kg]
1/2"	63	65	192	184	171	85	1.2
3/4"	63	75	198	192	176	85	1.3
1"	63	90	212	205	185	85	1.5
1 1/4"	90	110	234	227	202	112	2.4
1 1/2"	90	120	239	235	207	112	2.6
2"	90	150	257	250	216	112	3.3

## 2/2 WAY PISTON VALVE G 1/2" ÷ 2" – AISI 316L HIGH TEMPERATURE VERSION

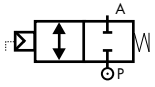

normally closed  
flow over / under seat

### TECHNICAL SPECIFICATIONS

- Media: water, oil, air, aggressive media and steam ❶
- Media temperature: -10°C ÷ +200°C
- Ambient temperature: -10°C ÷ +60°C
- Pilot media: air, inert gases
- Body material: cast AISI 316L (see page 37)
- Bonnet material: cast AISI 316L (see page 37)
- Actuator body material: Polyamide PA66 (reinforced fiberglass 30%)
- Seal material: PTFE type TFM 1600
- Position indicator as standard
- Valves DN32-DN50 complying with 97/23 Directive Category I

### BENEFITS

- Actuator housing rotation 360°
- Waterhammer-free design (with flow direction 2→1)

### OPTIONS

- Manual override (e.g. Code BPG205STW[M]H) see page 28
- Stroke regulator (e.g. Code BPG210STJ[R]H) see page 28
- Travel switch (e.g. Code BPG208LTZ[I]H) see page 28
- NPT Connection (e.g. Code BPN205STW0H)
- Optional connections see pages: weld ends 17, flange 18, clamp 19 ÷ 21

### TYPE: REGULAR HIGH TEMPERATURE (BD)



### SELECTION TABLE

VALVE	Connection	DN	Flow rate Kvs	Working pressure ❶		Flow direction	Pilot pressure ❷		Actuator Ø
				min	max		min	max	
Code	[ISO 228 G]	[mm]	[l/min]	[barg]	[barg]	-	[barg]	[barg]	[mm]
BPG205STW0H	1/2"	15	87	0	16	1→2 / 2→1	5.5 / 3.8	10	63
BPG206STX0H	3/4"	20	164	0	16	1→2 / 2→1	6 / 3.8	10	
BPG207STY0H	1"	25	260	0	16 / 11	1→2 / 2→1	6.5 / 3.8	10	
BPG208LTZ0H	1 1/4"	32	410	0	16 / 12	1→2 / 2→1	5 / 3.3	8	90
BPG209LTK0H	1 1/2"	40	700	0	16 / 8	1→2 / 2→1	6 / 3.3	8	
BPG210LTJ0H	2"	50	950	0	14 / 6	1→2 / 2→1	8 / 3.3	8	

❶ Steam: Max. working pressure 14.5 barg; ❷ Minimum pilot pressure at max. working pressure; for lower working pressure see selection charts

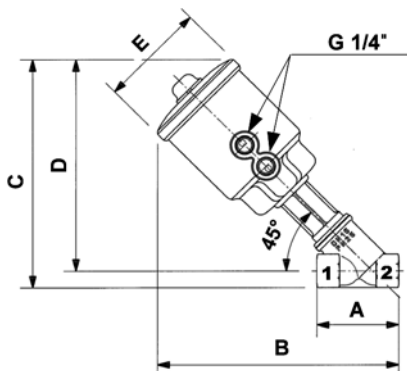

### DIMENSIONS & WEIGHTS

Connection	Actuator Ø	A	B	C	D	E	Weight
[ISO 228 G]	[mm]	[mm]	[mm]	[mm]	[mm]	[mm]	[kg]
1/2"	63	65	192	184	171	85	1.2
3/4"	63	75	198	192	176	85	1.3
1"	63	90	212	205	185	85	1.5
1 1/4"	90	110	234	227	202	112	2.4
1 1/2"	90	120	239	235	207	112	2.6
2"	90	150	257	250	216	112	3.3

## STAINLESS STEEL ACTUATORS FOR M&M PAV SERIE M AND G, DN 15 ÷ 50 FOR USE IN POTENTIALLY EXPLOSIVE ATMOSPHERES - II 2 GD c TX CLASS -

Compact stainless steel actuators available in two sizes: Ø 63 and Ø 90.

Suitable for demanding installations where the use of metallic components is recommended because of the presence of chemical agents in the atmosphere, in case of frequent cleaning operations or if there is the necessity to avoid any accidental collision. These actuators are suitable for any M&M PAV body version: threaded (GAS, NPT), with weld ends (butt/socket), flanged, with clamp ends.

### TECHNICAL SPECIFICATIONS

Protection class: II 2 GD c TX
Media: water, oil, air, aggressive media and steam
Media temperature: -10°C ÷ +180°C (standard version)
Media temperature: -10°C ÷ +200°C (high temperature version)
Ambient temperature: -10°C ÷ +80°C
Pilot media: air, inert gases
Actuator body material: ASTM A 351 CF8 (AISI 304)
Position indicator as standard
Valves DN32-DN50 complying with 97/23 Directive Category I

### BENEFITS

Actuator housing rotation 360°
High resistance to external agents, shocks

### OPTIONS

Version suitable for low ambient/media temperature (e.g. Code BPG207MTY0L)
--

For more general information and technical specifications, please refer to our standard valve data sheets.

For example: **PG205MTW00** (actuator Ø 63) matches with PG205STW00, and **PG210GTJ00** (actuator Ø 90) matches with PG210LTJ00.

Pos.	Description	Material
1	Transparent cup	Polycarbonate
2	Spring	Galvanized stainless steel
3	Red position indicator	PA6 reinforced fiberglass 30%
4	Seal	FKM
5	Actuator cap	ASTM A 351 CF8 (AISI 304)
6	Actuator housing	ASTM A 351 CF8 (AISI 304)
7	Piston	Alluminium
8	Locknut	AISI 303

### SERIE M AND G

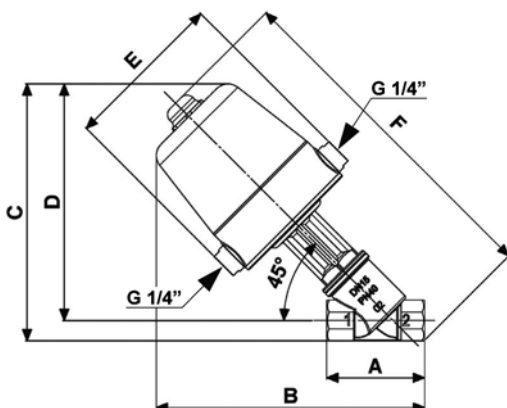
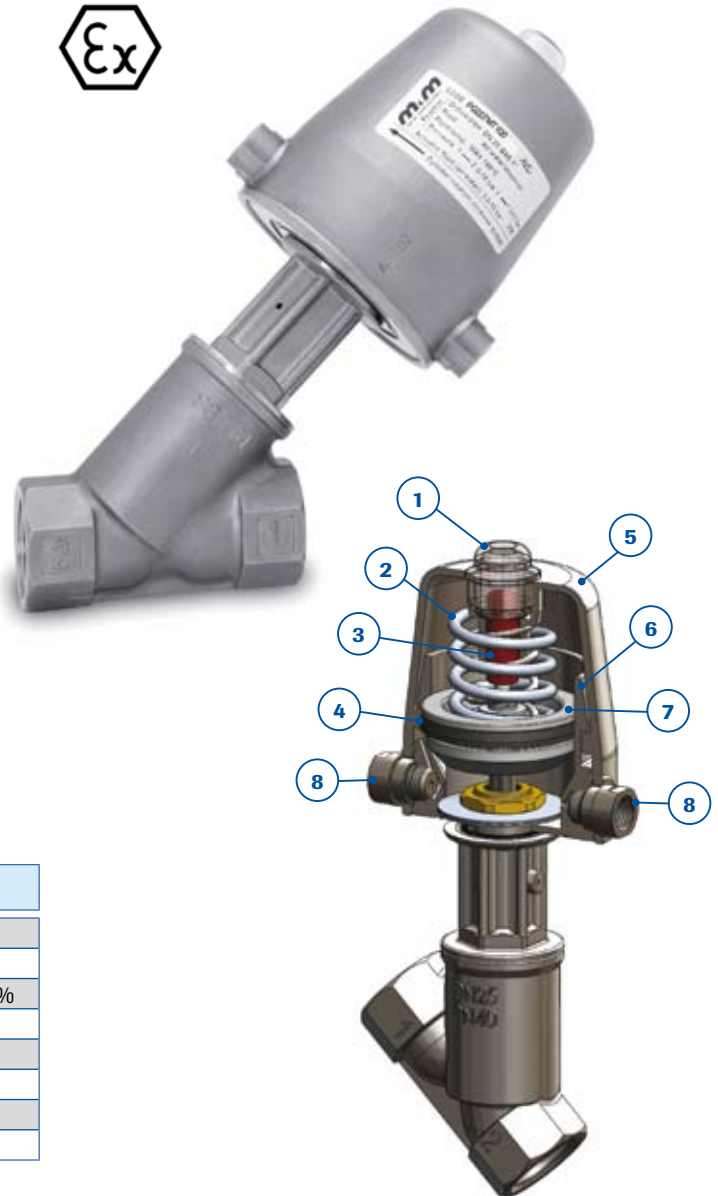

### DIMENSIONS & WEIGHTS

Connection	Actuator Ø	A	B	C	D	E	F	Weight
[ISO 228 G]	[mm]	[mm]	[mm]	[mm]	[mm]	[mm]	[mm]	[kg]
1/2"	63	65	178	171	157	108	228	2.3
3/4"	63	75	184	178	162	108	239	2.4
1"	63	90	200	200	172	108	258	2.6
1 1/4"	63	110	211	204	180	108	275	3.1
1 1/2"	63	120	216	212	184	108	284	3.4
2"	63	150	234	227	193	108	307	4.1
1"	90	90	208	201	181	135	260	3.6
1 1/4"	90	110	221	213	189	135	278	4.1
1 1/2"	90	120	226	221	194	135	286	4.3
2"	90	150	244	236	202	135	310	5.1

## CONTROL PISTON ACTUATED VALVE WITH INTEGRATED POSITIONER

### OPERATING PRINCIPLES AND DESCRIPTION

The M&M control piston actuated valve is operated by a compact pneumatic integrated positioner working in a closed loop. PICTURE A shows the operating layout; the set-point signal (coming from the control panel of the plant) is compared with the internal signal (feed-back) of the position sensor. When the 2 values don't match, the electronic system inside the valve operates no. 2 microvalves (which open or close the pilot air feeding) to change the stroke until both signals match.

The proportionality between the stroke of the valve and the instantaneous flow is guaranteed by the special plug design: linear plug and equal percentage plug (PICTURE B1; the graphs show an ideal curve, which cannot be reproduced exactly but it varies according to the DN of the valve and the specific installation parameters). When fully closed the valve is leakage tight, thanks to the main seal in TFM 1600 as in M&M standard on/off piston valves (see PICTURE B).

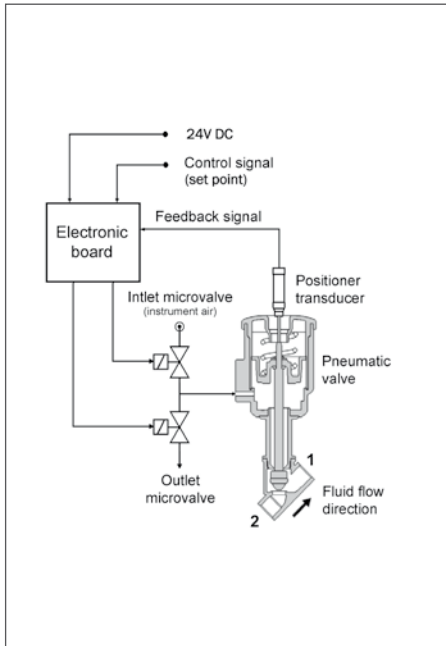

PICTURE A

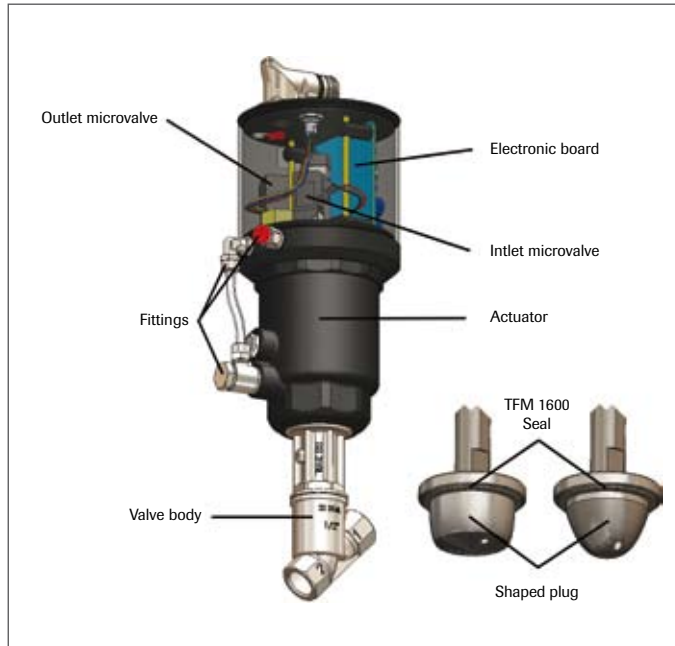

PICTURE B

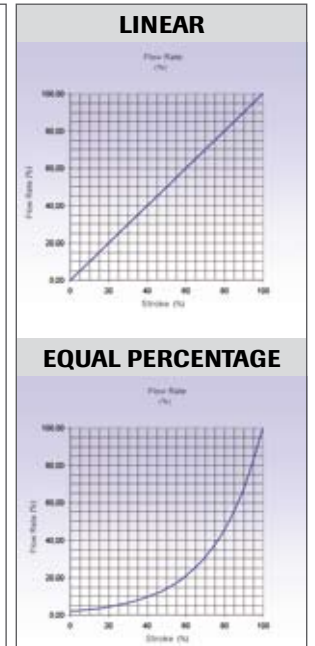

PICTURE B1

The pneumatic positioner is electronic and not programmable. It accepts the most common set-point signals (4 - 20 mA; 0 - 10 V). All calibration operations have been implemented in a sole easy automatic operation by pushing a LED lit button on top of the control box (integrated self-starter).

The pneumatic positioner can be fitted both on M&M Ø 63 and Ø 90 pneumatic actuators (ex factory, it is not a remote accessory to be built on site).

### Fluid direction is always under seat!

Control Piston actuated valves with integrated positioner are supplied by the manufacturer adjusted, tested and set up as per Customer's requests upon the purchase order. The relevant parameters must be pre-set ex factory by means of 4 deep-switches (see PICTURE C).

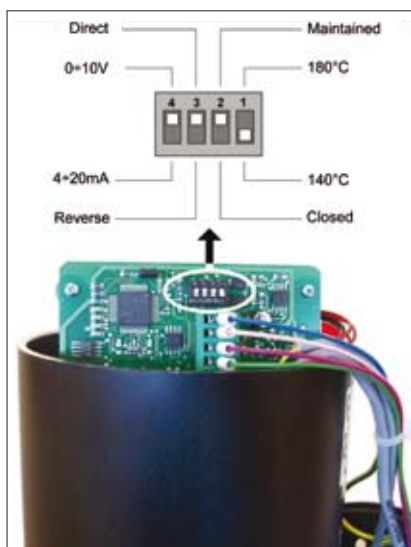

PICTURE C

- Contact No. 1 – Process temperature -**
- Contact No. 2 - Fail safe Position -**
- Contact No. 3 – Function set-up -**
- Contact No. 4 - Set point -**

Functions set-up (contact no. 3)	Set Point	Valve status
Direct (NC)	0V o 4mA	Closed
	10V o 20mA	Open 100%
Reverse (NO)	0V o 4mA	Open 100%
	10V o 20mA	Closed

## CONTROL PISTON ACTUATED VALVE WITH INTEGRATED POSITIONER DN15 UP TO DN50; STAINLESS STEEL

### TECHNICAL SPECIFICATIONS

Media: water, oil, aggressive media and steam
Media temperature: $-10^{\circ}\text{C} \div +140^{\circ}\text{C}$ (2,6 barg for steam)
High temperature version up to $180^{\circ}\text{C}$ available
Low friction stem seal (not available for PAV for high temperature version)
Ambient temperature: $-10^{\circ}\text{C} \div +60^{\circ}\text{C}$
Set point signal: $0 \div 10\text{V}$ ; $4 \div 20\text{mA}$
Electrical supply: 24V DC
MAX power consumption: 6W (0,24A)
Flow characteristics: linear or equal percentage
Protection class: IP65
Set-up point: self-adjusted valve
Pilot media: dry and filtered air mesh ( $25\ \mu\text{m}$ )
Body material: cast AISI 316L (see page 37)
Bonnet material: cast AISI 316L (see page 37)
Actuator $\varnothing$ : 63 - 90
Actuator body material: Polyamide PA6 (reinforced fiberglass 30%)
Seal material: PTFE
Positioner enclosure: anodized aluminium (black)
Fail Safe Position: "closed", "maintained"
Function: NO / NC
Electrical connections: M23 connector, 12 poles
Hysteresis: $< 1\%$ f.s.
Repeatability: $< 0,5\%$ f.s.
Minimum set-point: $< 2\%$ f.s.

### BENEFITS

Actuator housing rotation $360^{\circ}$
Valves DN32-DN50 complying with 97/23 Directive Category I
Connector rotation $360^{\circ}$ (step $90^{\circ}$ )

### OPTIONS

Connection options: screwed, flanged butt welding, socket welding and sanitary clamp
Seal material: PEEK
Body and shaped plug with hardening treatment

### TYPE: CONTROL PAV NC

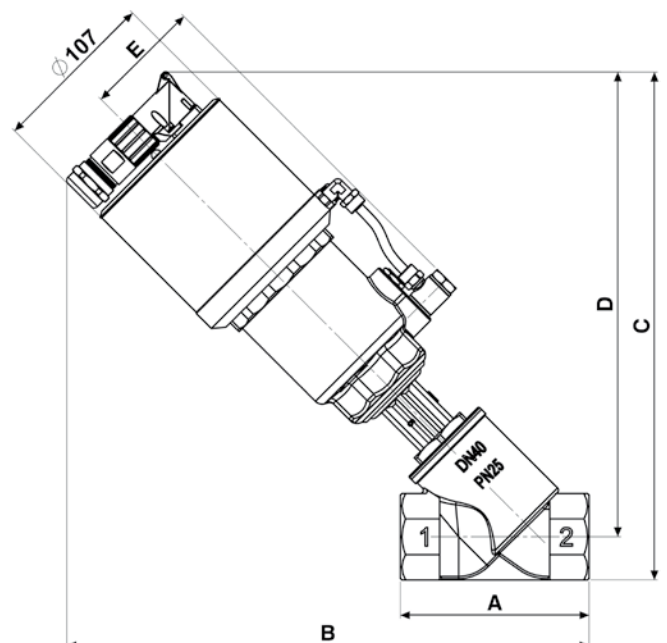

### SELECTION TABLE

DN	Max working pressure	Flow direction	Pilot pressure		Actuator $\varnothing$
			min	max	
[mm]	[barg]	[2 → 1]	[barg]	[barg]	[mm]
15	16	only under seat	4.5	8	63
20	16				
25	14	only under seat	4.5	8	90
32	12				
40	8				
50	6				



## CONTROL PISTON ACTUATED VALVE WITH INTEGRATED POSITIONER DN15 UP TO DN50; 14 STAINLESS STEEL

### DIMENSIONS & WEIGHTS

CONNECTION: GAS, NPT, WELD ENDS						
DN	Actuator Ø	A	B	C	D	Weight
[mm]	[mm]	[mm]	[mm]	[mm]	[mm]	[kg]
15	63	65	294	282,5	269	2,4
20		75	301	290	274	2,5
25	90	90	316	305	285	3,3
32		110	329	317	292,5	3,7
40		120	334	325	297,5	3,9
50		150	352	340	306,5	4,6

ALL MODELS	
Actuator Ø	E
[mm]	[mm]
63	75
90	88

CONNECTION: FLANGED EN 1092-1						
DN	Actuator Ø	A	B	C	D	Weight
[mm]	[mm]	[mm]	[mm]	[mm]	[mm]	[kg]
15	63	130	323	339,5	292	3,8
20		150	330	349,5	297	4,2
25	90	160	344	364,5	307	5,7
32		180	359	386	316	7,3
40		200	361	394	319	8,2
50		230	384	412,5	330	10,4

CONNECTION: CLAMP ISO 2852						
DN	Actuator Ø	A	B	C	D	Weight
[mm]	[mm]	[mm]	[mm]	[mm]	[mm]	[kg]
15	63	102	313	286	269	2,5
20		114	320,5	291	274	2,7
25	90	140	341	310	285	3,7
32		159	353,5	318	292,5	4,1
40		159	353,5	329,5	297,5	4,5
50		190	372	340	306,5	5,3

CONNECTION: FLANGED ANSI B 16.5						
DN	Actuator Ø	A	B	C	D	Weight
[mm]	[mm]	[mm]	[mm]	[mm]	[mm]	[kg]
15	63	139,7	321	336,5	292	3,8
20		152,4	327	346,0	297	4,2
25	90	165,1	343	361,0	307	5,7
32		184,2	357	375,0	316	7,3
40		203,2	361	382,5	319	8,2
50		228,6	384	406,0	330	10,4

CONNECTION: CLAMP ASME BPE						
DN	Actuator Ø	A	B	C	D	Weight
[mm]	[mm]	[mm]	[mm]	[mm]	[mm]	[kg]
15	63	102	313	282,5	269	2,5
20		114	320,5	290	274	2,7
25	90	140	341	310	285	3,7
32		ND	ND	ND	ND	4,1
40		159	353,5	325	297,5	4,5
50		190	372	340	306,5	5,3

### EQUI% TRIM 1:25 - FLOW RATE [l/min]

Connection	DN	Actuator Ø	% STROKE											
			5%	10%	20%	30%	40%	50%	60%	70%	80%	90%	Kvs	
-	[mm]	[mm]												
1/2"	15	63	2,1	2,6	4,2	6,4	10	16	24,5	37,5	52	62,5	75	
3/4"	20		3,9	5	9,4	15,5	24,5	37,5	56,2	80,5	102	120	145	
1"	25	90	6,5	8,5	11,5	21,5	32,5	49	76	113	150	181	213	
1 1/4"	32		12,5	16,5	27	42	62	90	135	193	240	291	330	
1 1/2"	40		22	27	44,5	66,5	99	141	211	303	358	429	496	
2"	50		20	30,5	56	87,5	135	203	290	385	467	548	605	

### LINEAR TRIM 1:25 - FLOW RATE

Connection	DN	Actuator Ø	% STROKE
			Kvs [l/min]
-	[mm]	[mm]	
1/2"	15	63	81
3/4"	20		145
1"	25	90	240
1 1/4"	32		380
1 1/2"	40		570
2"	50		655



## AVAILABLE OPTIONS

### TECHNICAL SPECIFICATIONS

The stroke regulator allows the flow to be adjusted from 0% to 100%.

Beneficial integration of position indicator.

On normally open valve it serves as manual override.

- This option must be expressly required upon order. It is available for 63/90 valve series only.

E.g. code **CG205STWR0**

### TECHNICAL SPECIFICATIONS

The travel switch detects the position of the valve (open or closed) relaying back an electrical signal.

The signal is provided by a magnetic sensor with a non-contact switch

Max switching voltage: 500 V;

Max switching current: 0,5 A;

Max switching power: 30 W/VA;

Max switching frequency: 150 Hz;

Contact actuation time: 4,5 ms;

Repeatability:  $\pm 0,3$  mm;

Temperature limits:  $- 25^{\circ} \text{C} \div + 100^{\circ} \text{C}$ ;

Protection class: IP67;

Housing material: Electroless nickel plated brass;

Plug for cable  $3 \times 0,5 \text{ mm}^2$ ;  $\varnothing 4-6 \text{ mm}$  (DIN EN 60947/5/2).

- This option must be expressly required upon order. It is available for 63/90 valve series only.

E.g. code **RCG205STWI0**

### TECHNICAL SPECIFICATIONS

The manual override allows to open or close the valve in emergency cases (lack of air pressure, electrical failure, pilot valve damaged).

For the normally open version this function is performed by the "stroke regulator".

- This option must be expressly required upon order. It is available for 63/90 valve series only.

E.g. code **CG208STZM0**

### STROKE REGULATOR



### TRAVEL SWITCH



### MANUAL OVERRIDE



## AVAILABLE OPTIONS

### FEATURES AND BENEFITS

This kit allows the installation of a position switch to detect the position of the valve by means of an electrical signal.

- Suitable for all valves
- Easy installation at user's care, even on site
- Keeps the optical view of the valve position through the upper sight dome
- Suitable for magnetic or inductive commercial switches with M12 or M8 thread upon customer's choice

How to order:

- Code 857 018 00-
- Switch and plug not included (see below)

### TECHNICAL SPECIFICATIONS

M&M offers 2 types of standard magnetic switch to be purchased in addition to the conversion kit.

Other types of switches can be outsourced directly by the customer, provided that they comply with M&M kit mounting specifications.

#### MAGNETIC SWITCHES

Technical specifications	Type A - code 680 001 00-	Type B - code 680 002 00-
Contact:	free NC, NO switch	free NC, NO switch
Repeatability:	± 0,3 mm	± 0,3 mm
Temperature limits:	- 25° C ÷ + 100° C	- 25° C ÷ + 100° C
Protection class:	IP 67	IP 67
Max switching voltage:	500 V	150 V
Max switching current:	0,5 A	1 A
Max switching power:	30 W/VA	20 W/VA
Contact actuation time:	4,5 ms	2 ms
Connection:	plug to screw clamp connection DIN IEC 60947/5/2	with cable (5 m)
Cable:	3 x 0,25 mm <sup>2</sup>	3 x 0,25 mm <sup>2</sup>

#### TYPE A: SWITCH + CONNECTOR



680 012 00-



680 001 00-

### TRAVEL SWITCH CONVERSION KIT

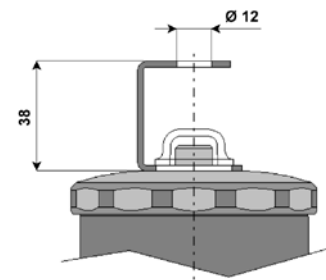

### MAGNETIC SWITCH FOR CONVERSION KIT

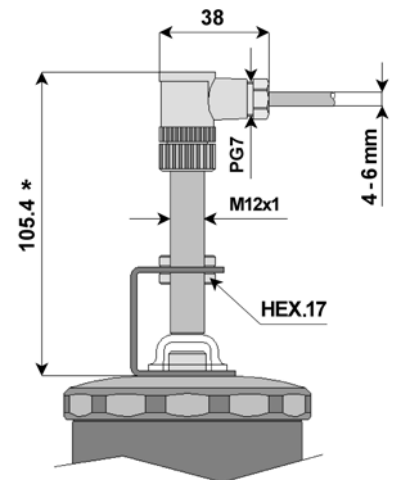

\* Type code 680 002 000 = 65 mm high

#### TYPE B: SWITCH AND CABLE (5m)



680 002 00-

## 3/2 WAY DIRECT ACTING PILOT VALVES

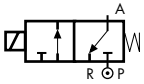

normally closed

TYPE: B356 / B326 / D326

### TECHNICAL SPECIFICATIONS

Media: water, inert gases, air		
Media temperature: -10°C ÷ +60°C		
Ambient temperature: -10°C ÷ +60°C		
Body material: brass (CW617N EN 12165) with electroless nickel plating treatment		
Operator material: stainless steel		
Seal material: FKM		
Series <b>2000</b> coils: connection to DIN 46244		
Electrical connection: fast on connection 6.3x0.8		
Series <b>7000/8000</b> coils: connection to DIN EN 175301-803 form A (ex DIN 43650-A)		
Coil power:	AC	DC
SERIE <b>2000</b>	10VA (holding) 16VA (inrush)	7W
SERIE <b>7000</b>	18VA (holding) 36VA (inrush)	14W
SERIE <b>8000</b>	12VA (holding) 24VA (inrush)	10W
Protection class: IP 65 (with connector)		



### OPTIONS

- Standard manual override/electroless nickel plating treatment
- Expressly designed to pilot M&M Piston Valves
- Valve rotation by 360° around port

### SELECTION TABLE

VALVE	Actuator Ø	Connection	DN	Flow rate Kvs	OPD			COILS	
					min	max AC	max DC	Code	[Volts/Hz]
Code	[mm]	[type]	[mm]	[l/min]	[barg]	[barg]	[barg]	Code	[Volts/Hz]
B356CVCMK	45	"push-in" pneumatic fitting for Ø 6 mm external tube	1.5	0.7	0	10	10	2250	24v DC
B326CVCMK	63		1.5	0.7	0	10	10	2200	24v 50/60Hz
D326CVEMK	90		2.0	1.3	0	10	10	2400	110v 50Hz - 120v 60Hz
								2600	200v 50Hz - 220v 60Hz
								2700	230v 50Hz - 240v 60Hz
								7250	24v DC
								7200	24v 50/60Hz
								7400	110v 50Hz - 120v 60Hz
								7600	200v 50Hz - 220v 60Hz
								7700	230v 50Hz - 240v 60Hz

Screw the pilot valve bolt into the inlet port of the piston valve actuator using a maximum torque level of 5 Nm:

- into hole **1** if the piston valve is **NORMALLY OPEN (RPG/RCG)**
- into hole **2** if the piston valve is **NORMALLY CLOSED (PG-BPG/CG-BCG)**

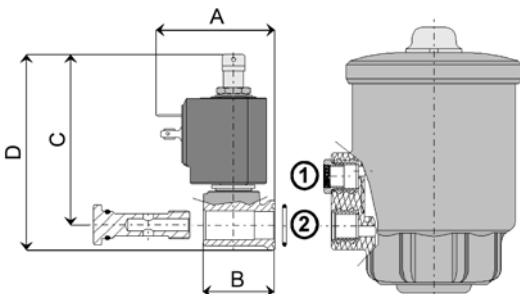

### DIMENSIONS & WEIGHTS

VALVE	A	B	C	D	Weight
Code	[mm]	[mm]	[mm]	[mm]	[kg]
B356	48	31	66.5	76.5	0.25
B326	51.5	34.5	66.3	78.3	0.25
D326	57	34.5	82.6	94.6	0.30

## 3/2 WAY DIRECT ACTING PILOT VALVES FOR USE IN POTENTIALLY EXPLOSIVE ATMOSPHERES ATEX II 2 GD

Solenoid valve equipped with coil suitable for potential explosive atmospheres protection coil class EEx m II 2GD T4

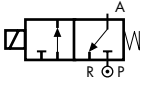

normally closed

TYPE: N326CVEK



### TECHNICAL SPECIFICATIONS

Media: water, inert gases, air
Media temperature: -10°C ÷ +60°C
Ambient temperature: -20°C ÷ +50°C
Body material: brass (CW617N EN 12165) with electroless nickel plating treatment
Operator material: stainless steel
Protection class: EEx m II 2GD T4
Seal material: FKM
Degree of protection: IP65

### OPTIONS

Coil are supplied with 3 meters power cable, wired on a non removable plug
Expressly designed to pilot M&M Piston Valves
Valve rotation by 360° around port
Manual override not available
Spare parts not available.
The valve is supplied c/w coil and plug



**WARNING!**  
Valves for potentially explosive atmosphere are available from factory only:  
**REPLACEMENT OF THE SOLENOID DOESN'T MAKE THE VALVE EXPLOSION-PROOF!**

\* A mains fuse or an equivalent means of protection (breaking value shown on table for each coil) shall be installed on the mains supply line. Absence of mains protection is a non conformity to safety standards (EC Directives 94/9/EC and 1999/92/EC) and is a possible cause of explosion.

SELECTION TABLE

VALVE	Connection	DN	Flow rate Kvs	OPD			COILS		Power	FUSES *
				min	max AC	max DC	Code	[Volts/Hz]		
Code	[type]	[mm]	[l/min]	[barg]	[barg]	[barg]				
N326CVEK	"push-in" pneumatic fitting for Ø 6 mm external tube	2.0	1.3	0	10	10	N253	24v DC	10.1W	800
							N203	24v 50/60Hz	7.2VA	800
							N403	110v 50Hz	9.1VA	200
							NK03	120v 60Hz	8.6VA	200
							N703	230v 50Hz	8.5VA	100

Screw the pilot valve bolt into the inlet port of the piston valve actuator using a maximum torque level of 5 Nm:

- into hole **1** if the piston valve is **NORMALLY OPEN (RPG/RCG)**
- into hole **2** if the piston valve is **NORMALLY CLOSED (PG-BPG/CG-BCG)**

Cable type  
H05V2V2-F 3G1  
standard length = 3 m

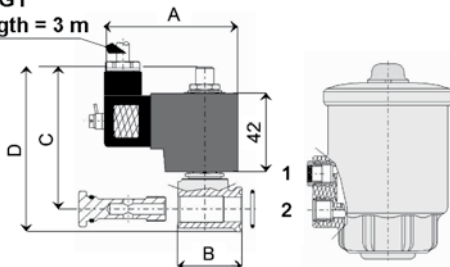

DIMENSIONS & WEIGHTS

VALVE	A	B	C	D	Weight
Code	[mm]	[mm]	[mm]	[mm]	[kg]
N326	72	34.5	74	86	0.68

## SEAL KIT FOR STAINLESS STEEL VALVES, actuator Ø 63/90

FOR VALVES WITH A PRODUCTION LOT EARLIER THAN DECEMBER 1999  
PLEASE CONTACT OUR SALES DEPARTMENT

**PG / BPG (NC)**

**RPG (NO)**

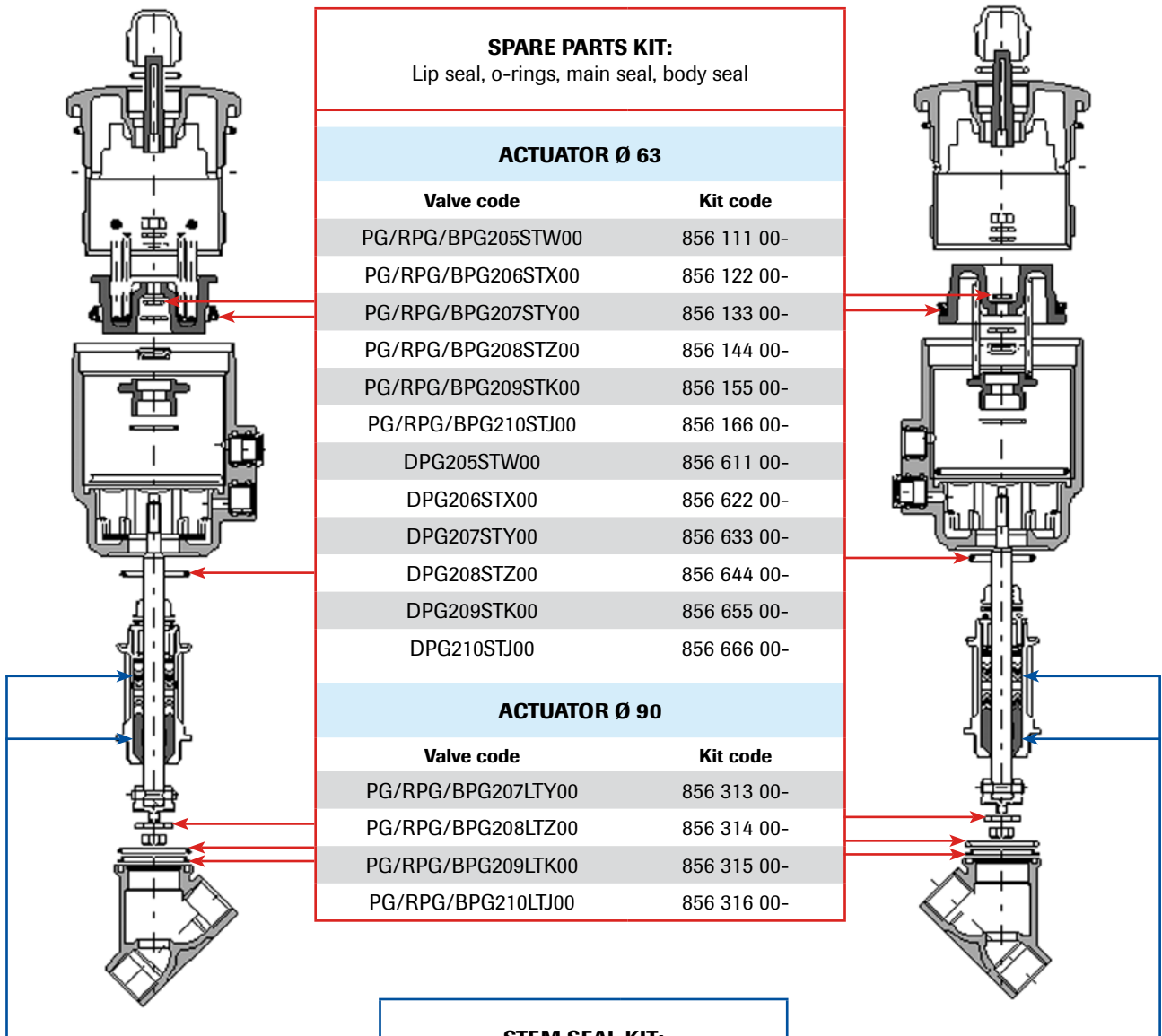

**SPARE PARTS KIT:**  
Lip seal, o-rings, main seal, body seal

ACTUATOR Ø 63	
Valve code	Kit code
PG/RPG/BPG205STW00	856 111 00-
PG/RPG/BPG206STX00	856 122 00-
PG/RPG/BPG207STY00	856 133 00-
PG/RPG/BPG208STZ00	856 144 00-
PG/RPG/BPG209STK00	856 155 00-
PG/RPG/BPG210STJ00	856 166 00-
DPG205STW00	856 611 00-
DPG206STX00	856 622 00-
DPG207STY00	856 633 00-
DPG208STZ00	856 644 00-
DPG209STK00	856 655 00-
DPG210STJ00	856 666 00-

ACTUATOR Ø 90	
Valve code	Kit code
PG/RPG/BPG207LTY00	856 313 00-
PG/RPG/BPG208LTZ00	856 314 00-
PG/RPG/BPG209LTK00	856 315 00-
PG/RPG/BPG210LTJ00	856 316 00-

**STEM SEAL KIT:**  
Upper PTFE guide and gaskets

Valve code	Kit code
ALL	856 802 00-

Any maintenance operation has to be carried out by qualified personnel following manufacturer's instructions.  
To replace seals refer to the instruction manual enclosed to the valve.

## SEAL KIT FOR STAINLESS STEEL VALVES, actuator Ø 45

**PG / BPG (NC)**

**RPG (NO)**

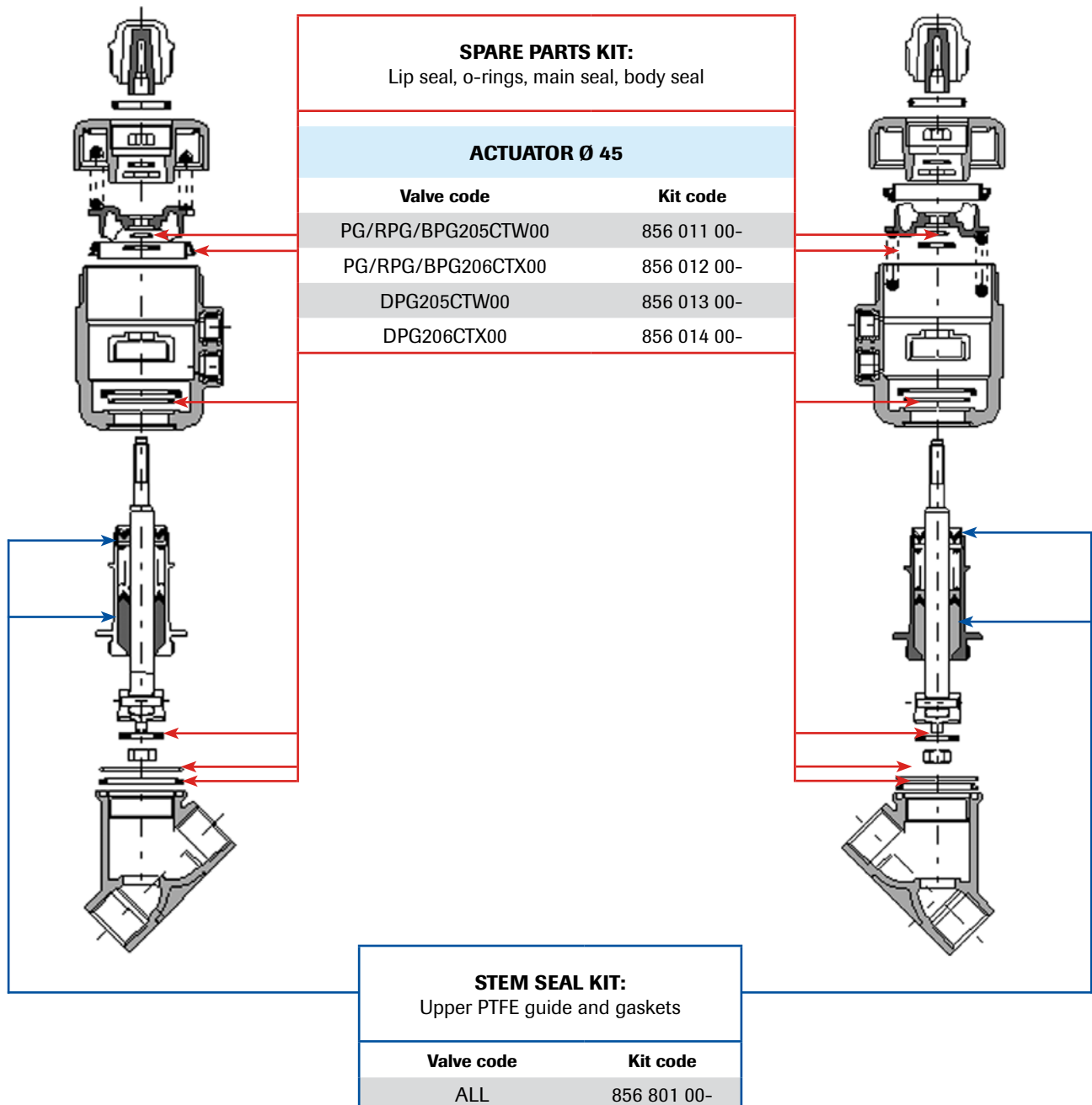

Any maintenance operation has to be carried out by qualified personnel following manufacturer's instructions.  
To replace seals refer to the instruction manual enclosed to the valve.



## SEAL KIT FOR BRONZE VALVES, actuator Ø 63/90

**CG / BCG (NC)**

**RCG (NO)**

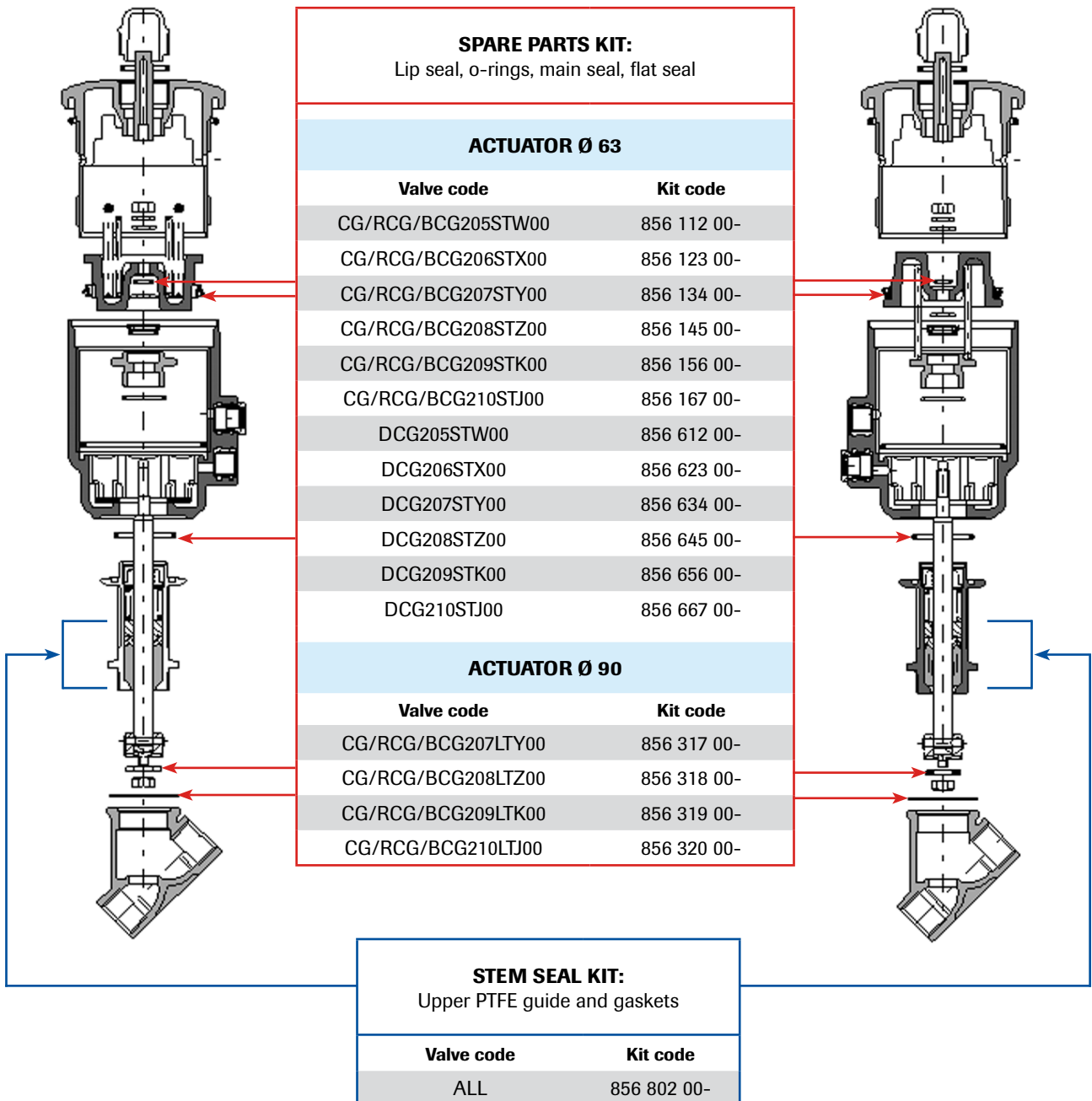

Any maintenance operation has to be carried out by qualified personnel following manufacturer's instructions.  
To replace seals refer to the instruction manual enclosed to the valve.

## SEAL KIT FOR BRONZE VALVES, actuator Ø 45

**CG / BCG (NC)**

**RCG (NO)**

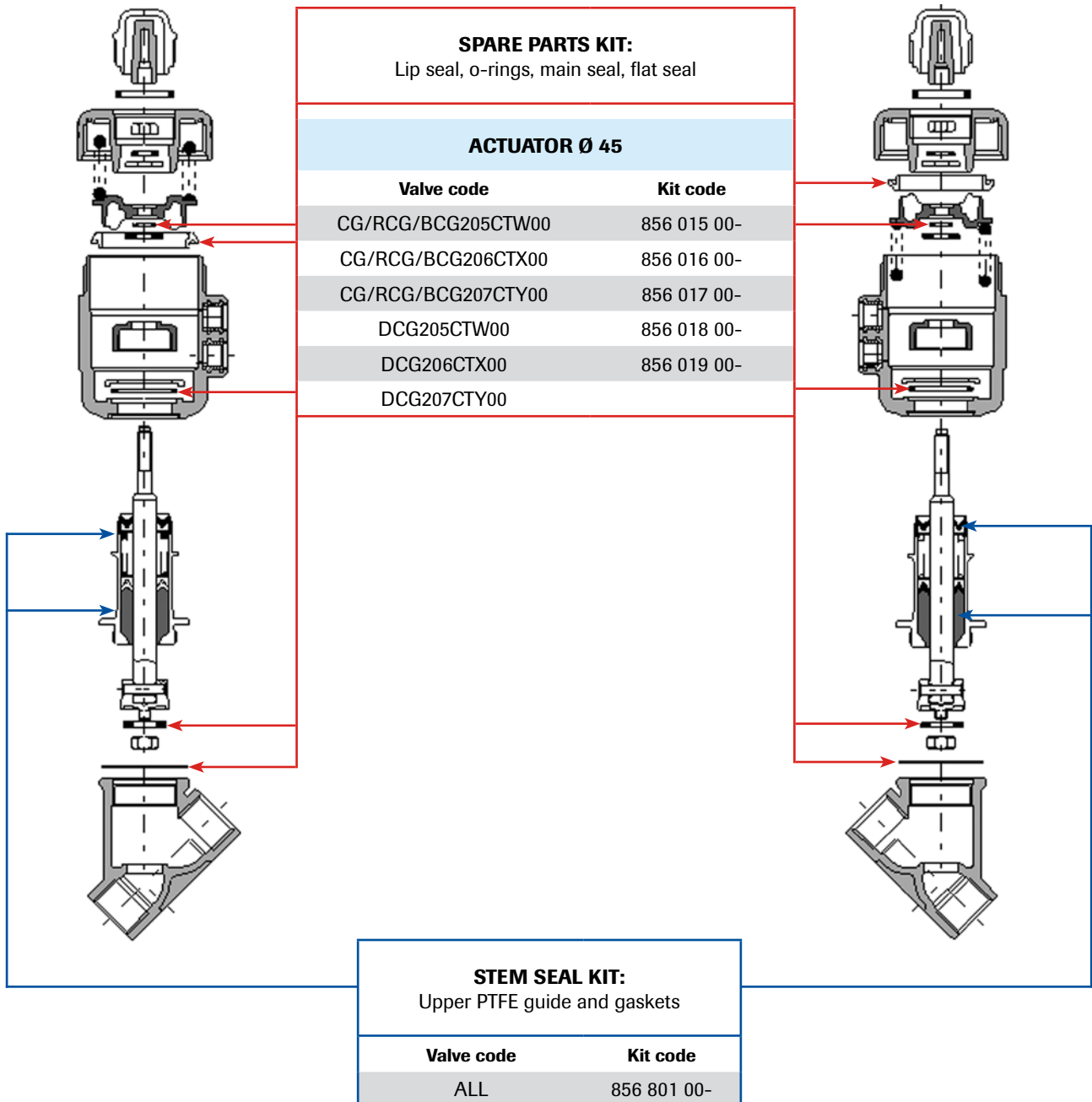

Any maintenance operation has to be carried out by qualified personnel following manufacturer's instructions.  
To replace seals refer to the instruction manual enclosed to the valve.

## VALVE SELECTION

Piston valves use an external control fluid to pilot the actuator in which a piston is directly connected to the main seal that closes onto the main orifice, thereby controlling the flow of liquids and gases.

They are highly recommended when one or more of the following conditions are given:

- ✓ Media with a high content of dirt particles
- ✓ Highly viscous media (up to 600 cST (80°E); 1 centistoke = 1 mm<sup>2</sup>/s)
- ✓ High flow volumes
- ✓ High ambient temperatures
- ✓ Environment with high humidity or hazardous locations

## M&M INTERNATIONAL PISTON VALVE VERSIONS

### NC VALVE – Flow overseat

The pilot fluid pressure to open, a spring to close.

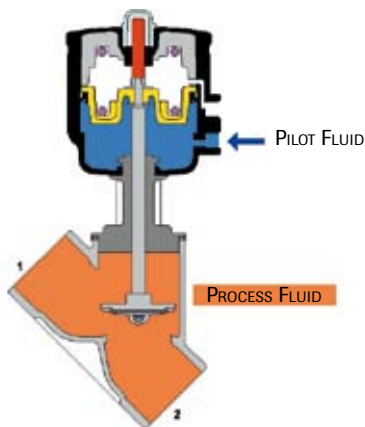

### NO VALVE – Flow underseat

The pilot fluid pressure to close, a spring to keep open.

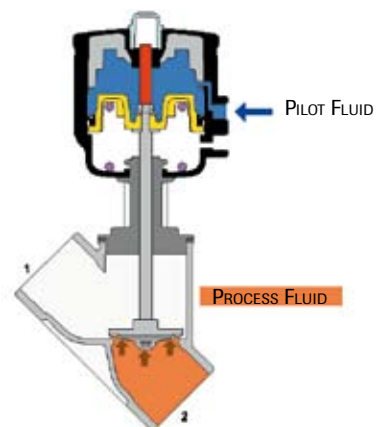

### DOUBLE ACTING VALVE Flow overseat or underseat

The pilot fluid both to open and close. No springs. This mode requires **two pilot valves**.

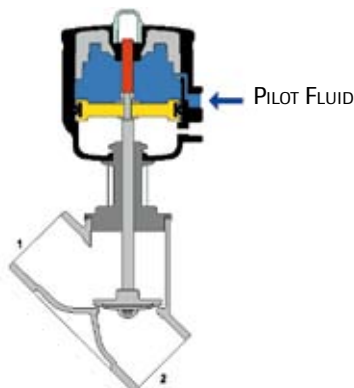

### BIDIRECTIONAL NC VALVE Flow overseat or underseat

Two springs allow use of the valve both with over seat and under seat operation.

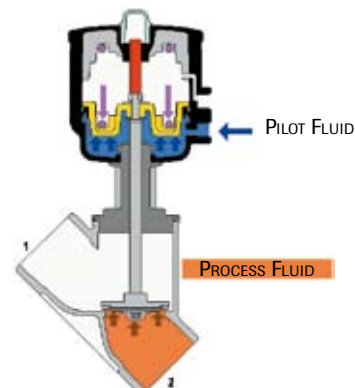

## TECHNICAL INFORMATION

M&M piston actuated valves have been upgraded over the years both by design improvements as well as by use of upgraded materials. Below we offer you some highlights about the outstanding features of M&M piston valves.

### Main seal material:

During 2004 standard PTFE has been replaced by new TFM™ 1600 alongside with some design changes concerning the main seal. TFM 1600 is a modified PTFE with a better particle fusion, which gives the following improved features against PTFE:

- ✓ Lower porosity and permeability
- ✓ Lower void content
- ✓ Higher elasticity
- ✓ Reduced deformation under load
- ✓ Better chemical resistance
- ✓ Smoother surface and improved design flexibility

### Bonnet seals:

Standard bonnet seals consist of 2 “V” shaped gaskets in FKM and of a package of 25% graphite filled PTFE gaskets.

### Stainless steel cast parts:

All our stainless steel series are fitted with bodies and bonnets in AISI 316L. These parts are cast specifically to norm ASME SA351/351M GRADE CF3M.

This type of stainless steel can be compared to the EN 1.4409 with a good approximation.

All our stainless steel cast parts bear a heat number identifying the basic material composition. Such details are stated in the casting certificate 3.1b, which can be made available to customers if required upon order and paying a small fee.

### High temperature piston valves:

M&M has developed a piston valve version to be used up to 200° C, wherever valve design accepts the applied fluid pressure of the specific application.

The main differences in materials and design that allow fluid temperature improvement are the following:

- ✓ Change of the actuator material: from standard PA6 to PA66 filled with 30% glass fibre
- ✓ All valves with DN > 25 with fixed plug design (to withstand turbulence caused by steam at high speed)
- ✓ Special design of bonnet chevrons, which are made of 25% graphite filled PTFE

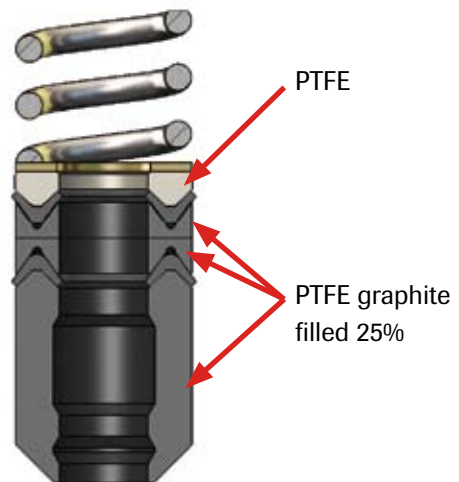

### Body Pressure (PN) chart and PED classification:

M&M valve bodies bear a PN value which is to be intended as the body design pressure in bar. We use this value as a reference to perform burst test on the bodies and bonnets upon quality control acceptance. This value has not to be considered in any relation with the applicable fluid pressure once the valve is in service. The correct fluid pressure is indicated on the valve label and it is specific for each valve size and function.

DN	Bronze PN	PED category	Stainless steel PN	PED category
15	25	Art. 3.3	40	Art. 3.3
20	25		40	Art. 3.3
25	25		40	Art. 3.3
32	25		25	Category I
40	25		25	Category I
50	16		16	Category I

## BRONZE VALVES SELECTION CHART DN15 - DN20

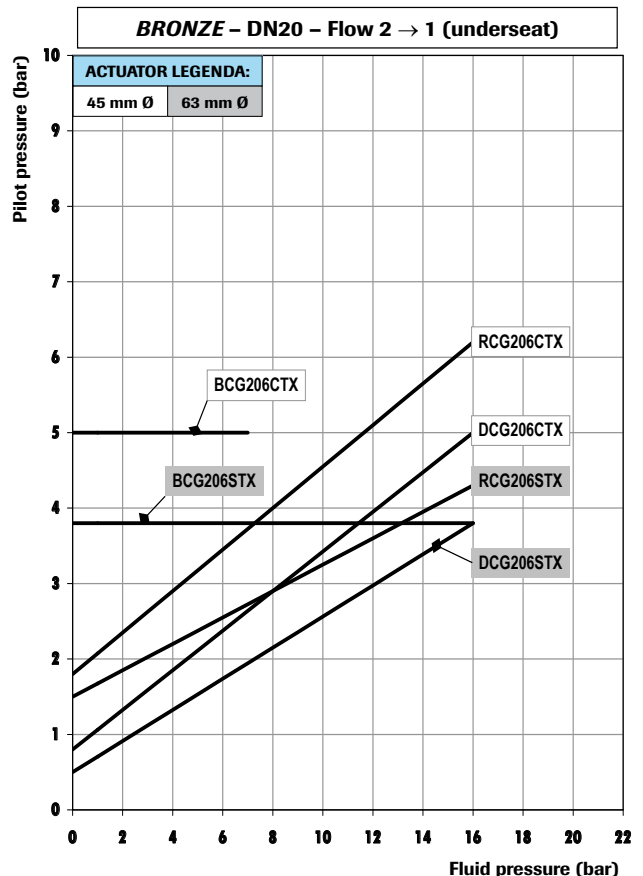
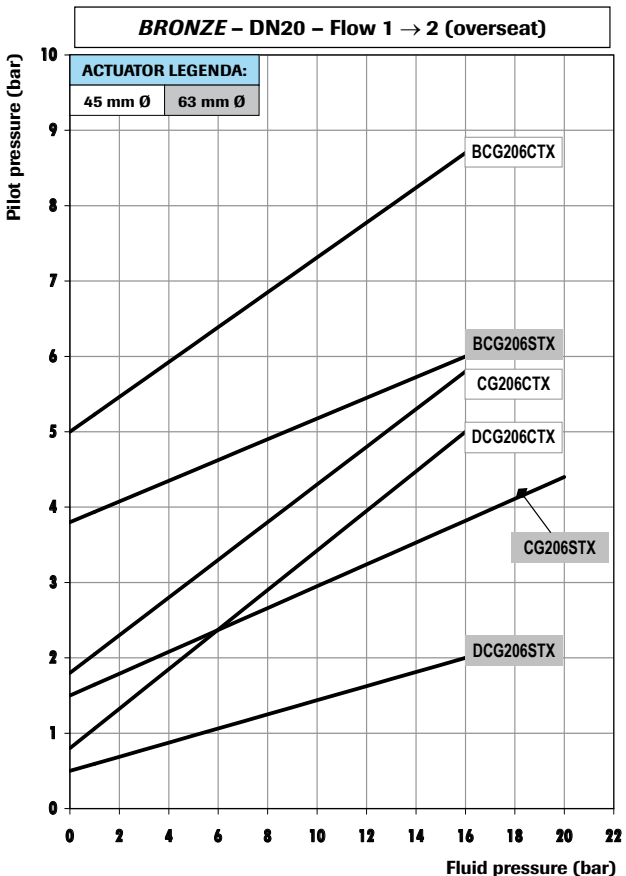
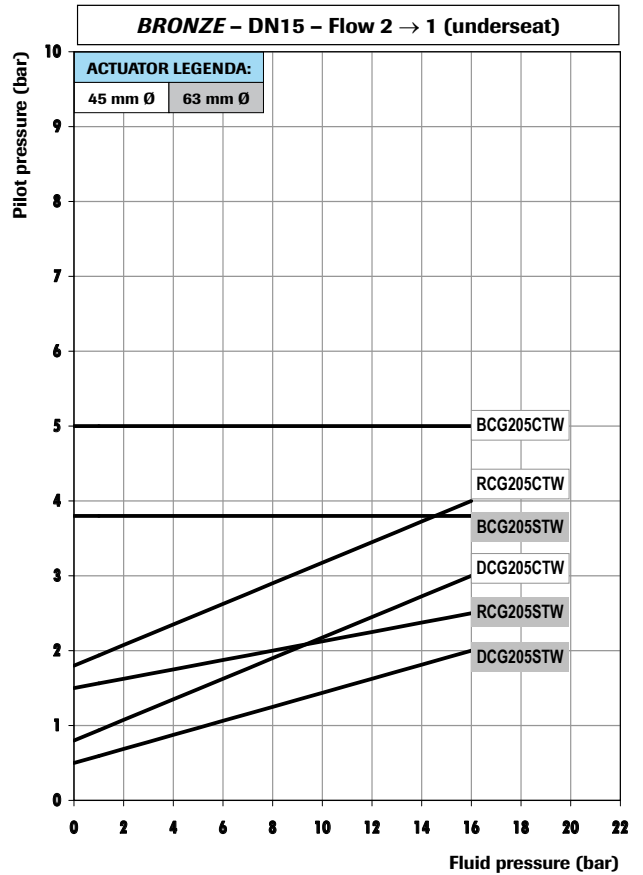
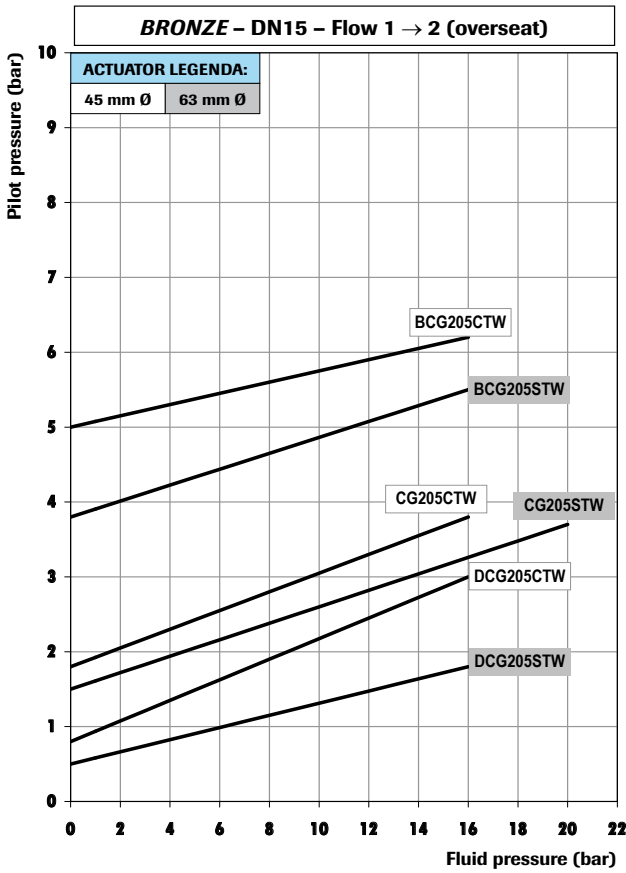

### MODEL LEGENDA

<b>CG</b> Normally closed	<b>BCG</b> Normally closed (anti-waterhammer)	<b>RCG</b> Normally open	<b>DCG</b> Double acting
------------------------------	--	-----------------------------	-----------------------------

## BRONZE VALVES SELECTION CHART DN25 - DN32

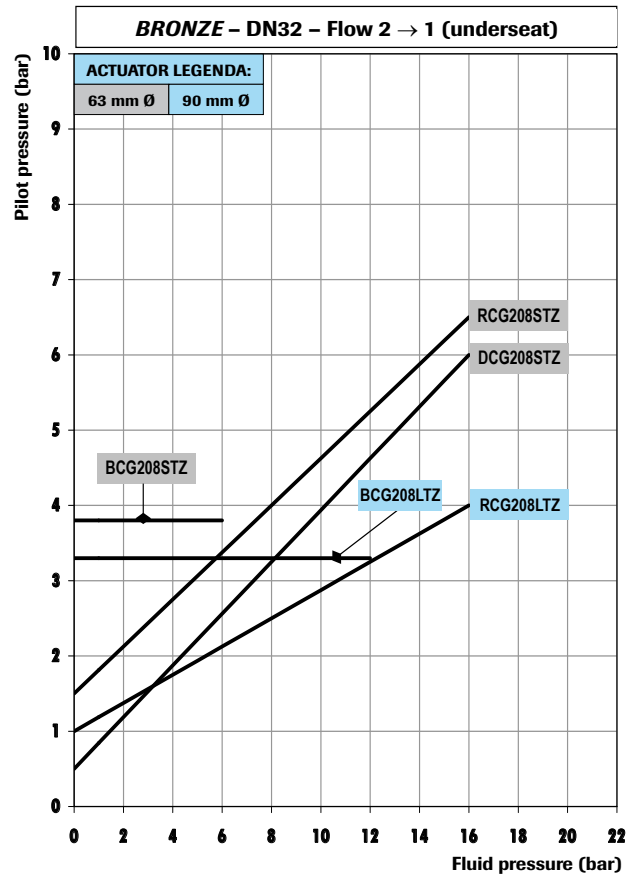
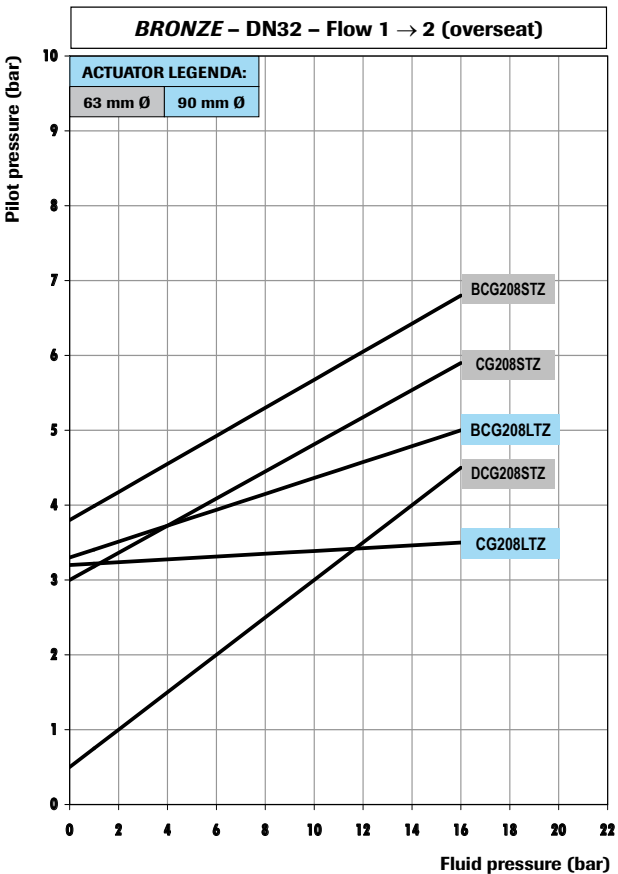
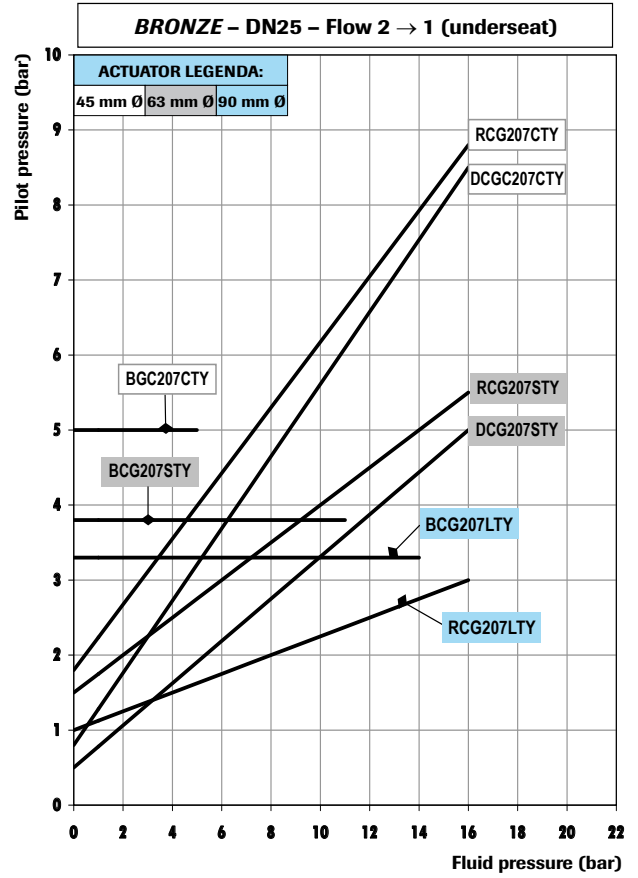
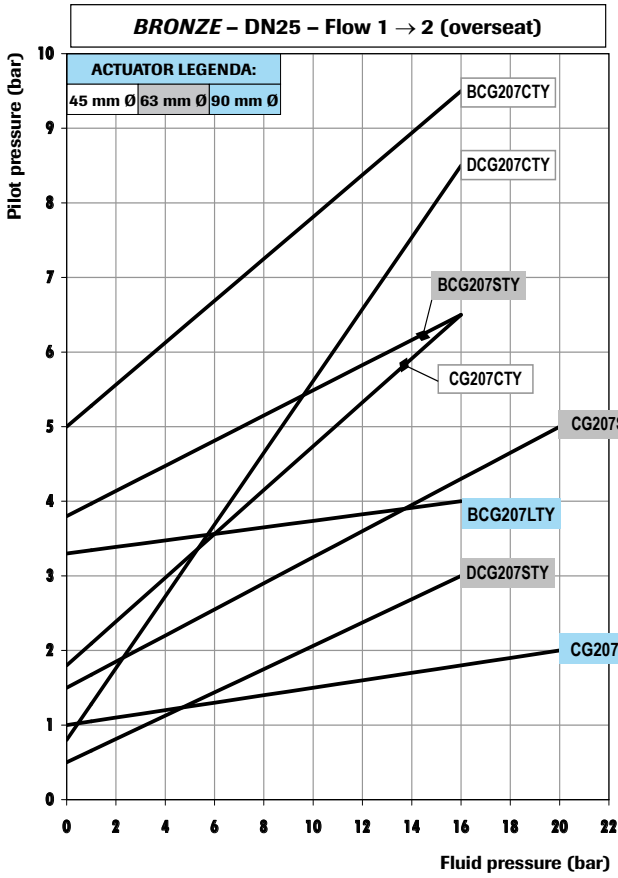

**MODEL LEGENDA**

<b>CG</b> Normally closed	<b>BCG</b> Normally closed (anti-waterhammer)	<b>RCG</b> Normally open	<b>DCG</b> Double acting
------------------------------	--	-----------------------------	-----------------------------



## BRONZE VALVES SELECTION CHART DN40 - DN50

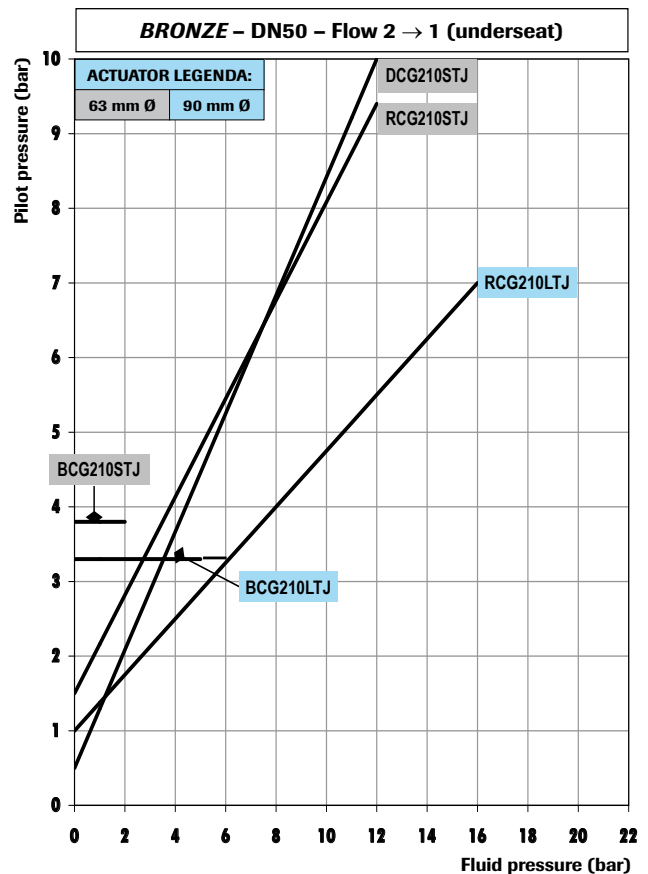
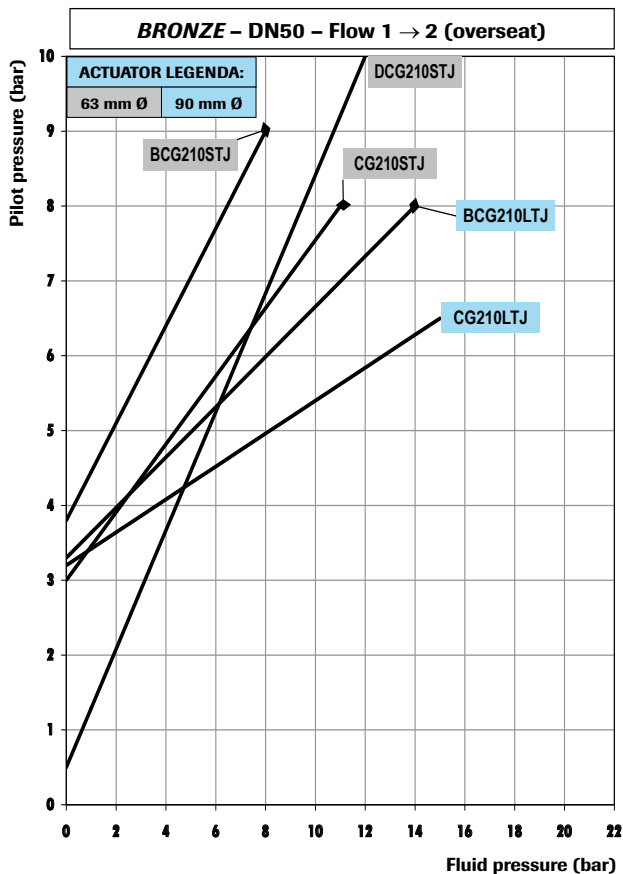
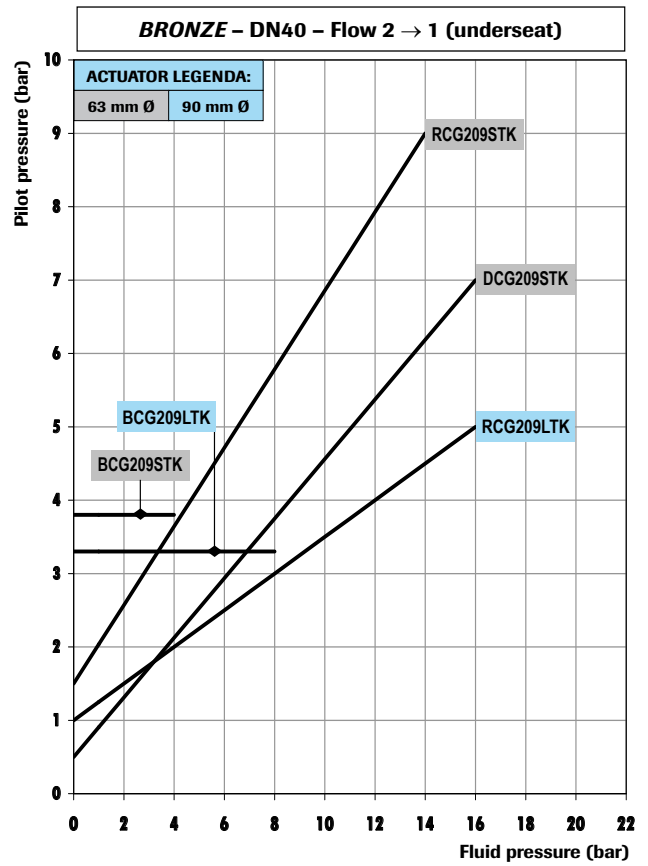
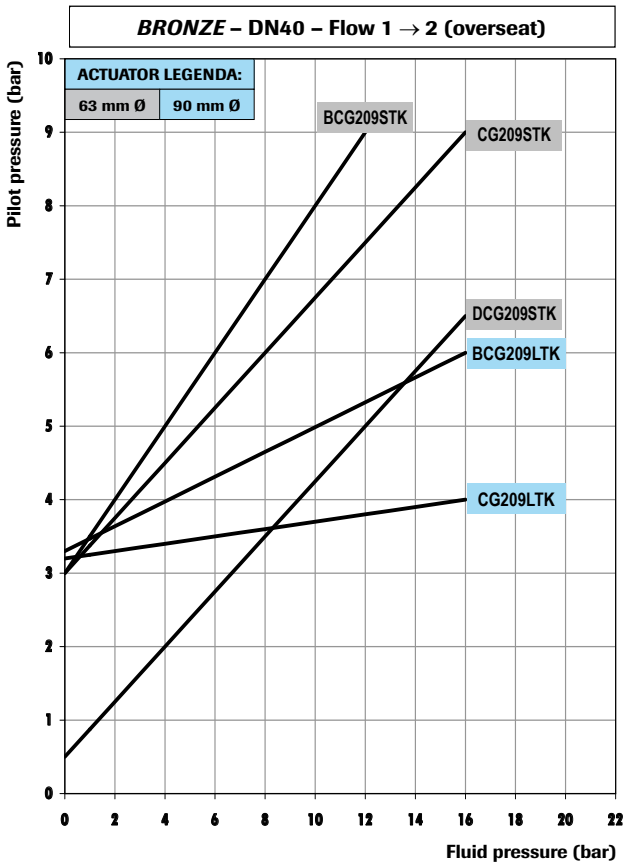

**MODEL LEGENDA**

<b>CG</b> Normally closed	<b>BCG</b> Normally closed (anti-waterhammer)	<b>RCG</b> Normally open	<b>DCG</b> Double acting
------------------------------	--	-----------------------------	-----------------------------

## STAINLESS STEEL VALVES SELECTION CHART DN15 - DN20

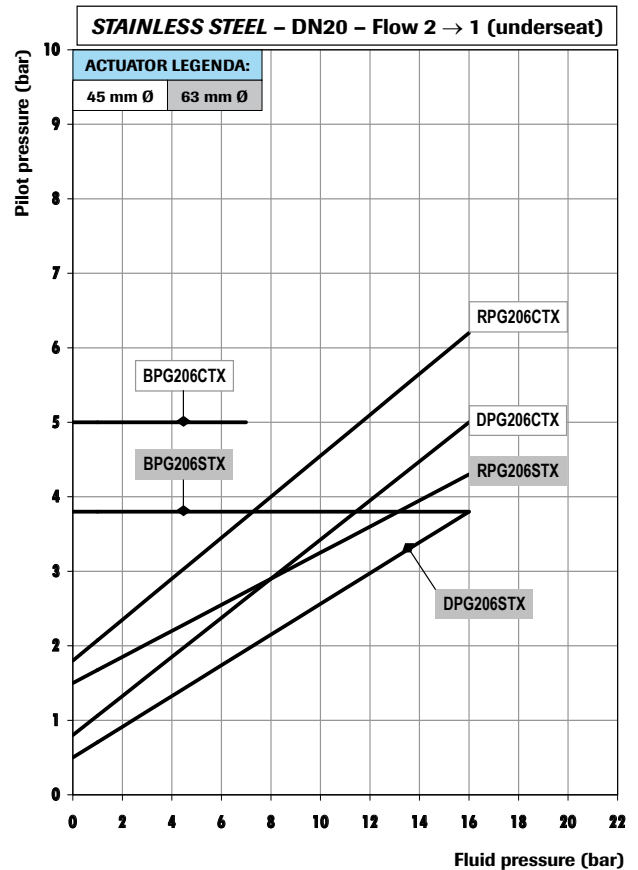
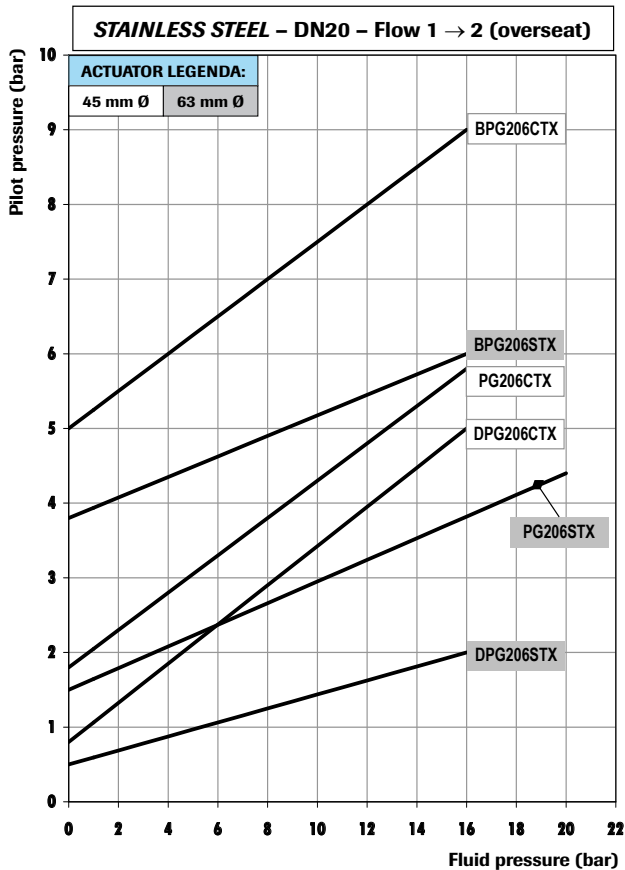
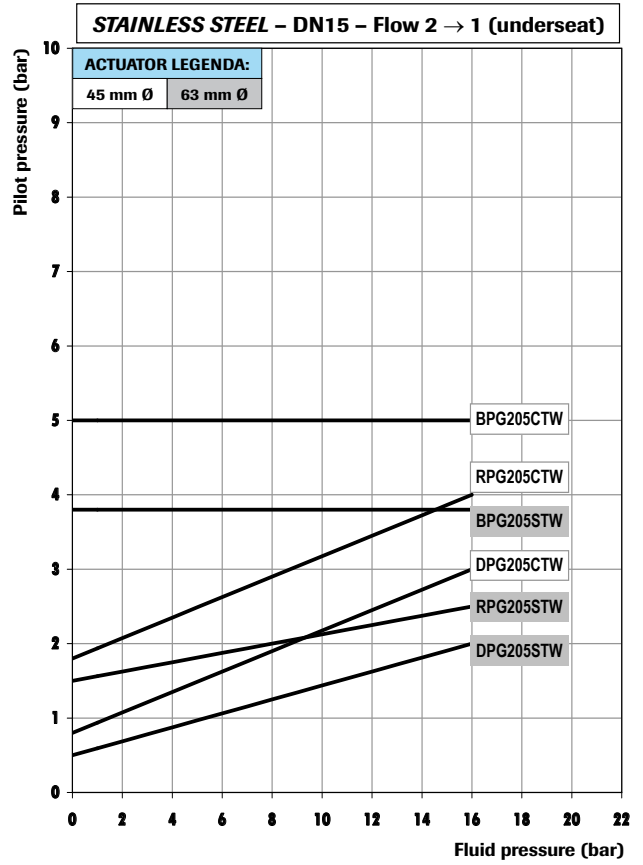
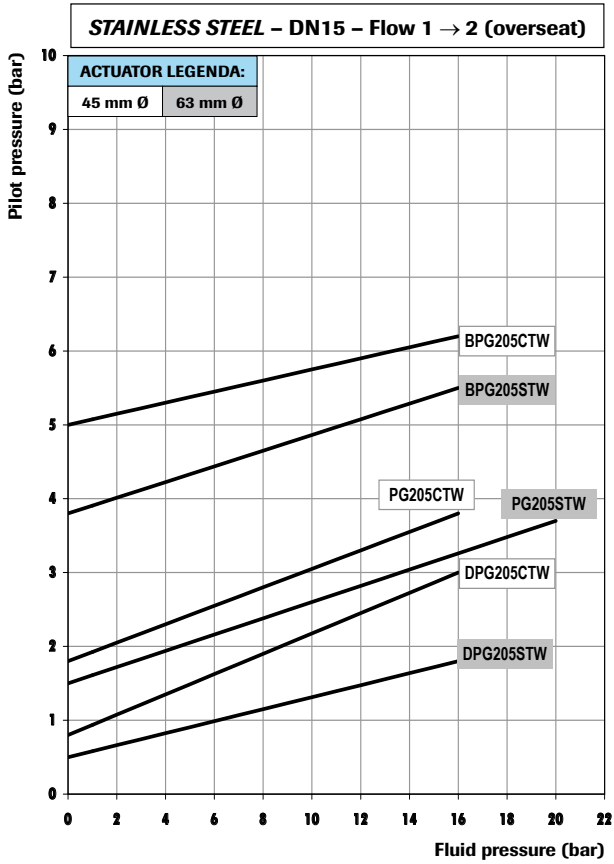

### MODEL LEGENDA

<b>PG</b> Normally closed	<b>BPG</b> Normally closed (anti-waterhammer)	<b>RPG</b> Normally open	<b>DPG</b> Double acting
------------------------------	--	-----------------------------	-----------------------------

## STAINLESS STEEL VALVES SELECTION CHART DN25 - DN32

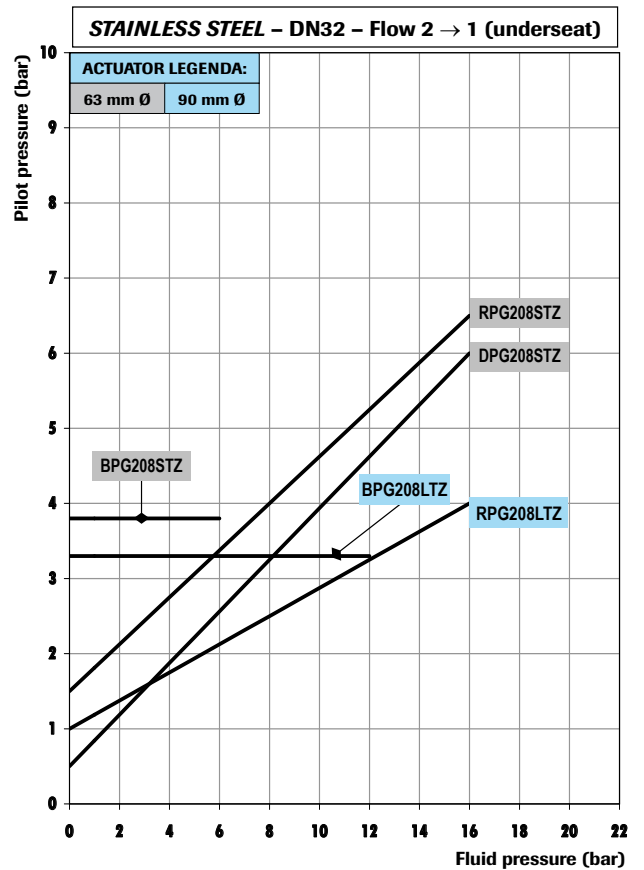
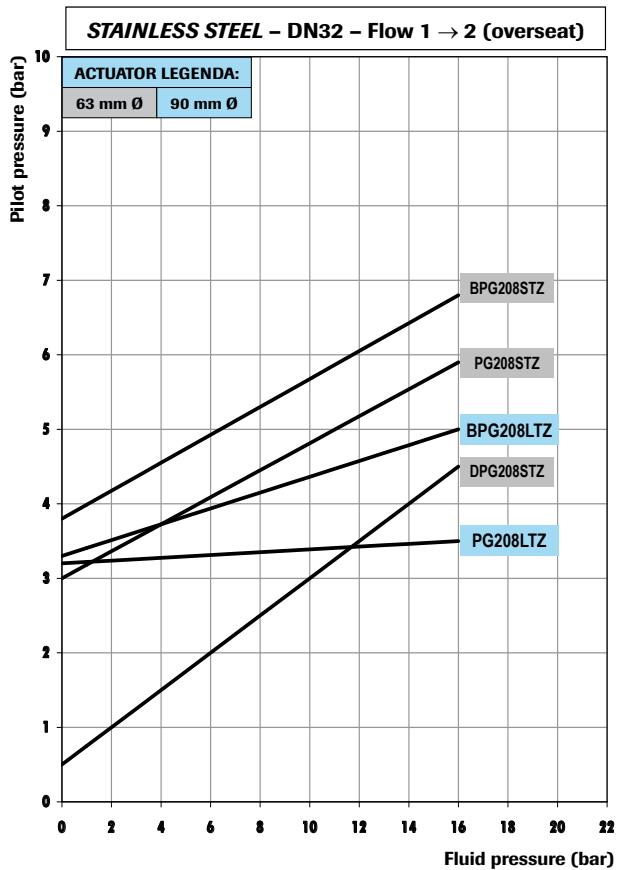
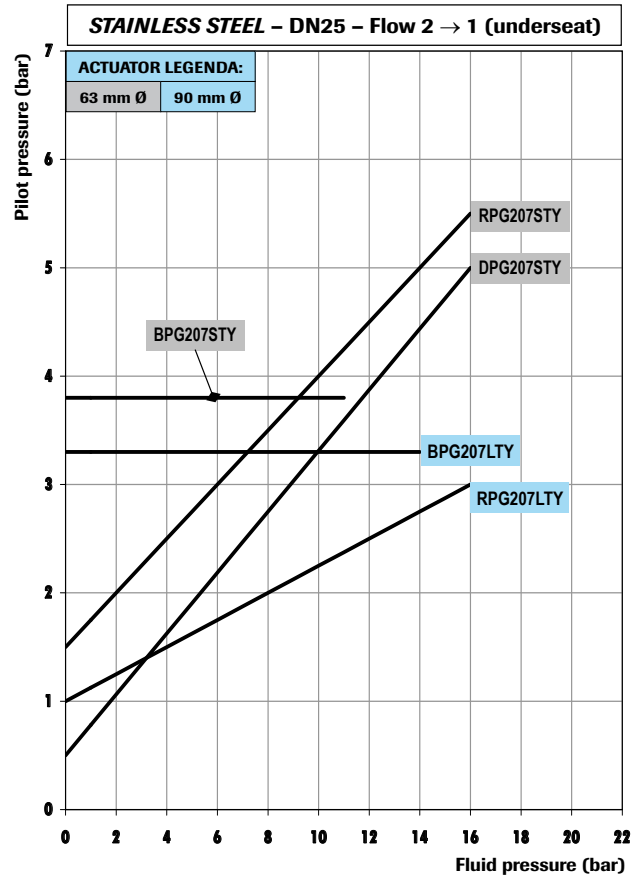
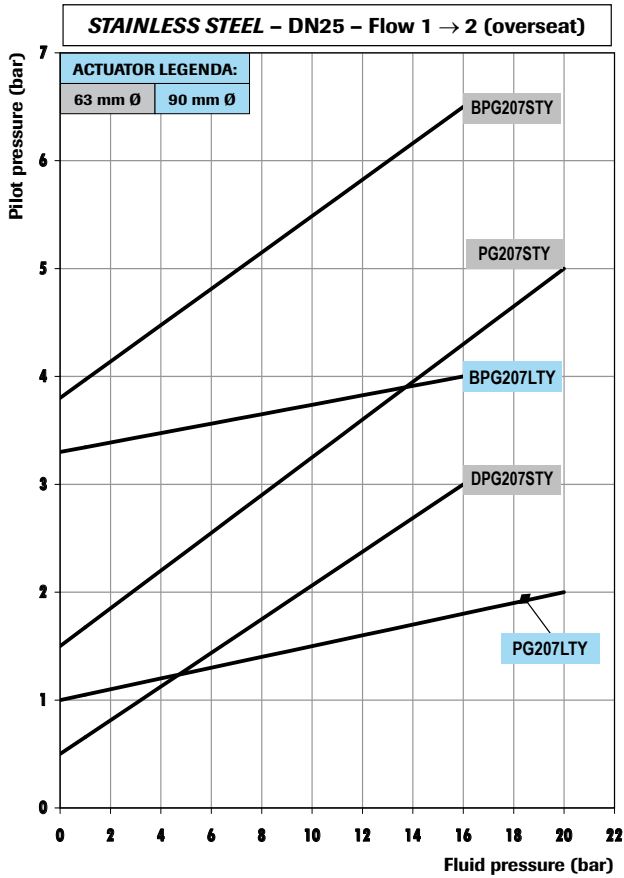

### MODEL LEGENDA

<b>PG</b> Normally closed	<b>BPG</b> Normally closed (anti-waterhammer)	<b>RPG</b> Normally open	<b>DPG</b> Double acting
------------------------------	--	-----------------------------	-----------------------------

## STAINLESS STEEL VALVES SELECTION CHART DN40 - DN50

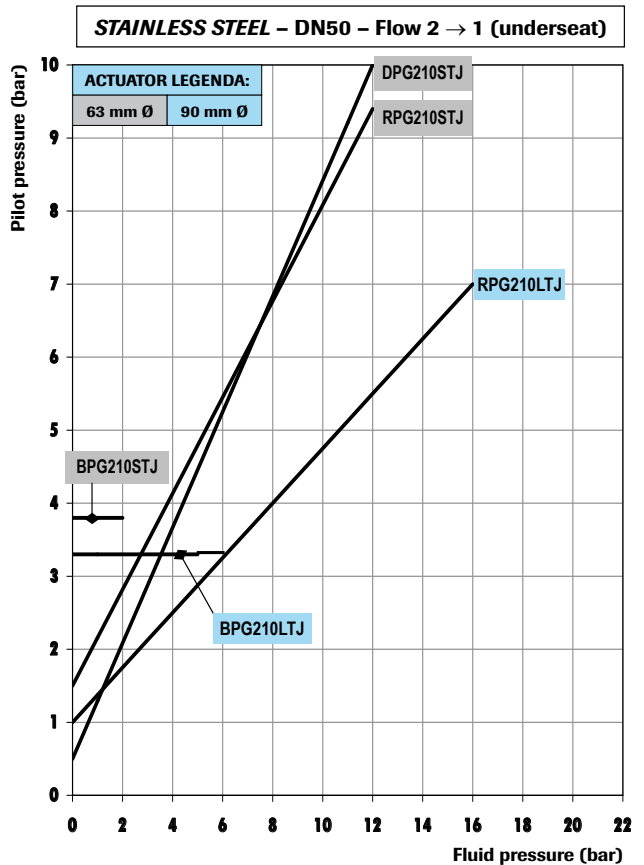
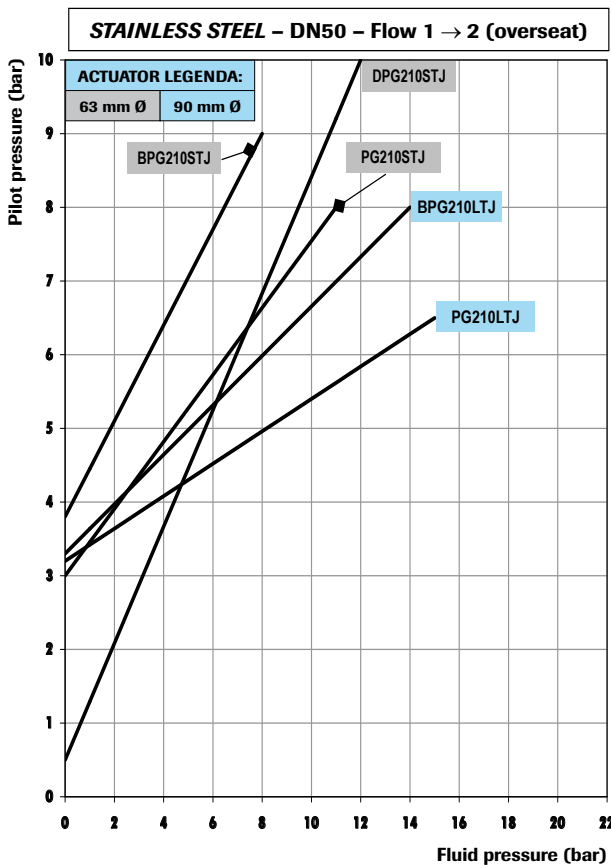
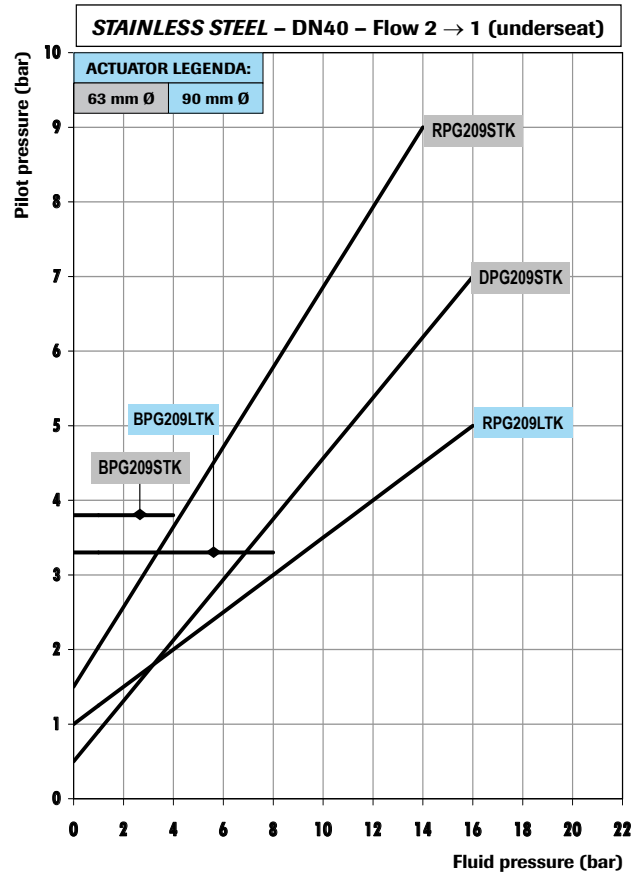
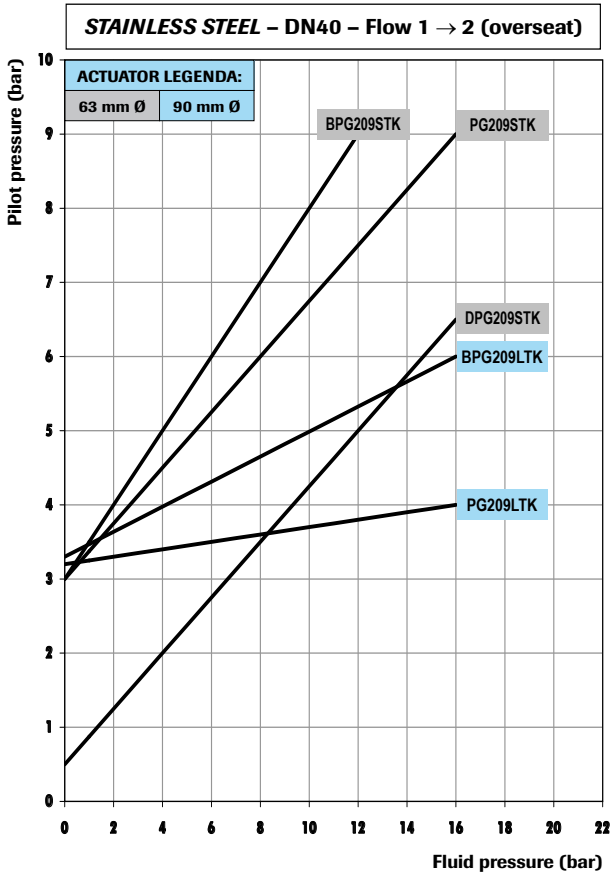

### MODEL LEGENDA

<b>PG</b> Normally closed	<b>BPG</b> Normally closed (anti-waterhammer)	<b>RPG</b> Normally open	<b>DPG</b> Double acting
------------------------------	--	-----------------------------	-----------------------------

## PAV OPENING/CLOSING TIME (sec)

NC version - Flow direction 1 → 2

DN [mm]	Actuator Ø 45 1.5 mm pilot orifice B356CVCМК		Actuator Ø 63 1.5 mm pilot orifice B326CVCМК		Actuator Ø 90 2.0 mm pilot orifice D326CVCМК	
	NC		NC		NC	
	o	c	o	c	o	c
15	0,09	0,22	0,14	0,3	—	—
20	0,09	0,22	0,2	0,3	—	—
25	—	—	0,32	0,34	0,32	0,34
32	—	—	0,34	0,38	0,36	0,4
40	—	—	0,34	0,38	0,4	0,46
50	—	—	0,36	0,38	0,4	0,46

### NOTES:

Pilot pressure: **6 bar**

Pilot media: **AIR**

Pressure in body: **0 bar**

For NO valves invert columns **o** and **c**

## DECLARATION OF CONFORMITY TO CE



## DECLARATION OF CONFORMITY CE

We, M&M International S.r.l. registered office via A. Manzoni 43 – 20121 Milano - Italy, declare under our sole responsibility that the products:

**PISTON ACTUATED VALVES type PG, PN, CG, CN, PS, PB, PW, PH, PA, PF, PD, PC (sizes DN15 to DN50)**

**and all derived versions (prefix "B", "R", "D" and "Z")**

to which this declaration relates are in conformity with the following standard(s) or other normative document(s)

**No harmonized or other technical standards are applicable to these products**

following the provisions of **97/23/EC Pressure Equipment Directive**

Series	Sizes	Requirements met	Module	Notified Body	Certificate No.
CG, CN and derived	All sizes	Art. 3.3	N/A	N/A	N/A
PG, PN, PS, PB, PW, PH, PA, PF, PD, PC and derived	DN15 to DN25	Art. 3.3	N/A	N/A	N/A
	DN32 to DN50	Category I	A (Internal Production Control)	N/A	N/A

Orio al Serio, Italy, August 2007

The General Manager

Maurizio Forno

### ATTENTION!

The attention of the purchaser, installer or user is drawn to special measures and limitations to use that must be observed when the product is used, installed or taken into service. Details of these special measures and limitations to use are available on request and are also contained in the product label and in the Installation, Maintenance and User Instructions provided together with the product.

M & M INTERNATIONAL Srl – Direzione, Uffici e Stabilimento: I – 24050 ORIO AL SERIO (BG) Via Portico, 17

Phone: ++39 / 035 / 531298 • Fax: ++39 / 035 / 531763 • Sede legale: I – 20121 MILANO (MI) – Via A. Manzoni, 43

Cap.Soc.: € 2.000.000,00 i.v. - C.F.: 0249760 016 9 P.IVA: 0322288 096 9 – Int'l VAT N. IT03222880969 • R.E.A. MILANO n. 1658695 – Iscr. Registro Imprese Milano al n. 02497600169

Società soggetta all'attività di direzione e coordinamento di Spirax-Sarco Engineering plc

# PISTON ACTUATED VALVE CODING

CODE:

1	2	3	4	5	6	7	8	9	10	11	12	13	14	15	16
---	---	---	---	---	---	---	---	---	----	----	----	----	----	----	----

FUNCTION	
-	NC normally closed
B	NC bidirectional
R	NO normally open
D	DA double acting
Z	Control / modulating

<b>WAYS</b>
2

Set-up deep switch parameters  
(only for Control Piston Valves)

SPECIAL EXECUTIONS	
O	Standard
H	High temperature (SS)
K	Nickel plated + hardening treatment
L	Low temperature (for PAV ATEX II 2GD c TX)
V	Vacuum seal (bronze)

SERIAL LETTER	
P	Stainless steel type
C	Bronze / brass type
L	Compact brass type

SPECIAL EXECUTIONS	
O	Standard
I	Travel switch
M	Manual override
R	Stroke regulator
E	Equal% Plug (only control PAV)
L	Linear Plug (only control PAV)

ORIFICE [Ø mm]	
W	15
X	20
Y	25
Z	32
K	40
J	50

CONNECTION TYPE	
A	Flange (ANSI B16.10 Klasse 150)
B	Butt weld (ISO 65 - ANSI B 36.10)
C	Clamp (ISO 2852)
D	Flange (EN 1092 Form B)
G	GAS (ISO 228)
H	Butt weld (ISO 4200)
N	NPT
S	Socket weld (ISO 65 - ANSI B 36.10)
O	Operator (w/o body)
W	Butt weld (DIN 11850)
P	Clamp connection to ASME BPE

SEAL MATERIAL	
B	NBR (only for BLG)
P	PEEK
T	PTFE
V	FKM (only for BLG)

VALVE BODY ID. CODE	
04	3/8" (only for BLG)
05	1/2"
06	3/4"
07	1"
08	1 - 1/4"
09	1 - 1/2"
10	2"

ACTUATOR TYPE	
O	Manual angle seat valve
D	Ø 32 only for BLG
C	Ø 45 Polyamide
S	Ø 63 Polyamide
L	Ø 90 Polyamide
M	Ø 63 AISI (for PAV ATEX II 2GD c TX)
G	Ø 90 AISI (for PAV ATEX II 2GD c TX)





**spirax**  
**/sarco** Engineering Group

24050 Orio al Serio (BG) - ITALY  
Via Portico 17  
tel. +39 035 531298  
fax +39 035 531773  
e-mail: [mm@mminternational.net](mailto:mm@mminternational.net)  
website: [www.mminternational.net](http://www.mminternational.net)

170 050 U90

Printed in Italy, September 2009