

Coaxial Low Pass Filter

VLFG-1000+

50Ω DC to 1000 MHz



Generic photo used for illustration purposes only
CASE STYLE: FF704

The Big Deal

- Excellent power handling, 5.5 W
- Temperature stable
- Rugged unibody construction
- Good rejection, 45 dB typical

Product Overview

VLFG-1000+ is a 50Ω low pass filter built in rugged unibody construction. Covering DC-1000 MHz bandwidth, these units offer good matching within the passband and good rejection in stopband. VLFG-1000+ offer low insertion loss, and excellent power handling capability. It handles up to 5.5W RF input power and provides a wide operating temperature range from -55°C to 125°C.

Key Features

Feature	Advantages
Low passband insertion loss	Suitable for high performance application.
5.5 W Power handling	Supports a range of system power requirements.
Connectorized package	The connectorized package is easy to interface with other devices and well suited for test setups.

Notes

- A. Performance and quality attributes and conditions not expressly stated in this specification document are intended to be excluded and do not form a part of this specification document.
B. Electrical specifications and performance data contained in this specification document are based on Mini-Circuit's applicable established test performance criteria and measurement instructions.
C. The parts covered by this specification document are subject to Mini-Circuits standard limited warranty and terms and conditions (collectively, "Standard Terms"); Purchasers of this part are entitled to the rights and benefits contained therein. For a full statement of the Standard Terms and the exclusive rights and remedies thereunder, please visit Mini-Circuits' website at www.minicircuits.com/MCLStore/terms.jsp



Low Pass Filter

VLFG-1000+

50Ω DC to 1000 MHz



Generic photo used for illustration purposes only
CASE STYLE: FF704

+RoHS Compliant

The +Suffix identifies RoHS Compliance. See our web site for RoHS Compliance methodologies and qualifications

Features

- Low loss, 0.9 dB typical
- Good rejection 45 dB typical
- Excellent power handling, 5.5 W
- Temperature stable
- Connectorized package
- Rugged unibody construction

Applications

- Harmonic Rejection
- VHF/UHF transmitters / receivers
- Lab use

Electrical Specifications at 25°C

Parameter		F#	Frequency (MHz)	Min.	Typ.	Max.	Unit
Pass Band	Insertion Loss	DC-F1	DC - 1000	—	0.9	1.8	dB
	Freq. Cut-Off	F2*	1370	—	3.0	—	dB
	Return Loss	DC-F1	DC - 1000	—	21	—	dB
Stop Band	Rejection Loss	F3-F4	1550 - 1900	20	29	—	dB
		F4-F5	1900 - 3000	35	45	—	dB
		F5-F6	3000 - 6000	30	40	—	dB
		F6-F7	6000 - 10000	—	34	—	dB

In Application where DC voltage is present at either input or output port, DC blocks are required.
* Typically, a ±5% frequency deviation from the stated value may occur on a unit-to-unit basis.

Maximum Ratings

Operating Temperature	-55°C to 125°C
Storage Temperature	-55°C to 125°C
RF Power Input*	5.5 W max. @25°C

*Passband rating, derate linearly to 1 W at 125°C ambient
Permanent damage may occur if any of these limits are exceeded.

Functional Schematic

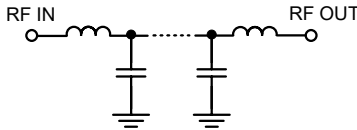

Typical Frequency Response

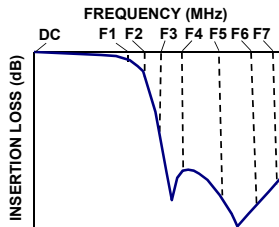

Typical Performance Data at 25°C

Frequency (MHz)	Insertion Loss (dB)	Return Loss (dB)
10	0.07	42.18
100	0.15	30.84
400	0.33	24.54
600	0.43	25.52
800	0.56	29.70
1000	0.83	20.08
1370	3.78	11.54
1490	20.25	4.08
1525	30.30	3.12
1550	36.72	2.62
1900	52.45	0.72
2000	48.94	0.61
2500	50.71	0.41
3000	46.20	0.33
5000	41.37	0.23
6000	44.55	0.29
7500	51.18	0.44
8000	45.20	0.45
9000	39.04	0.50
10000	36.47	0.55

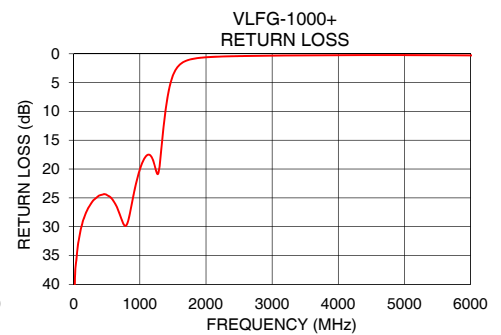
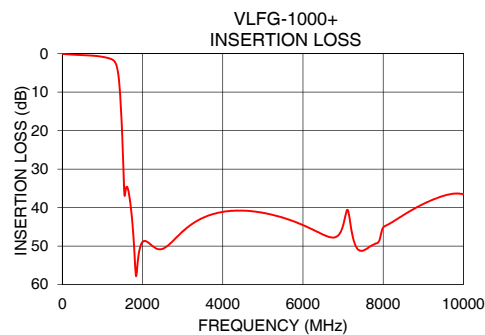
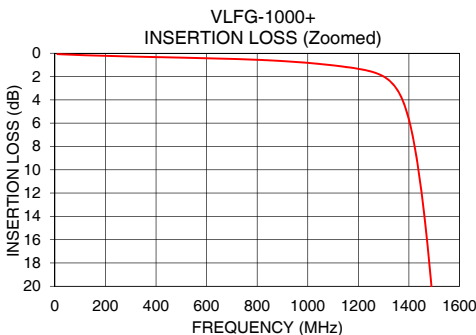

Notes

- Performance and quality attributes and conditions not expressly stated in this specification document are intended to be excluded and do not form a part of this specification document.
- Electrical specifications and performance data contained in this specification document are based on Mini-Circuit's applicable established test performance criteria and measurement instructions.
- The parts covered by this specification document are subject to Mini-Circuits standard limited warranty and terms and conditions (collectively, "Standard Terms"); Purchasers of this part are entitled to the rights and benefits contained therein. For a full statement of the Standard Terms and the exclusive rights and remedies thereunder, please visit Mini-Circuits' website at www.minicircuits.com/MCLStore/terms.jsp



Coaxial Connections

PORT - 1	SMA-Male
PORT - 2	SMA-Female

Outline Drawing

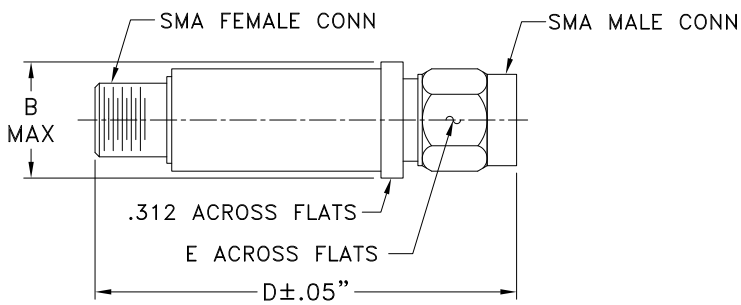

Outline Dimensions (inch)

B	D	E	wt.
.410	1.43	.312	grams
10.41	36.32	7.92	10

Note: Please refer to case style drawing for details

Notes

- A. Performance and quality attributes and conditions not expressly stated in this specification document are intended to be excluded and do not form a part of this specification document.
- B. Electrical specifications and performance data contained in this specification document are based on Mini-Circuit's applicable established test performance criteria and measurement instructions.
- C. The parts covered by this specification document are subject to Mini-Circuits standard limited warranty and terms and conditions (collectively, "Standard Terms"); Purchasers of this part are entitled to the rights and benefits contained therein. For a full statement of the Standard Terms and the exclusive rights and remedies thereunder, please visit Mini-Circuits' website at www.minicircuits.com/MCLStore/terms.jsp

