

› GN0 Series

Reverse Solid State Relays

Panel Mount – Three phase

- › For frequent start/stop/reversing operation of Three-Phase Motors
- › Interlock feature allows only start, stop and reversing operation in a safe mode
- › 25 and 50 Amps
- › LED Control
- › 2 legs control
- › Start/stop/reversing in the same package
- › Output overvoltage protection
- › Special Zero Cross (Resistive, Inductive and Capacitive loads)
- › cRUus, CE and UKCA Recognized



GN0 ⁽³⁾
(Marking label 26532004 sold separately)

Product Selection - Special Zero Cross (Resistive, Inductive and Capacitive loads)

Rated Load Current	25 A	50 A
Output Voltage	24-510 V~	24-510 V~
Control Voltage		
12-30 V~	GN025DSRL	GN050DSRL

Part number system

GN0 Reversing

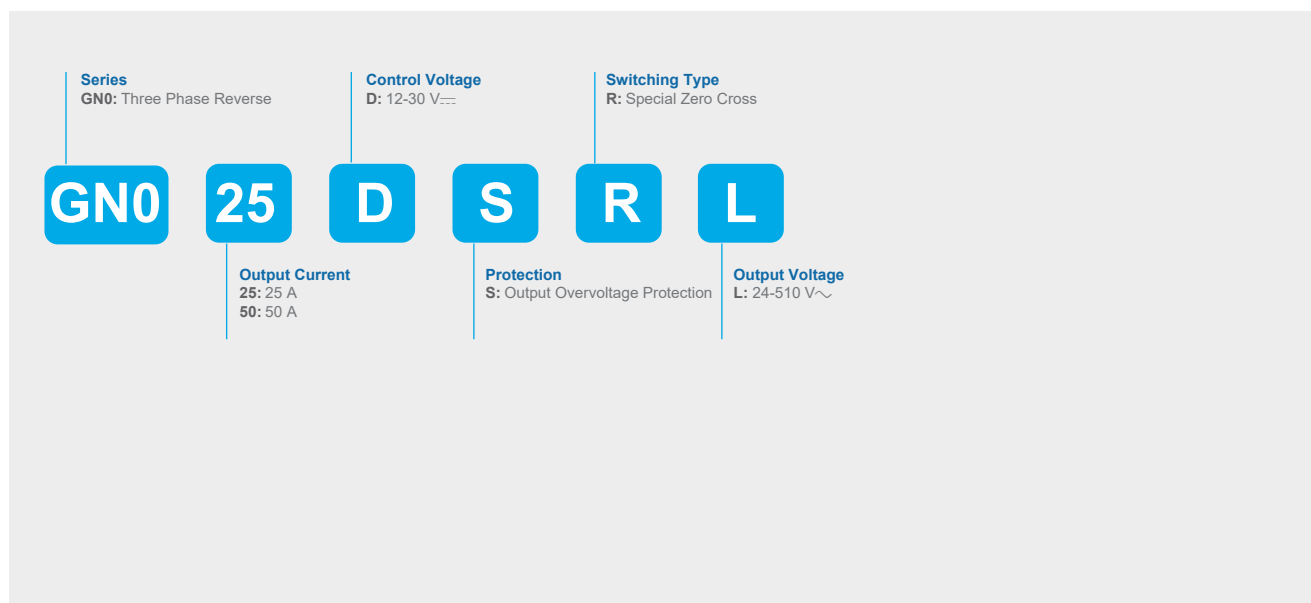

Do you need an adapted or customized solution? Contact us on www.crouzet.com

Description:

Crouzet Solid State Relays are designed to be used in almost any application, offering very long life expectancy and are easy to install, easy to use, robust and multipurpose.

For more information about Crouzet's Solid State relays, please visit www.crouzet.com.

Accessories		
Type	Description	Part-Number
Heatsink	0.9 °C/W Thermal Resistance	26532752N
Heatsink	1.2 °C/W Thermal Resistance	26532754N
Adapter	For DIN Rail	26532765N
ID Tag	Marking label 16 x 8 x 1 mm	26532004
Thermal Grease	Thermal Grease for Heatsink mounting	26532003
Screws	Screw Mounting Kit	26532002

Output Characteristics ⁽¹⁾		
Description	25 A	50 A
Operating Voltage (47-440 Hz) [Vrms]	24-510 V~	
Load Current, General Use UL508 /AC51 @ 40 °C [Arms] ⁽²⁾	3 x 25 @ 40 °C	3 x 50 @ 40 °C
Load Current, AC-53a @ 480 V~ [Arms] ⁽²⁾	3 x 5A	3 x 12A
Minimum Load Current [mArms]	5	
Transient Overvoltage [Vpk]	1600	
Maximum Surge Current (50/60 Hz (typ.@ 50 °C, 1 Cycle) [Apk]	320/_ (min) 420 (typ)	700/_ (min) 750 (typ)
Maximum I ² t for Fusing (50/60 Hz 1/2 cycle) [A ² sec]	512 (min) 880 (typ)	2450 (min) 2800 (typ)
1 second surgent current (Apeak. Ta=25 °C) 50/60 Hz	230	
Minimum Off-State dv/dt @ Maximum Rated Voltage [V/µsec]	500	
Maximum Off-State Leakage Current @ Rated Voltage [mArms]	1	
Maximum On-State Voltage Drop @ Rated Current [Vpk]		
AC-51	1.18	1.38
AC-53	1.04	1.09
Thermal Resistance Junction to Case (Rjc) [°C/W]	0.4	
Minimum Power Factor (at Maximum load)	0.5	
Minimum Heat Sink for Rated Current @ 40 °C [°C/W] ⁽²⁾	1.15 7	0.42 2.7
HP Ratings at 120V / FLC [Arms]	0.75 / 6.4	1.5 / 12
HP Ratings at 240V / FLC [Arms]	1 / 4.2	3 / 9.6
HP Ratings at 480V / FLC [Arms]	3 / 4.8	7.5 / 11

Input Characteristics ⁽¹⁾	
Description	12-30 V---
Control Voltage Range	12-30 V---
Minimum Turn-On Voltage	12 V---
Must Turn-Off Voltage	1 V---
Minimum Input Current [mA]	15 mA
Maximum Input Current [mA]	28 mA
Nominal Input Impedance [Ohms]	N/A (Control logic with interlocking)
Maximum Turn-On Time	1/2 Cycle
Maximum Turn-Off Time	1/2 Cycle

General Characteristics		
Description	25 A	50 A
Dielectric Strength Input-Output (Vrms)	4000	
Dielectric Strength Output-Case (Vrms)	4000	
Minimum Insulation Resistance (@ 500 V _{DC})	10 ⁹ Ω	
Maximum Capacitance, Input/Output	0.8 pF	
Ambient Operating Temperature Range	-40 °C to 80 °C	
Ambient Storage Temperature Range	-40 °C to 100 °C	
Housing Material	UL94 V-0	
Baseplate	Aluminium	
Terminals	Spring connector (Input) Screw (output)	
Output Screw Torque (in-lb/Nm)	18-26/2-3	
Humidity	85 % non-condensing	
Input Status Indicator	LED Forward – green LED Reverse - green	
Weight	200 g	

General Notes
(1) All parameters at 25 °C unless otherwise
(2) Heatsink required, see derating curves
(3) Control connector supplied with the product

Diagrams

Wiring

GN0 Series

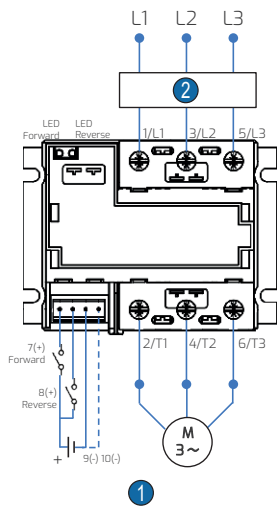

- 1 Wiring to control a 3-phase motor
- 2 Protection Equipment

Recommended Wire Size

TERMINALS	WIRE SIZE		Terminal Screw Torque (N.m)
	SOLID	STRANDED	
Input	26..12 AWG (0.2..2.5 mm ²)	26..12 AWG (0.2..2.5 mm ²)	N/A
Output	8..16 AWG (1.5..10 mm ²) 2 x 8..16 AWG (1.5..10 mm ²)	10..16 AWG (1.5..6 mm ²) 2 x 10..16 AWG (1.5..6 mm ²)	2 - 3

Diagrams

Equivalent Circuit Block

GN0 Series 4-32 V_{DC} control Thyristors - 24-510 V_{AC} - Zero Cross - GN025DSRL, GN050DSR

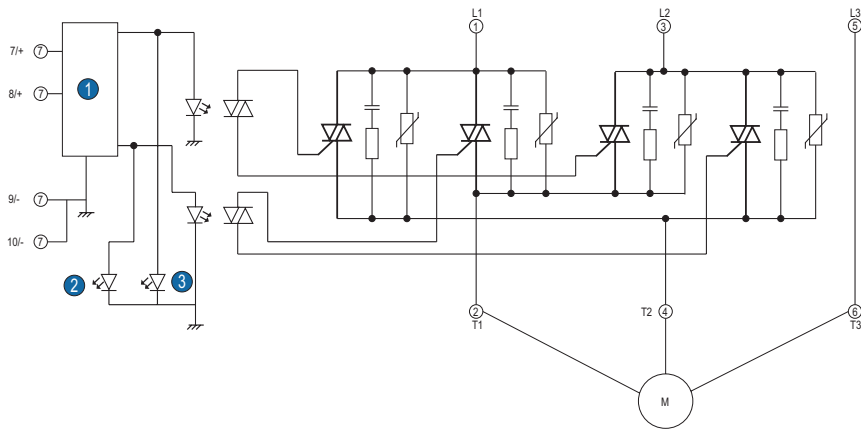

Input current vs Input Voltage

Standard Regulated DC inputs

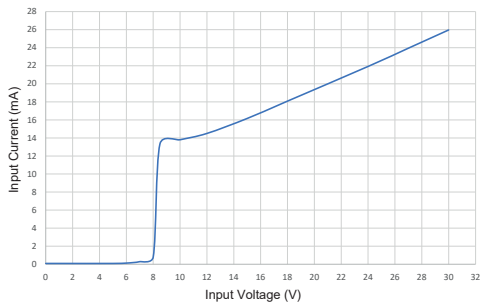

- 1 Control logic with interlocking
- 2 Forward
- 3 Reverse

Diagrams

Dimensions (mm)

GN0 Series

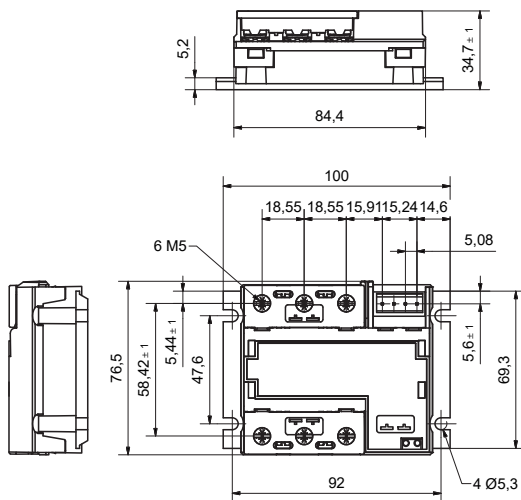

Curves

Surge Current Information

GN0 - 25 A /50 A

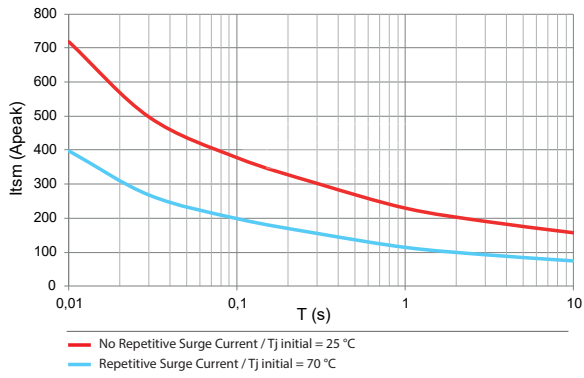

Curves

Thermal Derating Curves

GN0 - 25 A

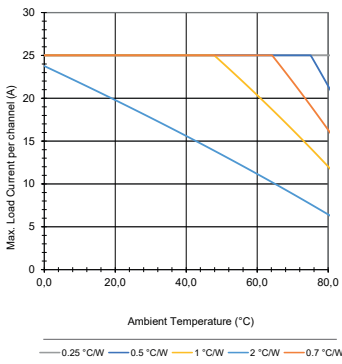

GN0 - 50 A

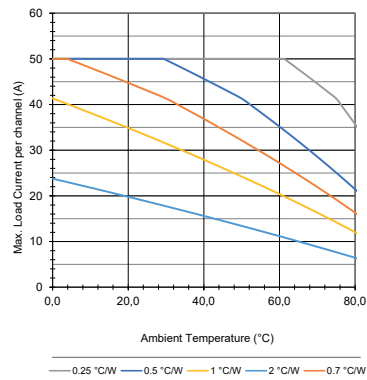

Accessories

Heatsink

0.9 °C/W Thermal Resistance - 26532752N



1.2 °C/W Thermal Resistance - 26532754N



Accessories

Others

ID Tag - **26532004**Thermal Grease for Heatsink mounting -
26532003Assembly kit 3-phases - **26532002**

Standards & Electromagnetic Compatibility Specification

IEC 60068-2-6 Vibration 35 mm / Amplitude 10-55 Hz

IEC 60068-2-27 Shock resistance 15 G / 11 ms

IEC 61000-4-2: Electrostatic Discharge immunity test 8kV air discharge Criterion A Level 3

IEC 1000-4-3: Radiated Electromagnetic Noise - Level 3

IEC 61000-4-4: Electrical fast transient/burst immunity test 1kV Line to Line Criterion B Level 3

IEC 61000-4-5: Surge immunity test 1kV Line to Line Criterion B Level 3

Standards



Warning:

The product information contained in this catalogue is given purely as information and does not constitute a representation, warranty or any form of contractual commitment. Crouzet and its subsidiaries reserve the right to modify their products without notice. It is imperative that we should be consulted over any particular use or application of our products and it is the responsibility of the buyer to establish, particularly through all the appropriate tests, that the product is suitable for the use or application. Under no circumstances will our warranty apply, nor shall we be held responsible for any application (such as any modification, addition, deletion, use in conjunction with other electrical or electronic components, circuits or assemblies, or any other unsuitable material or substance) which has not been expressly agreed by us prior to the sale of our products.