

EM-180 ON-OFF DC-MOTOR DRIVER

12/24Vdc 10A

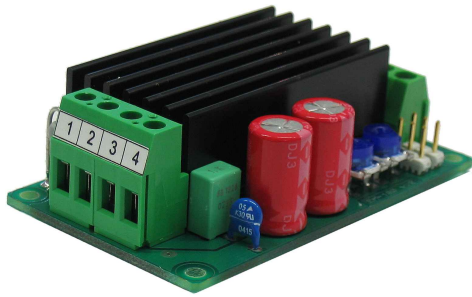

FEATURES:

- Fast change of direction
- Soft start-up, acceleration ramp
- Settable current limit
- Trip or continuous current limit
- High efficiency
- Dynamic braking
- High momentary load capacity
- Rail base fittable
- Freewheel option
- Two control modes

EM-180 is developed for controlled ON-OFF driving and direction change of a DC-motor with brushes. Driver has advanced current limit features. It limits the motor current in start-up and jam-situations and that way protects the motor and mechanics from over torque. Driver has also an error output to indicate error / over current situations.

The acceleration ramp time for start-up is adjustable to suit each application. In other word the motor voltage is slowly risen to give a smooth start-up. As the control is set off, the motor is dynamically braked with so called short-circuit braking. The motor poles are connected together. The reverse and forward commands can be set with positive or negative control. The freewheel command sets motor run free. Freewheel overrides forward and backwards commands.

The current protection is double acting. First there is a continuous and adjustable current limit which decreases the motor voltage if the current exceeds the adjusted value. Second there is settable trip feature that cuts the motor voltage if the current limit value is exceeded (after trip delay 2ms). After trip the motor starts only to the opposite direction. Additionally the driver doubles the adjusted current value for 0.3 seconds in start-up to ensure sufficient power to overcome the start-up friction. Error output indicates the activation of the current limit.

TECHNICAL DATA

Supply	12-32Vdc
Over voltage protection	40V
Idle current	app. 30mA
Driving current	10A continuous 15A 50/50%
Current limit	1...15A 2...30A in start-up
Current trip delay	n. 2ms
Start delay	5ms
Stop delay	5ms
Direction change time	n. 20ms
Voltage loss	0.5V (Im=10A)
Operating frequency	500Hz
Ramp	0.10, 20, 40, 80 150ms 0.25, 0.5, 1s
Digital inputs	"off" @ Uin 4 -30V or open "on" @ Uin 0-1V
Error output	max 30V 50mA
Measures	43x73x35mm
Weight	app. 80g

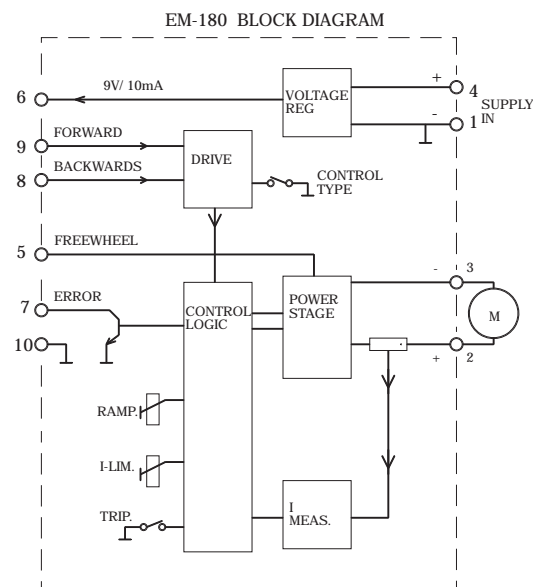

EM-180 OPERATING INSTRUCTIONS

Supply should be filtered 12-32Vdc,
 max. ripple <30% on full load.
 ATT. Wrong supply polarity can damage the driver.
 ATT. Driver has no fuse in it.

Choose the current limit mode: continuous/tripping
 Trip jumper: on=tripping limit, off=continuous limit

Choose control mode (forward / backwards)
 pos = PNP positive control
 neg = NPN negative control

Choose the ramp time

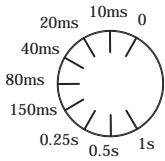

Choose the current limit value / Amps.

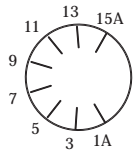

ATTENTION

- The current limit values can be affected by the used motor.
- In start-up the current limit value is doubled (for 0.3s).

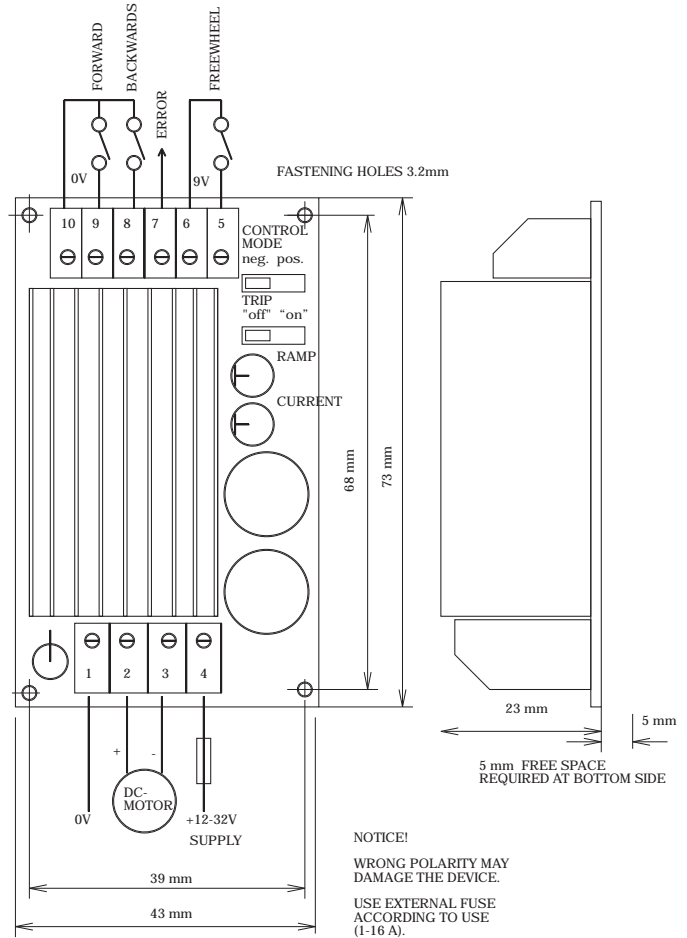

NOTICE!
 WRONG POLARITY MAY
 DAMAGE THE DEVICE.
 USE EXTERNAL FUSE
 ACCORDING TO USE
 (1-16 A).

OPERATIONAL EXAMPLE: tripping current limit

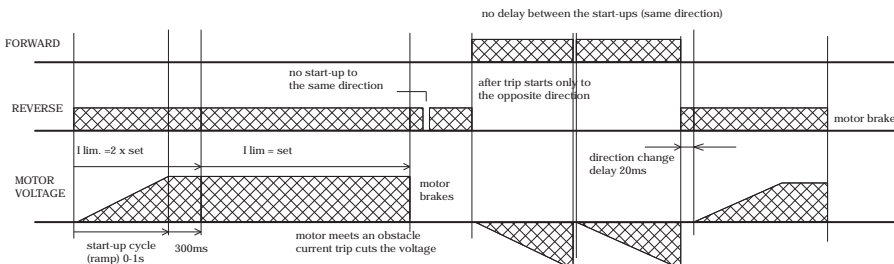

OPERATION EXAMPLE: continuous current limit

