

MATERIAL NO.	ENGINEERING NO.	SIZE	A REF.	B ± .010
834219014	83421-9014	9	19.93 (.785)	14.35 (.565)
834229014	83422-9014	15	23.75(.935)	18.16 (.715)
834249014	83424-9014	25	30.10 (1.185)	24.51 (.965)

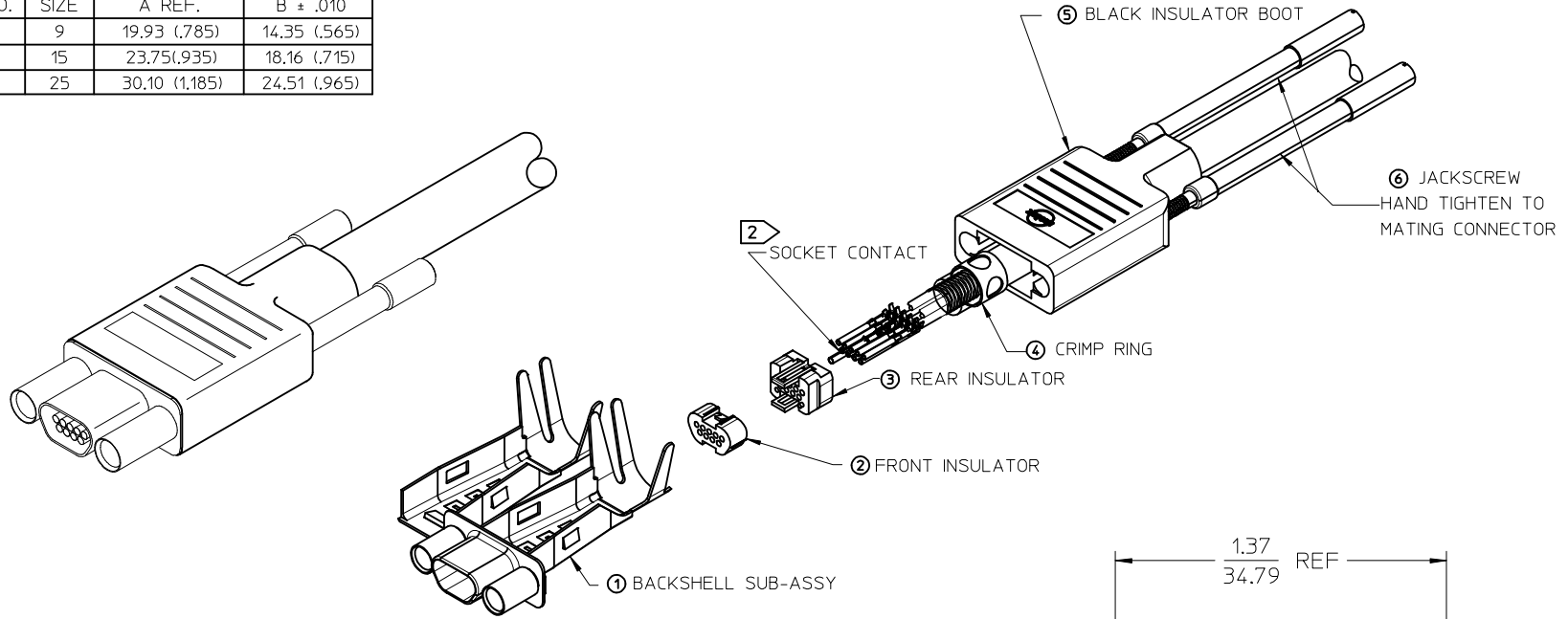

ITEM	ITEM	DESCRIPTION
7	1	ASSEMBLY INSTRUCTIONS NOT SHOWN
6	2	2-56 JACKSCREW UNDIPPED
5	1	RUBBER BOOT MICRO-D
4	1	CRIMP RING MICRO-D
3	1	REAR INSULATOR
2	1	FRONT INSULATOR
1	1	BACKSHELL SUB-ASSY, MICRO-D SIZE I5

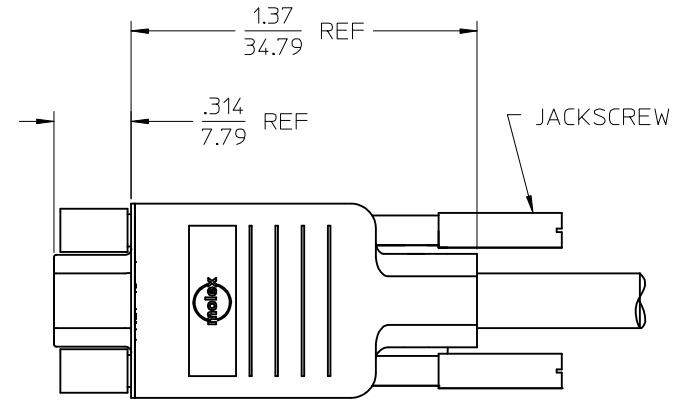
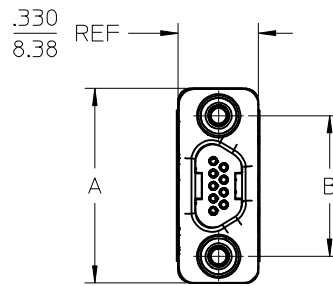

3. ROHS COMPLIANT

CONTACTS SOLD SEPARATELY. ORDER BY:  
 P/N 830009502 (2500 CONTACT REEL)  
 P/N 830009503 (50000 CONTACT REEL)  
 P/N 830000083 (LOOSE CONTACTS)

1. REFER TO PS-83421-001 FOR PRODUCT SPECIFICATION

NOTES: UNLESS OTHERWISE SPECIFIED

ADDED LAYOUT VIEW EC NO: IPG2014-0111 DR:MINIBARDEN CHKD: APPR:BMOODMAN 2013/07/16 2013/07/25	QUALITY SYMBOLS	GENERAL TOLERANCES (UNLESS SPECIFIED)	DIMENSION STYLE	SCALE	DESIGN UNITS	THIRD ANGLE PROJECTION
	▽=0 ▽=0	mm INCH 4 PLACES ± --- ± --- 3 PLACES ± --- ± --- 2 PLACES ± --- ± --- 1 PLACE ± --- ± --- 0 PLACE ± --- ± ---	IN/MM	2:1	INCH	
		ANGULAR ±1/2° DRAFT WHERE APPLICABLE MUST REMAIN WITHIN DIMENSIONS	DRAWN BY DATE URBACH 99/09/03 CHECKED BY DATE HEB 02/01/31 APPROVED BY DATE RWD 02/01/31	TITLE	CONNCTOR KIT, RECEPTACLE, W/2-56 JACKSCREWS <b>molex</b>	
			MATERIAL NO.	SEE CHART	DOCUMENT NO.	SD-83421-002

THIS DRAWING CONTAINS INFORMATION THAT IS PROPRIETARY TO MOLEX INCORPORATED AND SHOULD NOT BE USED WITHOUT WRITTEN PERMISSION

10	9	8	7	6	5	4	3	2	1
MATERIAL NUMBER	ENGINEERING NUMBER								
834219101	83421-9101								

### CONNECTOR ASSEMBLY INSTRUCTIONS

1 SLIDE INSULATOR BOOT OVER CABLE.

2 SLIDE CRIMP RING OVER CABLE.  
BRAIDED SHIELD FOLDS BACK OVER CRIMP RING.

3 STRIP CABLE PER STRIPPING INSTRUCTIONS. (SH 1&2)

4 CRIMP CONTACTS PER CRIMP INSTRUCTIONS. (SH2)  
SEE 638522000 & 638622000 FOR APPLICATOR, TERMINATOR DIE AND CRIMP SPEC..  
SEE 638114800 FOR HAND TOOL AND CRIMP SPEC.

5 INSERT CONTACTS INTO BACK OF REAR INSULATOR USING NEEDLE NOSE PLIERS WITH A 3/64in/1MM TIP  
(SPECIAL CARE MUST BE TAKEN NOT TO DAMAGE LOCKING WINGS).  
PUSH CONTACT INTO REAR INSULATOR UNTIL "WINGS" ON CONTACT SNAP OPEN.  
CONTACT SHOULD NOT EXTEND BEYOND THE BACK OF INSULATOR.  
PLACE FRONT INSULATOR ONTO REAR INSULATOR ASSURING PROPER ALIGNMENT OF CONTACTS.  
CONTINUE TO PUSH UNTIL FRONT AND REAR INSULATOR SNAP TOGETHER.  
LIGHTLY PULL CRIMPED WIRE TO ENSURE TERMINAL HAS LOCKED INTO INSULATOR.  
-WARNING PULLING TO HARD CAN DAMAGE CONTACT-

6 APPLY ADHESIVE LOCITE 416 OR EQUIVANT AROUND EACH WIRE AS SHOWN,  
WHERE WIRE ENTERS INSULATOR

7 MOUNT INSULATOR SUBASSEMBLY IN BACKSHELL SUBASSEMBLY  
PER ASSY INSTRUCTION. (SH2)

8 CLOSE BACKSHELL SUBASSEMBLY AROUND CABLE SHIELD PER  
INSTRUCTIONS. (SH 2)

9 CRIMP BACKSHELL TO METAL BRAID PER INSTRUCTIONS. (SH 2)  
SEE CRIMP SPEC.

	9 POSITION	15 POSITION	25 POSITION
MOLEX PRESS	622008900	622019800	622020000
CRIMP KIT	622009000	622019900	622020100

10 SLIDE BOOT OVER BACKSHELL SUBASSEMBLY.

11 INSERT JACKSCREWS INTO BOOT.

12 USE WITH MOLEX TERMINALS 830009502, 830009503 OR 830000083

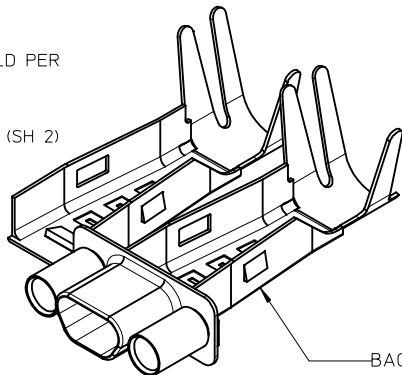
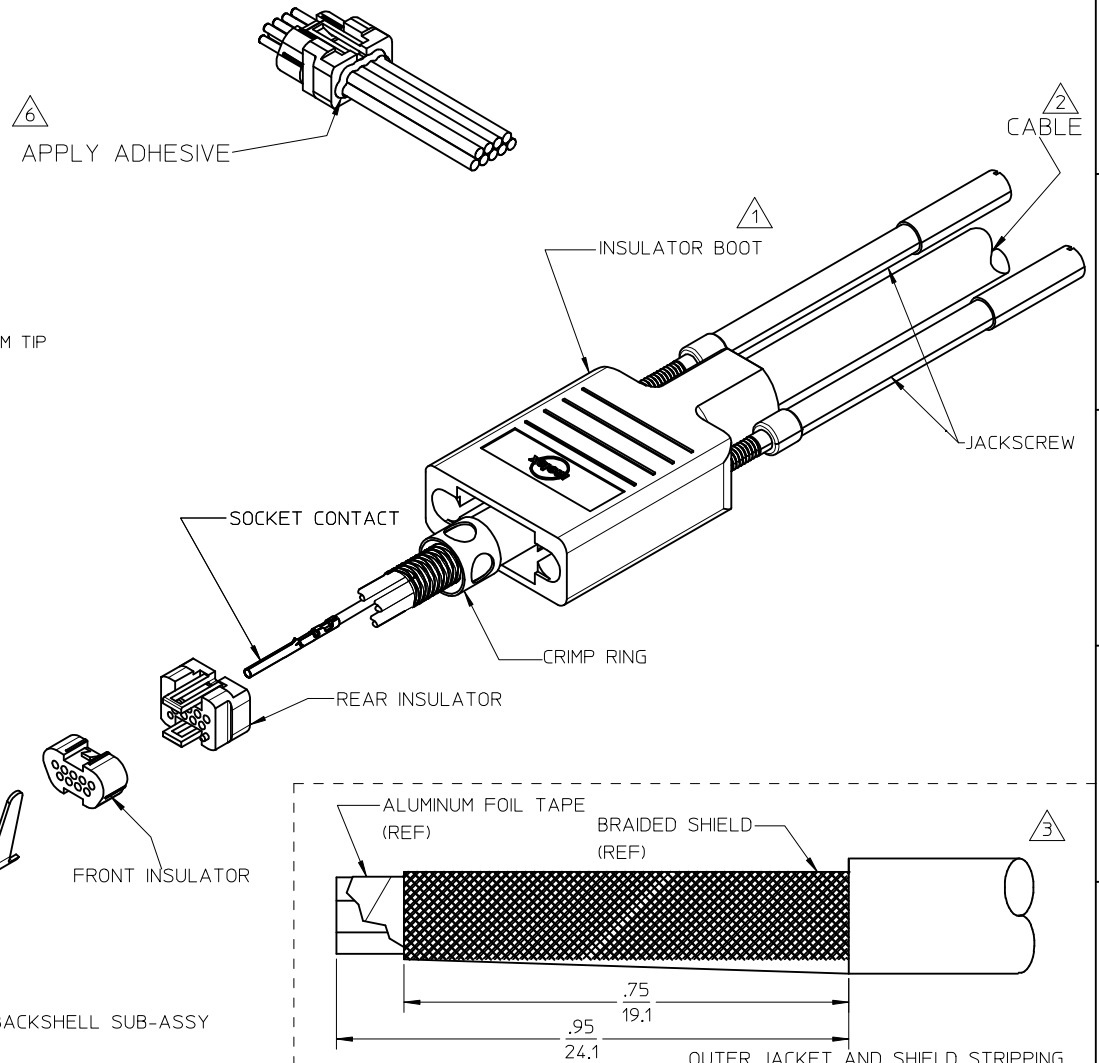

9 POSITION SHOWN

<b>ADDED VIEW &amp; NOTE</b> EC NO: IPG2014-1862 DRAWN:GGUSTAFSON 2014/04/25 CHKD: APPR:BWODMAN 2014/05/09	QUALITY SYMBOLS	DESCRIPTION
	▽=0	
	◻=0	
	REV	

GENERAL TOLERANCES (UNLESS SPECIFIED)	DIMENSION STYLE	SCALE	DESIGN UNITS
	IN/MM	2:1	INCH
4 PLACES ± ---	DRAWN BY	DATE	TITLE
3 PLACES ± ---	GGUSTAFSON	2014/03/26	ASSEMBLY INSTRUCTIONS
2 PLACES ± ---	CHECKED BY	DATE	COMMERCIAL MICRO D
1 PLACE ± ---	APPROVED BY	DATE	CONNECTOR
ANGULAR ± ---°	BWOODMAN	2014/04/04	MOLEX INCORPORATED
DRAFT WHERE APPLICABLE	MATERIAL NO.	DOCUMENT NO.	SHEET NO.
MUST REMAIN WITHIN DIMENSIONS	SEE CHART	SD-83421-040	1 OF 2

THIS DRAWING CONTAINS INFORMATION THAT IS PROPRIETARY TO MOLEX INCORPORATED AND SHOULD NOT BE USED WITHOUT WRITTEN PERMISSION
---

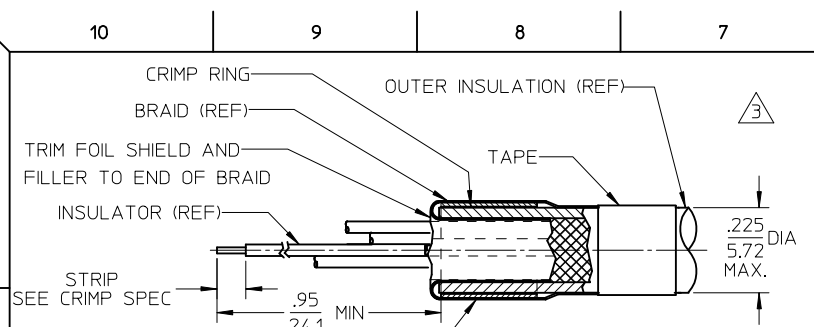

FOLD BRAID BACK OVER CRIMP RING AND COMB EVENLY 360° AROUND RING, PLACE ADHESIVE TAPE AROUND BRAID AS SHOWN  
**CONDUCTOR STRIPPING (SINGLE INSULATED WIRE)**

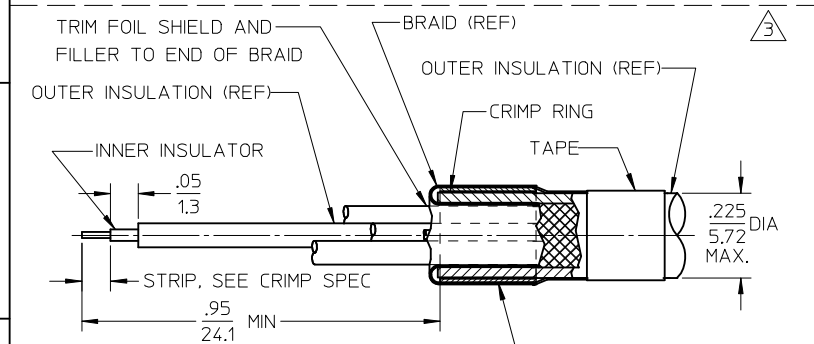

FOLD BRAID BACK OVER CRIMP RING AND COMB EVENLY 360° AROUND RING, PLACE ADHESIVE TAPE AROUND BRAID AS SHOWN.  
**CONDUCTOR STRIPPING DOUBLE INSULATED WIRE**

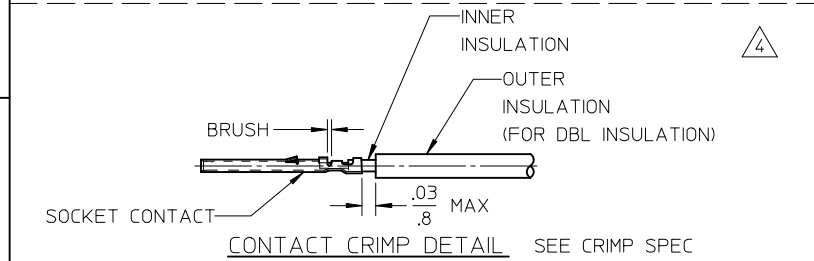

**CONTACT CRIMP DETAIL** SEE CRIMP SPEC

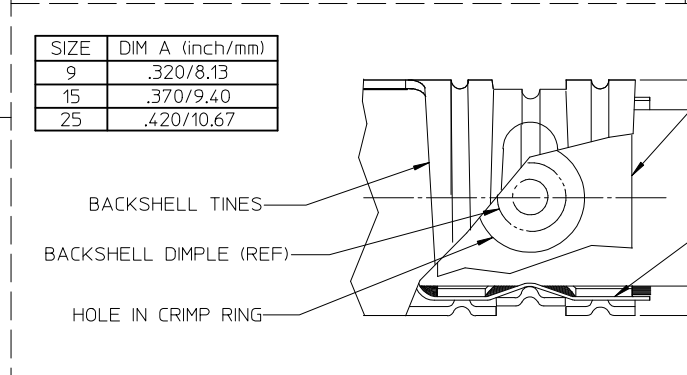
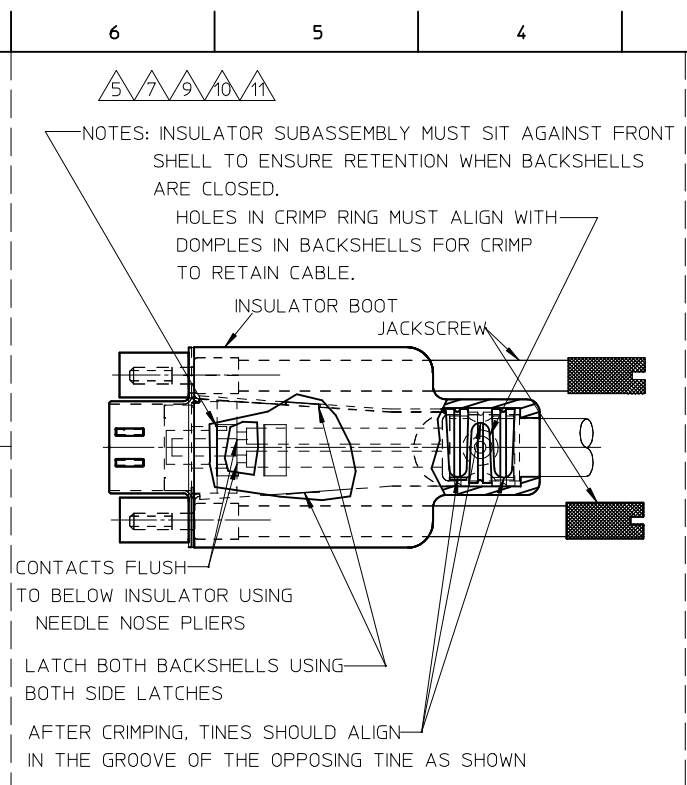
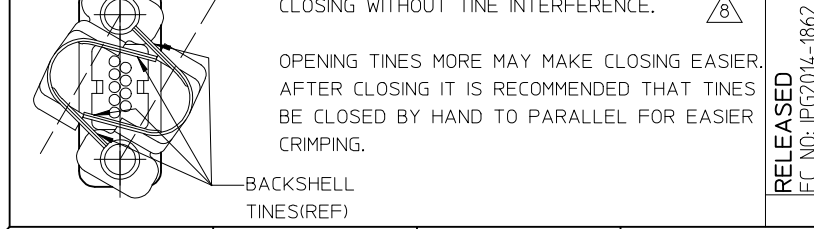

SIZE	DIM A (inch/mm)
9	.320/8.13
15	.370/9.40
25	.420/10.67

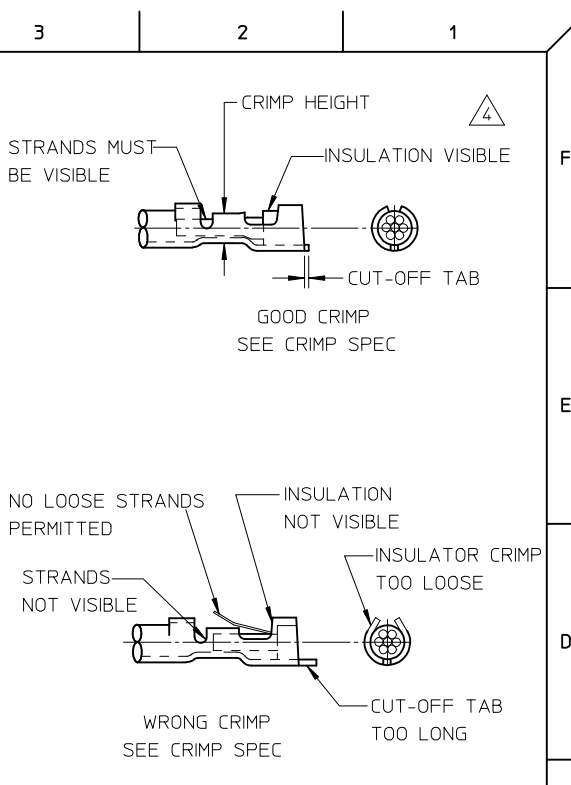

<b>RELEASED</b> EC NO: IPG2014-1862 DRWN:GGUSTAFSON 2014/04/25 CHKD: APPR:BWODMAN 2014/05/09 DESCRIPTION	<b>QUALITY SYMBOLS</b> ▽=0 ▽=0	<b>GENERAL TOLERANCES (UNLESS SPECIFIED)</b> <table border="1"> <thead> <tr> <th></th> <th>mm</th> <th>INCH</th> </tr> </thead> <tbody> <tr> <td>4 PLACES</td> <td>±---</td> <td>±---</td> </tr> <tr> <td>3 PLACES</td> <td>±---</td> <td>±---</td> </tr> <tr> <td>2 PLACES</td> <td>±---</td> <td>±---</td> </tr> <tr> <td>1 PLACE</td> <td>±---</td> <td>±---</td> </tr> <tr> <td colspan="3">ANGULAR ±---°</td> </tr> </tbody> </table>		mm	INCH	4 PLACES	±---	±---	3 PLACES	±---	±---	2 PLACES	±---	±---	1 PLACE	±---	±---	ANGULAR ±---°			<b>DIMENSION STYLE</b> IN/MM DRAWN BY: GGUSTAFSON DATE: 2014/03/26 CHECKED BY: _____ DATE: _____	<b>SCALE</b> 2:1 <b>DESIGN UNITS</b> INCH <b>THIRD ANGLE PROJECTION</b>	<b>TITLE</b> ASSEMBLY INSTRUCTIONS COMMERCIAL MICRO D CONNECTOR
		mm	INCH																				
4 PLACES	±---	±---																					
3 PLACES	±---	±---																					
2 PLACES	±---	±---																					
1 PLACE	±---	±---																					
ANGULAR ±---°																							
<b>DRAFT WHERE APPLICABLE MUST REMAIN WITHIN DIMENSIONS</b>	<b>APPROVED BY</b> BWODMAN DATE: 2014/04/04 <b>MATERIAL NO.</b> SEE CHART	<b>APPROVED BY</b> BWODMAN DATE: 2014/04/04 <b>MATERIAL NO.</b> SEE CHART	<b>MOLEX INCORPORATED</b> DOCUMENT NO. SD-83421-040	<b>SHEET NO.</b> 2 OF 2																			