

INSTALLATION INSTRUCTIONS: MCD DEVICENET MODULE

Order Code: 175G9002

1. Important User Information

Observe all necessary safety precautions when controlling the soft starter remotely. Alert personnel that machinery may start without warning.

It is the installer's responsibility to follow all instructions in this manual and to follow correct electrical practice.

2. Installation



CAUTION

Remove mains and control voltage from the soft starter before attaching or removing accessories. Failure to do so may damage the equipment.

Install the DeviceNet Module using the following procedure:

1. Remove control power and mains supply from the soft starter.
2. Attach the module to the soft starter as illustrated.
3. Set the DeviceNet Module Node Address (MAC ID) and Data Rate.
4. Apply control power to the soft starter.
5. Insert the network connector into the module and power up the DeviceNet network.

2.1. Physical Installation

1. Fully pull out the top and bottom retaining clips on the module.
2. Line up the module with the comms port slot.
3. Push in the top and bottom retaining clips to secure the module to the starter.

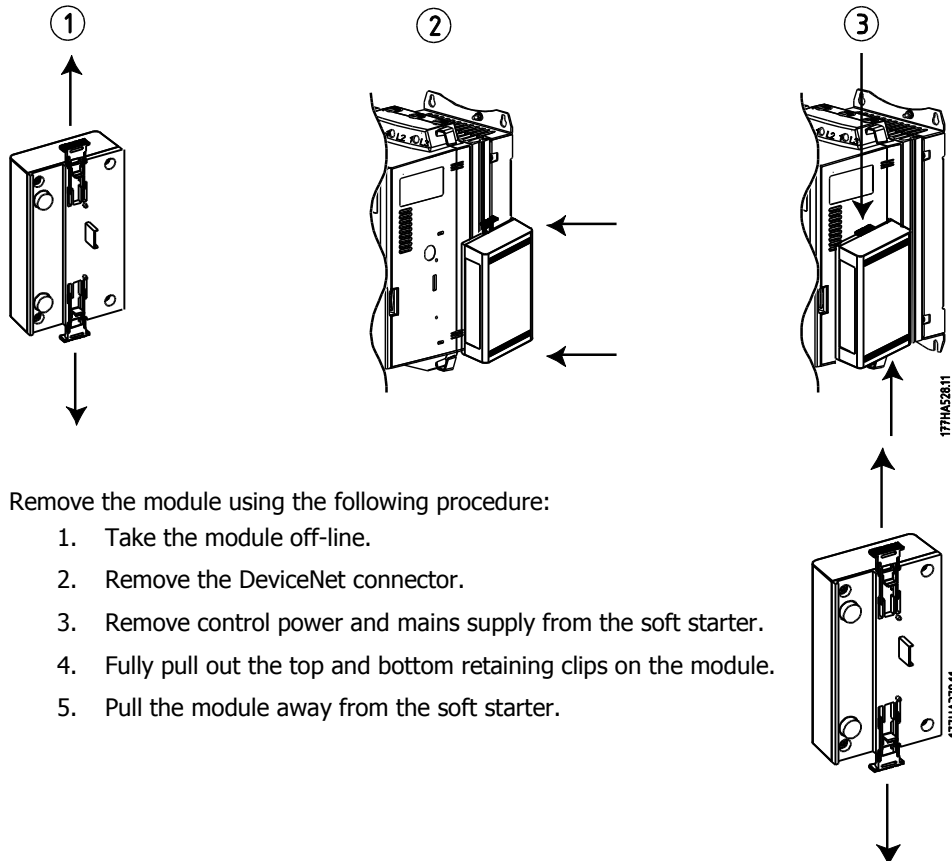

Remove the module using the following procedure:

1. Take the module off-line.
2. Remove the DeviceNet connector.
3. Remove control power and mains supply from the soft starter.
4. Fully pull out the top and bottom retaining clips on the module.
5. Pull the module away from the soft starter.



CAUTION

Network designs must decrease the maximum allowable cumulative dropline length by 400 mm for every module installed on the network. Failure to do so may result in network communication errors and decreased reliability.

Example: ODVA specifies a maximum cumulative dropline length of 156 m on a network operating at 125 kb/s. If six modules were installed on this network, the total cumulative dropline length would need to be decreased to 153.6 m.

3. Configuration

The DeviceNet Module is a Group 2 slave device, using a predefined master/slave connection set. I/O data is produced and consumed using polled I/O messaging.

The soft starter must be added to the DeviceNet manager project using the EDS file and configuration/management software tool. This file is available from www.danfoss.com/drives. In order to operate successfully, the correct EDS file must be used. An on-screen graphics bitmap file (device.bmp) is also available.

4. Adjustment

The factory default settings for the rotary adjustment switches are:

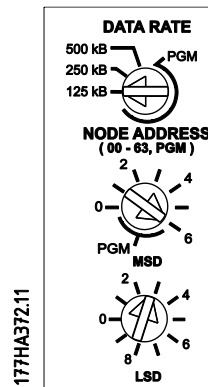

Changes to the rotary switch settings take effect when the DeviceNet network is next powered up.



N.B.!

The Data Rate and Node Address (MAC ID) must be set locally on the module. These cannot be set using DeviceNet management software.

When the Data Rate and MSD Node Address (MAC ID) rotary switches are set on PGM position, the module uses the previously used valid on-line Data Rate and Node Address (MAC ID).

5. Connection

MCD 200: For the MCD DeviceNet Module to accept serial commands, a link must be fitted across terminals A1-N2 on the soft starter.

In order for the MCD 500 to accept commands from the serial network, the soft starter must be in Auto On mode and links must be fitted to terminals 17, 18 and 25, 18.

In Hand On mode, the starter will not accept commands from the serial network but the starter's status can still be monitored.

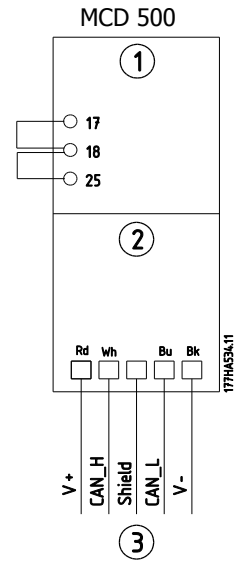
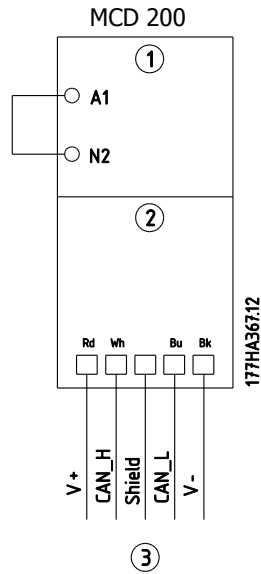

①	MCD 200	①	MCD 500 (Auto On mode) 17, 18: Stop 25, 18: Reset
②	MCD DeviceNet Module	②	MCD DeviceNet Module
③	Standard connection onto DeviceNet network	③	Standard connection onto DeviceNet network



N.B.!:

If MCD 500 parameter 3-2 *Comms in Remote* is set to Disable Comms in Remote, the starter will not accept start or stop commands from the serial network (the starter will still accept reset commands and allow status monitoring).

6. Module and Network LEDs

The Module LED indicates the condition of the power supply and module operation.

The Network LED indicates status of the communication link between the DeviceNet Module and the network Master.

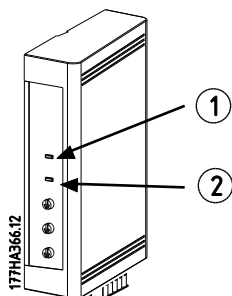

LED	State	Description
① (Module)	Off	Network power off
	Green	Normal operation
	Red	Unrecoverable fault
	Red/Green flashing	Self Test mode
② (Network)	Off	Duplicate MAC ID test has not been completed
	Green flashing	Online but no connection with Master
	Green	Online and allocated to a Master
	Red flashing	One or more timed out I/O connections
	Red	Failed communication between module and Master
	Red/Green flashing	Communication faulted and received an Identity communication faulted request

**N.B.!**

When a communications failure occurs, the soft starter may trip if the Communication Timeout parameter for the network is set greater than zero. When communication is restored, the soft starter must be reset.

7. DeviceNet Polled I/O Structure

Once the EDS file has been loaded, the DeviceNet Module must be added to the scanner list with parameters shown in the following table:

Parameter	Value
I/O connection type	Polled
Poll receive size	14 bytes
Poll transmit size	2 bytes

Once the soft starter, module and Master have been set up, configured and powered up, the Master will transmit 2 bytes of data to the module and receive 14 bytes of data from the module.

Master > Slave polled I/O output data is as follows:

Byte	Bit	Function
0	0	0 = Stop command 1 = Start command
	1	0 = Enable Start or Stop command 1 = Quick Stop (i.e. coast to stop) and disable Start command
	2	0 = Enable Start or Stop command 1 = Reset command and disable Start command
	3 to 7	<i>Reserved</i>
1	0 to 1	0 = Use soft starter remote input to select motor set 1 = Use primary motor set when starting ¹ 2 = Use secondary motor set when starting ¹ 3 = <i>Reserved</i>
	2 to 7	<i>Reserved</i>

¹ Ensure that the programmable input is not set to Motor Set Select before using this function.

Slave > Master polled I/O input data is as follows:

Byte	Bit	Function	Value
0	0	Trip	1 = Tripped
	1	Warning	1 = Warning
	2	Running	0 = Unknown, not ready, ready to start or tripped 1 = Starting, running, stopping or jogging
	3	<i>Reserved</i>	
	4	Ready	0 = Start or stop command not acceptable 1 = Start or stop command acceptable
	5	Control from Net	1 = Always except in Program mode
	6	Local/Remote	0 = Local control 1 = Remote control
	7	At reference	1 = Running (full voltage at the motor)
1	0 to 7	Status	0 = Unknown (menu open) 2 = Starter not ready (restart delay, thermal delay or run simulation) 3 = Ready to start (including warning state) 4 = Starting or running 5 = Soft stopping 7 = Trip 8 = Jog forward 9 = Jog reverse
2	0 to 7	Trip/Warning code	See trip code table.
3	0	Initialised	1 = Phase sequence bit is valid (bit 1) after 1 st start
	1	Phase sequence	1 = Positive phase sequence detected
	2 to 7	<i>Reserved</i>	
4 ¹	0 to 7	Motor current (low byte)	Current (A)
5 ¹	0 to 7	Motor current (high byte)	
6	0 to 7	Current %FLC (low byte)	Current as a percentage of soft starter FLC setting (%)
7	0 to 7	Current %FLC (high byte)	
8	0 to 7	% Motor 1 temperature	Motor 1 thermal model
9	0 to 7	% Motor 2 temperature	Motor 2 thermal model
10	0 to 7	% Power factor	Percentage power factor (100 = power factor of 1)
11	0 to 7	Power (low byte)	Power low byte, scaled by power scale
12	0 to 3	Power (high nibble)	Power high nibble, scaled by power scale
	4 to 5	Power scale	0 = Multiply power by 10 to get W 1 = Multiply power by 100 to get W 2 = Power (kW) 3 = Multiply power by 10 to get kW
	6 to 7	<i>Reserved</i>	
13	0 to 3	Digital Input state	0 = Start (0 = open, 1 = closed) 1 = Stop 2 = Reset 3 = Input A
	4 to 7	<i>Reserved</i>	

¹ For models MCD5-0428C and smaller this value will be 10 times greater than the value displayed on the LCP.

7.1.1. Trip Codes

Code	Trip Type	MCD 201	MCD 202	MCD 500
0	No trip	■	■	■
11	Input A trip			■
20	Motor overload (thermal model)		■	■
21	Heatsink overtemperature			■
23	L1 phase loss			■
24	L2 phase loss			■
25	L3 phase loss			■
26	Current imbalance		■	■
28	Instantaneous overcurrent			■
29	Undercurrent			■
50	Power loss/Power circuit	■	■	■
54	Phase sequence		■	■
55	Frequency (Mains supply)	■	■	■
60	Unsupported option (function not available in inside delta)			■
61	FLC too high (FLC out of range)			■
62	Parameter out of Range			■
70	Miscellaneous			■
75	Motor thermistor		■	■
101	Excess start time		■	■
102	Motor connection			■
104	Internal fault x (where x is the fault code detailed in the table below).			■
113	Starter communication (between module and soft starter)	■	■	■
114	Network communication (between module and network)	■	■	■
115	L1-T1 shorted			■
116	L2-T2 shorted			■
117	L3-T3 shorted			■
119★	Time-overcurrent (Bypass overload)		■	■
121	Battery/clock			■
122	Thermistor circuit			■

★ For MCD 500, time-overcurrent protection is only available on internally bypassed models.

The table below details the internal fault code associated with trip code 104.

Internal fault	Message displayed on the LCP
70 ~ 72	Current Read Err Lx
73	Power On in Simulation mode
74 ~ 76	Motor connection Tx
77 ~ 79	Firing fail SCR _x
80 ~ 82	VZC Fail P _x
83	Low Control Volts
84 ~ 98	Internal fault X Contact your local supplier with the fault code (X).

8. Parameter Object

The DeviceNet Module supports parameter objects through explicit messaging. Soft starter parameters can be uploaded (written) and downloaded (read) using DeviceNet management software. When the DeviceNet Module is powered up, it automatically obtains parameter information from the soft starter.

Detail	Value (Hex)	Comment
Class	0F	Parameter object address
Instance	1 ~ xxx	xxx = maximum soft starter parameter number
Attribute ID	01	Always 0x01
Get Service	0E	Read single soft starter parameter value
Set Service	10	Write single soft starter parameter value



N.B.!:

Only available on MCD 500 soft starters. For parameter details, see the soft starter User Manual.

9. Specifications

Enclosure

Dimensions	40 mm (W) x 166 mm (H) x 90 mm (D)
Weight	250 g
Protection	IP20

Mounting

Spring-action plastic mounting clips (x 2)

Connections

Soft starter	6-way pin assembly
Network	5-way male and unpluggable female connector (supplied)
Maximum cable size	2.5 mm ²
Contacts	Gold flash

Settings

Node address (MAC ID)

Setting	Rotary switches
Range	0 to 63 (63, factory default)

Data rate

Setting	Rotary switch
Options	125 kB, 250 kB, 500 kB (125 kB, factory default)

Power

Consumption

steady state	19 mA at 25 VDC
.....	31 mA at 11 VDC
in-rush (at 24 VDC)	1.8 A maximum for 2 ms

Galvanically isolated

Certification

CE	IEC 60947-4-2
----------	---------------

