

NC1V



IDEC's original Spring-up Terminals and Cover.
Provide IP20 Finger-safe Protection.



- Note: TÜV, CE, and CCC marks are applicable for series trip type only.
- See website for details on approvals and standards.

Finger-safe, spring-up terminal reduces wiring time.

Ring terminal tabs can be installed easily, and screws are held captive.

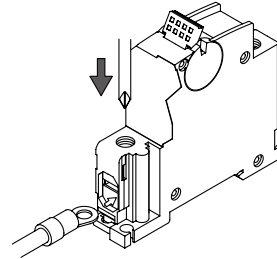

Main Circuit Terminals are Fingersafe (IP20)

Spring-up, fingersafe structure requires no terminal cover.



Auxiliary/Alarm Contact Terminals are Equipped with a Terminal Cover

Auxiliary/Alarm contact terminals are equipped with a terminal cover



Retractable Actuator

The actuator is retracted while the circuit protector is turned on. Inadvertent operation, due to touching the actuator, can be prevented.

Rated Short-circuit Capacity 2500A

Available with Inertial Delay

Allows for use with large inrush currents such as motors

Safe Trip-free Mechanism

The circuit remains open even when the operator is turned on after tripping (unit must be manually reset after removing the cause of the tripping).

Padlock Attachment

Locks the retractable actuator in the off position to prevent NC1V from being switched on inadvertently.



NC1V Circuit Protectors

IDEC's original spring-up, fingersafe terminals enhance reliability and safety.

Specifications

Shape			
Part No.	NC1V		
Operator Style	Retractable actuator		
Internal Circuit	Series trip (current trip)		
Protection Method	Hydraulic magnetic tripping system		
No. of Poles	1-pole	2-pole	3-pole
Rated Voltage (AC/DC) (*1)	250V AC 50/60Hz, 65V DC	250V AC 50/60Hz, 125V DC	250V AC, 50/60Hz
Series Trip (Current Trip)	Rated Short-circuit Capacity	250V AC, 2500A 65V DC, 2500A	250V AC, 2500A 125V DC, 2500A
	Rated Current	0.1A, 0.3A, 0.5A, 1A, 2A, 3A, 5A, 7A, 10A, 15A, 20A, 25A, 30A	
	Trip Characteristics (*2)	Time delay curve curve M (slow), curve A (medium), S (instantaneous) Curves M and A are available with inertial delay.	
Auxiliary Contact/Alarm Contact	Contact Rating	125V AC 3A (resistive load), 30V DC 2A (resistive load)	
	Minimum Applicable Load	24V DC 1mA (resistive load, reference value)	
Insulation Resistance	100 MΩ minimum (500V DC megger)		
Dielectric Strength	2000V AC, 1 minute (between terminals when main contacts are open, between live parts of different poles, between live and dead parts) 600V AC (between terminals when auxiliary circuits are open)		
Vibration Resistance (with rated current applied)	Damage limits: 147 m/s ² (10 to 55 Hz) (1-pole, 2-pole), 78 m/s ² (3-pole) Operating extremes: 98 m/s ² (1-pole, 2-pole), 78 m/s ² (3-pole)		
Shock Resistance (S time delay curve: 80% rated current, A, M time delay curve: 100% rated current)	Damage limits: 490 m/s ² (1-pole, 2-pole), 297 m/s ² (3-pole) Operating extremes: 196 m/s ²		
Electrical Life	10,000 cycles minimum (at rated current), 10 operations per minute		
Reference Temperature	40°C		
Operating Temperature	-10 to +60°C (no freezing) Rated current is based on an ambient temperature of 40°C. When the operating temperature exceeds 40°C, derate the rated current by using the factors shown below.		
Storage Temperature	-40 to +60°C (no freezing)		
Operating Humidity	45 to 85% RH (no condensation)		
Storage Humidity	45 to 85% RH (no condensation)		
Terminal Style	Main Circuit Terminal	Spring-up, fingersafe terminal: M4 screw (up to 20A), M5 screw (25A and 30A)	
	Auxiliary/Alarm Contacts, Voltage Coil Terminal	M3.5 screw	
Weight (approx.)	1-pole: 90g, 2-pole: 170g, 3-pole: 260g		

*1) 3-pole type is for AC voltage only.

*2) For S (instantaneous) tripping curve, humming sound may be caused when used in an AC sinusoidal-wave current circuit around 80% of the rated current, however, the performance of the circuit protector will not be affected.
To avoid unnecessary tripping, do not use in circuits where inrush currents may be present.

• Do not use the NC1V circuit protectors in environments where they are exposed to extreme temperature, humidity, dust, corrosive gases, vibration, shock, or in a circuit where inrush current may be present, otherwise unnecessary operations and damage may occur.

Operating Temp.	Derating Factor
50°C	0.9
55°C	0.8
60°C	0.7



NC1V Circuit Protectors

Part No. Development

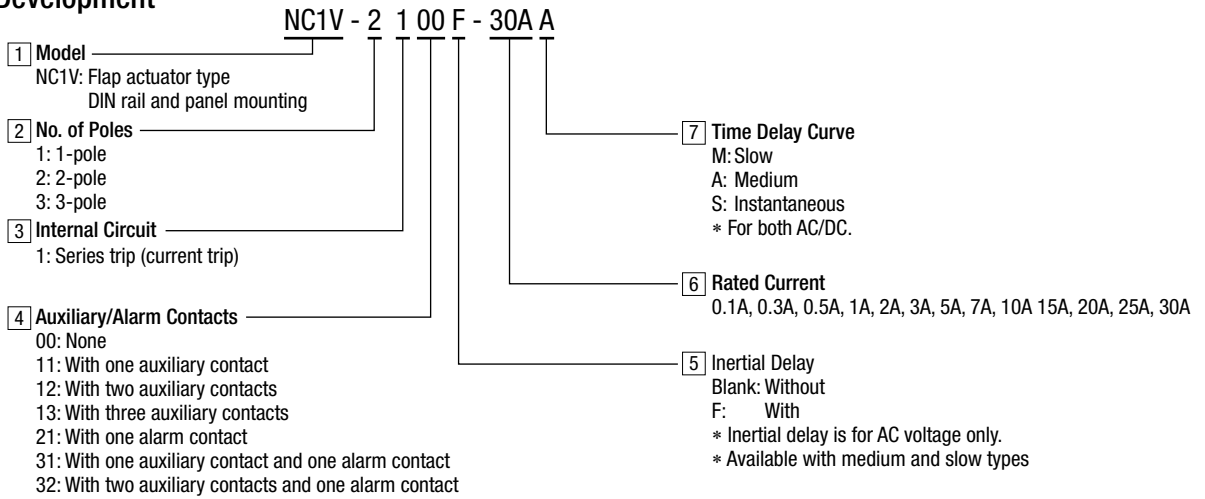

• Specify rated current, time delay curve, or voltage trip coil voltage in place of [6][7][8] in the Part No.

Internal Circuit	No. of Poles	Inertial Delay	Auxiliary Contact Alarm Contact	Part No.	Code		
					[6] Rated Current	[7] Time Delay Curve	
Series Trip (Current Trip)	1-pole	—	—	NC1V-1100-[6][7]	0.1A 0.3A 0.5A 1A 2A 3A 5A 7A 10A 15A 20A 25A 30A	M (slow) A (medium) S (instantaneous)	
			One Auxiliary Contact	NC1V-1111-[6][7]			
			One Alarm Contact	NC1V-1121-[6][7]			
		With	—	—			NC1V-1100F-[6][7]
				One Auxiliary Contact			NC1V-1111F-[6][7]
				One Alarm Contact			NC1V-1121F-[6][7]
	—		—	—			NC1V-2100-[6][7]
				One Auxiliary Contact			NC1V-2111-[6][7]
				Two Auxiliary Contacts			NC1V-2112-[6][7]
		With	—	One Alarm Contact			NC1V-2121-[6][7]
				One Auxiliary Contact and One Alarm Contact			NC1V-2131-[6][7]
				—			NC1V-2100F-[6][7]
	—		—	One Auxiliary Contact			NC1V-2111F-[6][7]
				Two Auxiliary Contacts			NC1V-2112F-[6][7]
				One Alarm Contact			NC1V-2121F-[6][7]
		One Auxiliary Contact and One Alarm Contact	—	—			NC1V-2131F-[6][7]
				—			NC1V-3100-[6][7]
				—			NC1V-3100F-[6][7]
	3-pole		—	One Auxiliary Contact			NC1V-3111-[6][7]
				Two Auxiliary Contacts			NC1V-3112-[6][7]
				Three Auxiliary Contacts			NC1V-3113-[6][7]
		One Alarm Contact		NC1V-3121-[6][7]			
		One Auxiliary Contact and One Alarm Contact		NC1V-3131-[6][7]			
		Two Auxiliary Contacts and One Alarm Contact		NC1V-3132-[6][7]			
With		—	—	NC1V-3100F-[6][7]			
			One Auxiliary Contact	NC1V-3111F-[6][7]			
			Two Auxiliary Contacts	NC1V-3112F-[6][7]			
		One Alarm Contact	Three Auxiliary Contacts	NC1V-3113F-[6][7]			
			—	NC1V-3121F-[6][7]			
			One Auxiliary Contact and One Alarm Contact	NC1V-3131F-[6][7]			
Two Auxiliary Contacts and One Alarm Contact	—	NC1V-3132F-[6][7]					

Note: Inertial delay is for AC circuit. Also, time delay curve of S (instantaneous) is not available with inertial delay.

Internal Circuit

1-pole

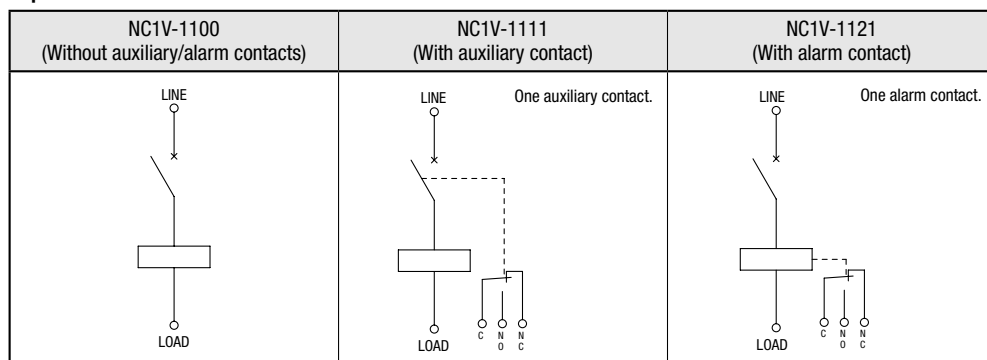

2-pole

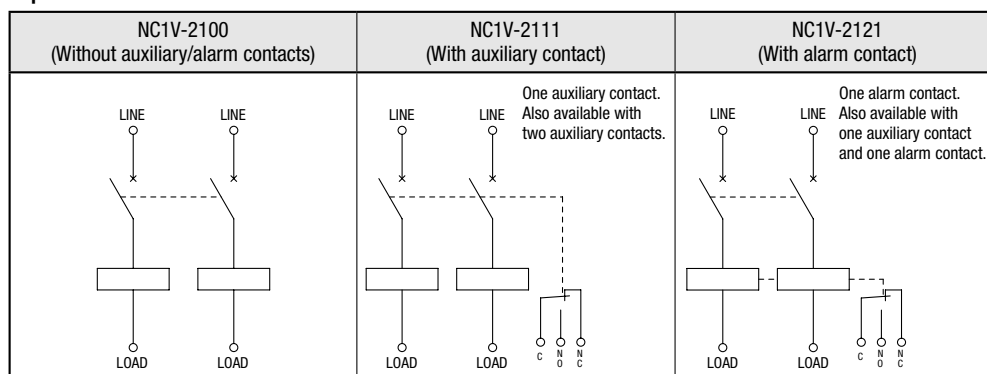

3-pole

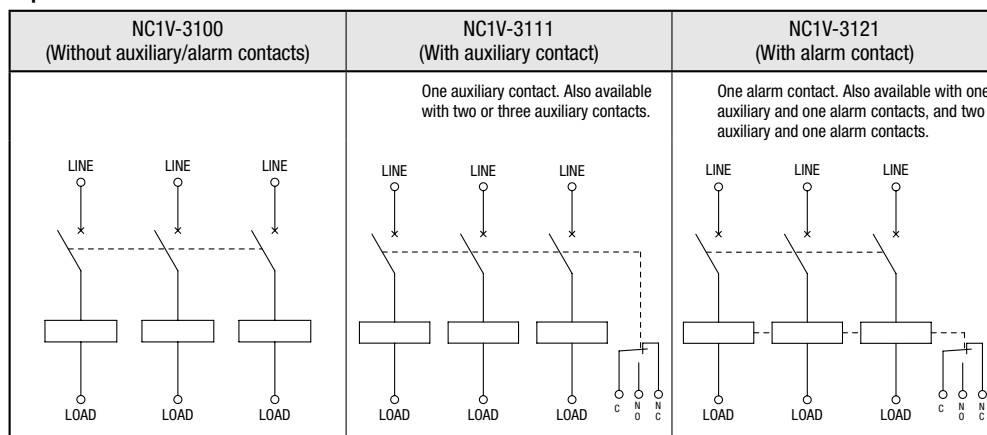

Overcurrent-Time Delay Characteristics (sec at 40°C) [vertical mounting]

Item	Time Delay Curve	Percent of Rated Current								
		100%	125%	150%	175%	200%	400%	600%	800%	1000%
AC (50/60 Hz)/DC	S (instantaneous)	NO TRIP	—	*0.005 to 0.1	0.003 to 0.06	0.0027 to 0.05	0.002 to 0.03	0.002 to 0.028	0.002 to 0.025	0.002 to 0.022
	A (medium)	NO TRIP	*25 to 240	16 to 140	—	6 to 32	0.4 to 4	0.0055 to 1.5	0.004 to 0.8	0.004 to 0.65
	M (slow)	NO TRIP	*60 to 600	30 to 200	—	9 to 60	0.4 to 10	0.006 to 4.5	0.004 to 1.8	0.004 to 0.8
AC (50/60 Hz)	With Inertial Delay A (medium)	NO TRIP	25 to 240	—	—	6 to 32	0.8 to 6	0.09 to 3.5	0.02 to 1.8	0.01 to 1.0
	With Inertial Delay M (slow)	NO TRIP	60 to 600	—	—	10 to 60	0.8 to 10	0.06 to 4.5	0.02 to 3	0.01 to 1.75

*: May trip on DC.



- APEM
- Switches & Pilot Lights
- Control Boxes
- Emergency Stop Switches
- Enabling Switches
- Safety Products
- Explosion Proof
- Terminal Blocks
- Relays & Sockets
- Circuit Protectors
- Power Supplies
- LED Illumination
- Controllers
- Operator Interfaces
- Sensors
- AUTO-ID

Time Delay Curves at 40°C

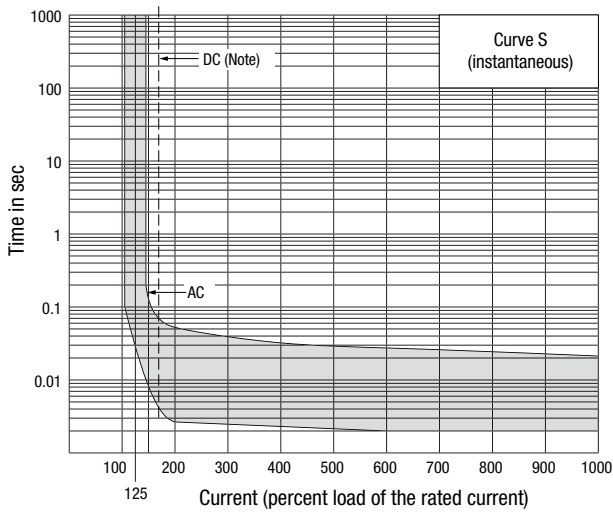
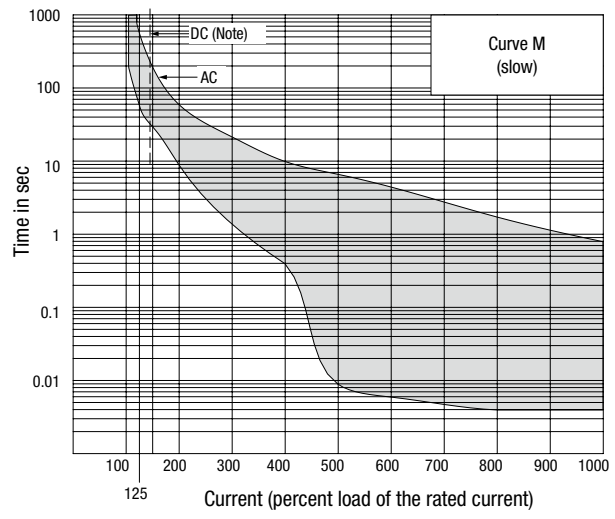
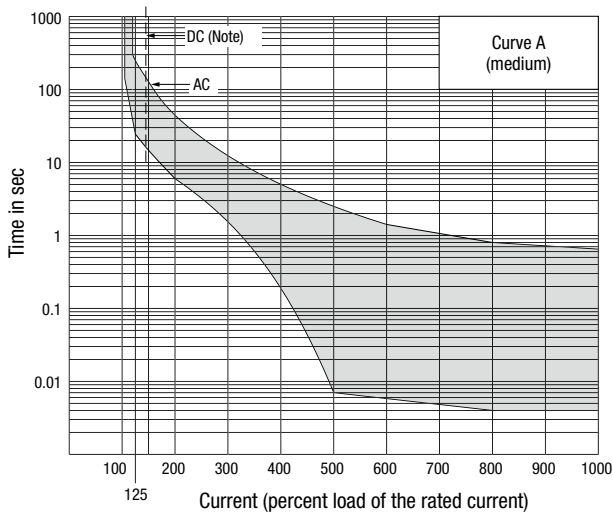

Note: The entire shaded area applies to AC.
For DC, the shaded area on the right of the dashed line applies.

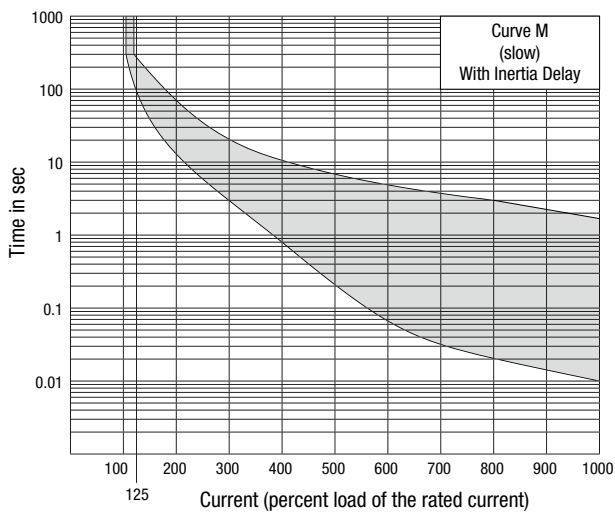
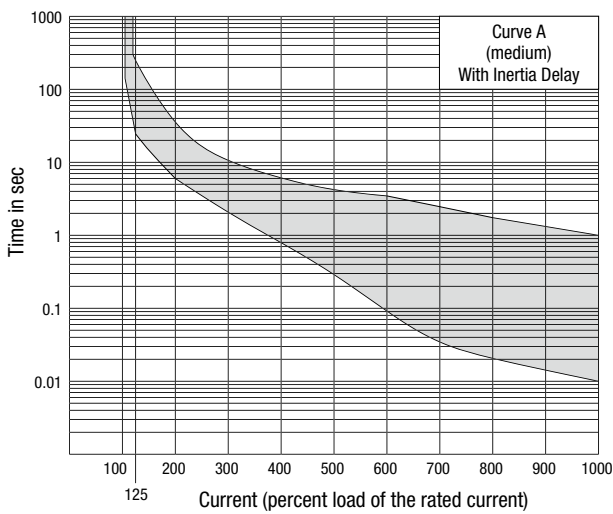

- APEM
- Switches & Pilot Lights
- Control Boxes
- Emergency Stop Switches
- Enabling Switches
- Safety Products
- Explosion Proof
- Terminal Blocks
- Relays & Sockets
- Circuit Protectors**
- Power Supplies
- LED Illumination
- Controllers
- Operator Interfaces
- Sensors
- AUTO-ID
- NC1V**

Time Delay Curve and Ambient Temperature

NC1V circuit protectors employ an electromagnetic tripping system, where the rated current (trip current) is not affected by ambient temperatures. But the time delay may vary with the oil viscosity in the oil dash pot. Lower oil viscosity at higher temperatures results in a shorter delay, whereas at lower temperatures the delay will be longer.

Temperature Correction Curve

The time delay curves on the preceding page are measured at 40°C. With reference to the following curves, time delays can be corrected according to ambient temperature.

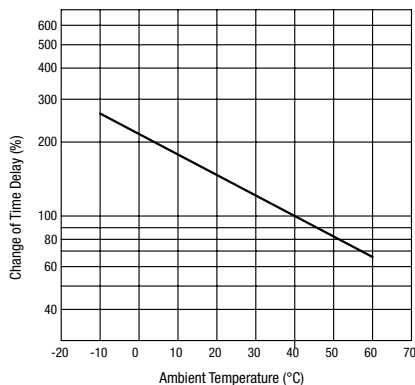

The time delay is based on an ambient temperature of 40°C. Time delays at other temperatures are corrected according to the temperature correction curve. The time delay of the instantaneous time delay curve (S) is not affected by the ambient temperature.

When operating temperature exceeds 40°C, derate the rated current by multiplying the derating factor shown on the right.

Operating Temp.	Derating Factor
50°C	0.9
55°C	0.8
60°C	0.7

Inertial Delay

Inertial delay is designed not to trip on a non-repeating single pulse of 20 times the rated current (peak value) for a duration of 8 ms. In addition, circuit protectors equipped with inertial delay do not respond to high inrush currents caused by transformer or lamp loads, but perform the specified interruption on the subsequent overcurrents. Inertial delay is available on AC circuits, and is not available with the series trip curve S (instantaneous).

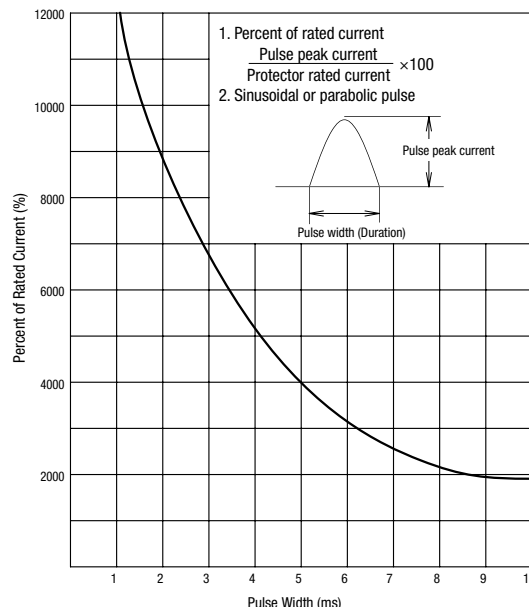

Impedance and Coil Resistance

Series Trip (Current Trip) (initial value) at 25°C

Rated Current	For AC 50/60 Hz Impedance (Ω)		For DC Resistance (Ω)	
	Curve S	Curves A, M	Curve S	Curves A, M
0.1A	66.0	116.0	43.0	106.0
0.3A	6.6	11.0	4.1	10.0
0.5A	1.92	3.65	0.86	3.40
1A	0.50	0.93	0.25	0.90
2A	0.16	0.27	0.11	0.25
3A	0.07	0.12	0.050	0.11
5A	0.025	0.050	0.015	0.045
7A	0.014	0.027	0.011	0.025
10A	0.007	0.021	0.005	0.020
15A	0.006	0.010	0.005	0.009
20A	0.005	0.006	0.004	0.005
25A	0.004	0.005	0.004	0.005
30A	0.003	0.004	0.003	0.004

Tolerance: ±25% (up to 20A),
±50% (25A and 30A)

Voltage Drop Due to Coil Resistance or Impedance

The internal resistance or impedance of a circuit protector tends to be larger for a smaller rated current. Therefore, when circuit protectors of a small rated current are used, voltage drop should be taken into consideration. Internal resistance also varies with time delay curves, which should also be considered during installation.

Main Contact - Auxiliary/Alarm Contact

[Auxiliary Contact]

Main Contact	NO ontact	NC Contact
ON	closed	open
Tripped	open	closed
OFF	open	closed

[Alarm Contact]

Main Contact	NO ontact	NC Contact
ON	open	closed
Tripped	closed	open
OFF	open	closed

- APEM
- Switches & Pilot Lights
- Control Boxes
- Emergency Stop Switches
- Enabling Switches
- Safety Products
- Explosion Proof
- Terminal Blocks
- Relays & Sockets
- Circuit Protectors**
- Power Supplies
- LED Illumination
- Controllers
- Operator Interfaces
- Sensors
- AUTO-ID

NC1V Circuit Protectors

Dimensions

1-pole

All dimensions in mm.

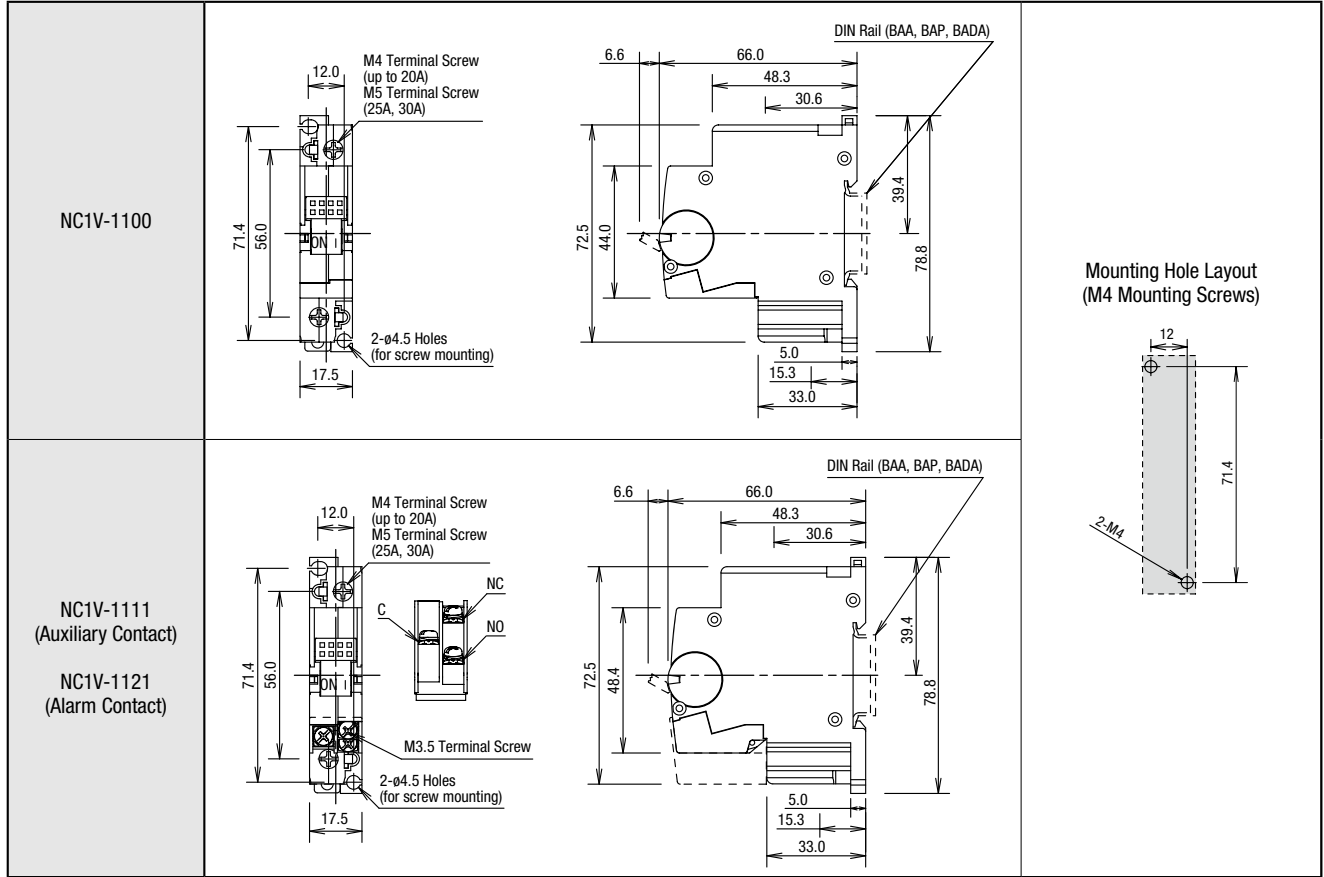

2-pole

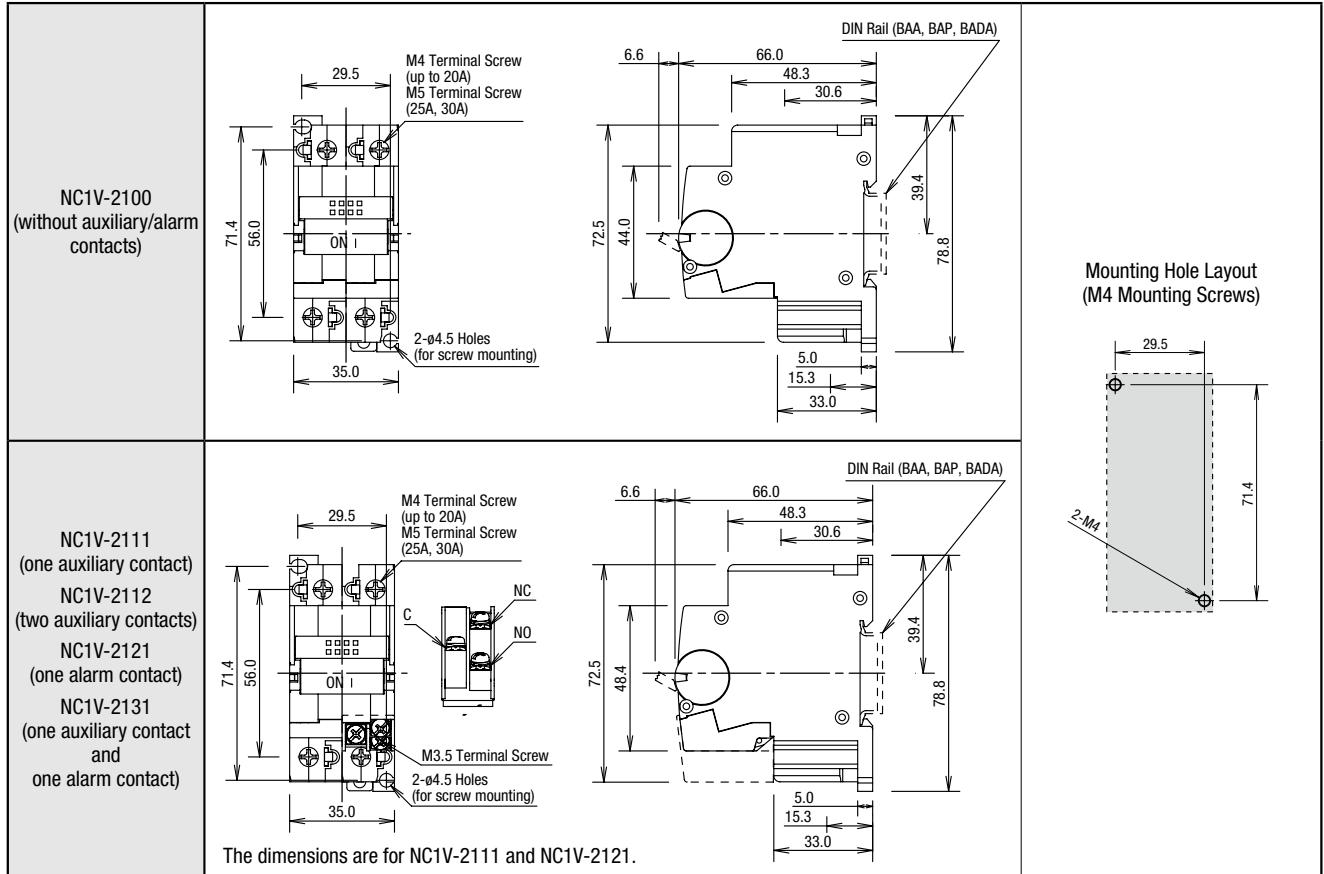

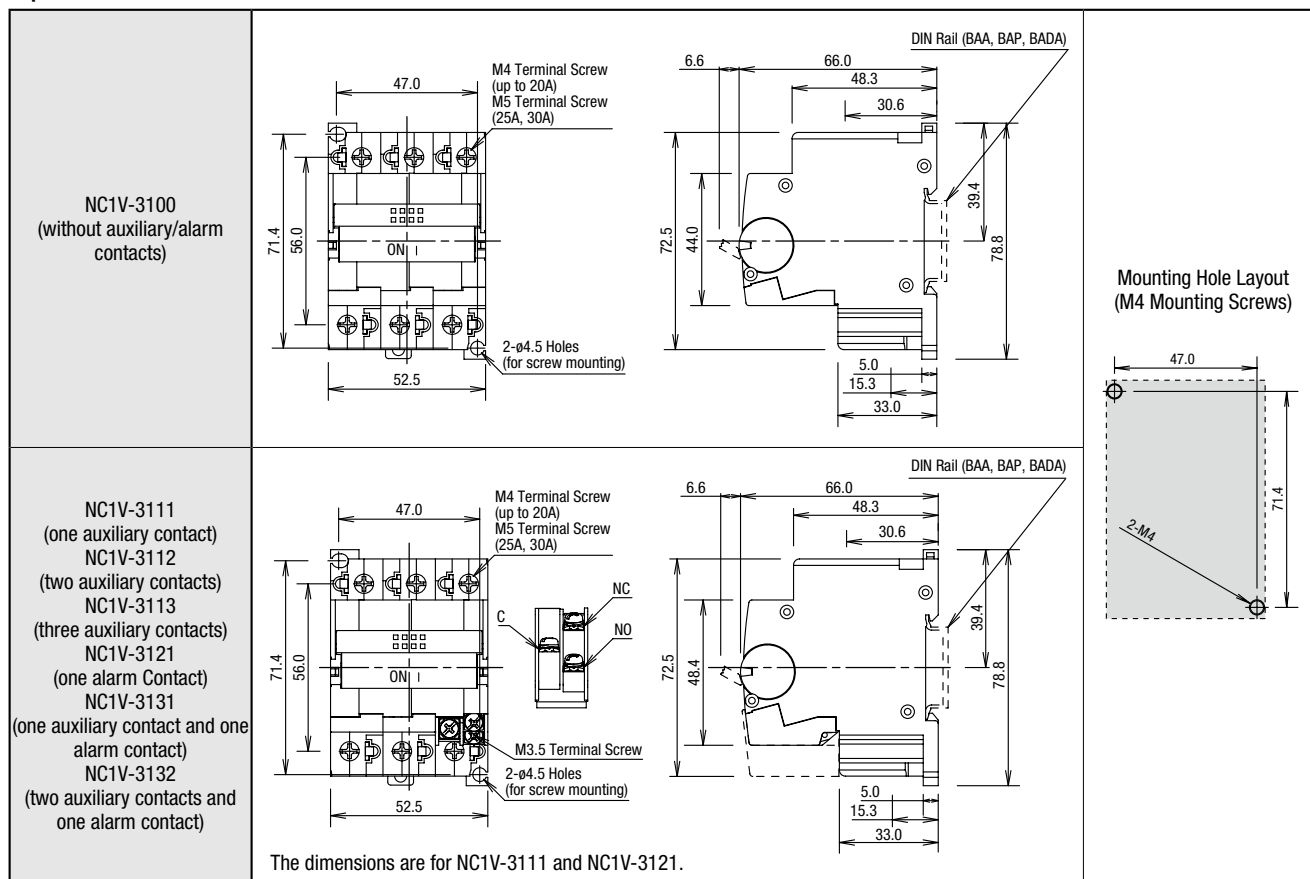

3-pole



- APEM
- Switches & Pilot Lights
- Control Boxes
- Emergency Stop Switches
- Enabling Switches
- Safety Products
- Explosion Proof
- Terminal Blocks
- Relays & Sockets
- Circuit Protectors**
- Power Supplies
- LED Illumination
- Controllers
- Operator Interfaces
- Sensors
- AUTO-ID

Accessories

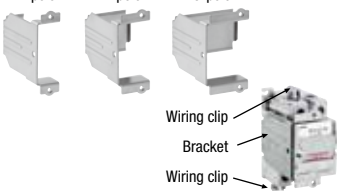
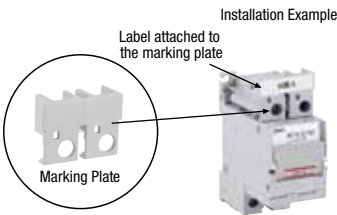
All dimensions in mm.

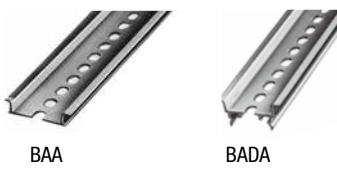
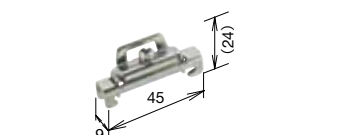
Shape	Material	Part No.	Ordering No.	Package Quantity	Remarks
Panel Mounting Bracket (Note) 1-pole 2-pole 3-pole 	Bracket: Steel Wiring clip: brass (terminal), steel (screw, washer)	NC9Z-MA11	NC9Z-MA11	1	<ul style="list-style-type: none"> Used for mounting NC1V circuit protectors in a panel cut-out. Supplied with two wiring clips for each pole, used for wiring from the rear. For 1-pole: 2 wiring clips For 2-pole: 4 wiring clips For 3-pole: 6 wiring clips
1-pole		NC9Z-MA21	NC9Z-MA21		
2-pole		NC9Z-MA31	NC9Z-MA31		
Marking Plate 	PBT	NC9Z-PW1	NC9Z-PW1PN10	10	<ul style="list-style-type: none"> Available for 2-pole circuit only. For use on 1-pole circuit protectors, break the marking plate into two halves. Label is supplied by the user.
Padlock Attachment 	Polyamide body with stainless steel pin	NC9Z-LK1	NC9Z-LK1	1	<ul style="list-style-type: none"> Locks the retractable actuator in the off position to prevent NC1V from being switched on inadvertently. Can be used on 1-, 2-, and 3-pole.
DIN Rail (35mm-wide) 	Aluminum	BAA1000	BAA1000PN10	10	<ul style="list-style-type: none"> Weight: approx. 200g See H-071 for details on DIN rail products.
Length: 1000mm		BADA1000	BADA1000PN10		
End Clip 	Steel (trivalent chromate)	BNL6	BNL6PN10	10	<ul style="list-style-type: none"> Applicable rail: BAA, BAP, BADA Weight: approx. 15g See H-071 for details on DIN rail products.

Note: Cannot be used with NC1V with auxiliary or alarm contact.

Accessories

Dimensions

All dimensions in mm.

NC9Z-MA Panel Mounting Bracket

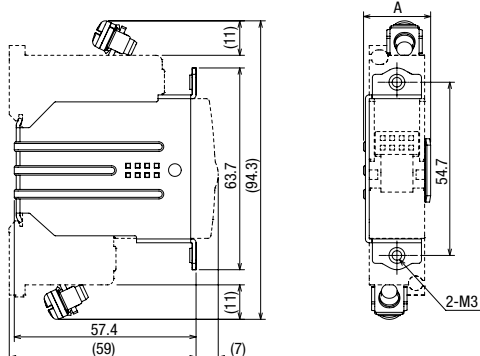

Dimensions A and B

Dimension	A	B
1-pole	21.2	17.8
2-pole	38.7	35.3
3-pole	56.2	52.8

Mounting Hole Layout

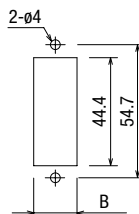

NC9Z-TA1 Wiring Clip

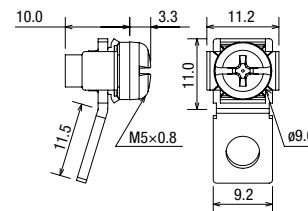

Insulation Sleeve

When using wiring clips on 2- or 3-pole circuit protectors, install UL/CSA-rated insulation sleeves on the crimping terminals to ensure the air gap required by UL1077. Applicable Insulation Sleeves (Example)

- Nissei Eco (V-38)
- Tokyo Dip (TP-038)
- Nichifu (TIC38)

Applicable Crimping Terminal

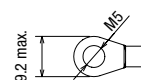

Tightening torque: 1.8 to 2.2 N-m

Materials

- Panel Mounting Bracket: Steel
- Wiring Clip: Brass (terminal strip) Steel (screw, washer)

Panel Mounting Screw Length (Dimension C in mm)

Applicable Panel Thickness: 0.8 to 3.2 mm

The outside diameter of the M3 screw (including washer) must be 7 mm maximum.

Panel thickness (mm)		0.8	1.0	1.2	1.4	1.6	1.8	2.0	2.3	2.6	3.2
Without washer		5	5	6	6	6	6	6	8	8	8
With plain washer (0.5 thick)		6	6	6	6	6	6	8	8	8	8
With spring washer (0.7 thick)		6	6	6	6	6	8	8	8	8	8
With plain washer (0.5 thick) and spring washer (0.7 thick)		6	6	6	8	8	8	8	8	8	8
Countersunk head screw		—	—	—	—	—	—	6	6	8	8

Tightening torque: 0.5 to 0.8 N-m

The screw length behind the panel must be 9 mm maximum.

NC9Z-PW1 Marking Plate

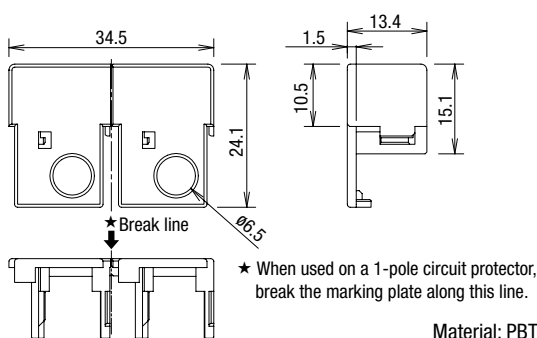

Marking Plate Installed on the Circuit Protector

When installed on a 2-pole circuit protector

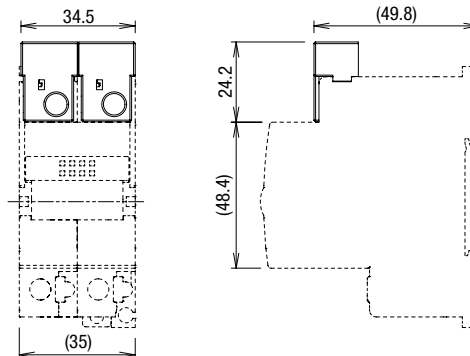

NC98-LK1 Padlock Attachment

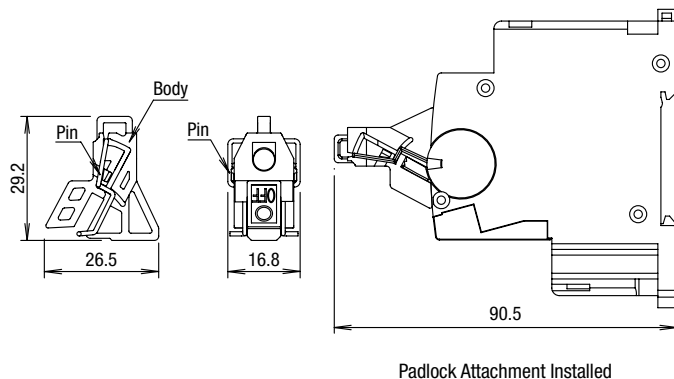

DIN Rail

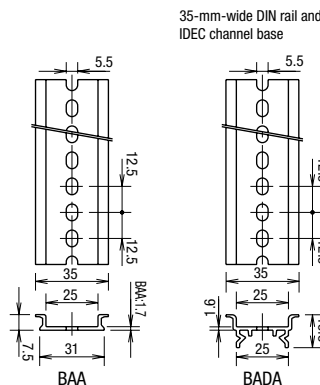

Replacement Parts

All dimensions in mm.

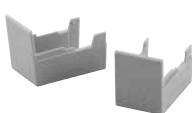
Shape	Material	Part No.	Ordering No.	Package Quantity	Remarks
	PA66	NC1V-AUX-CV	NC1V-AUX-CV	1	
Wiring Clip	Terminal: Brass Screw/washer: Steel	NC9Z-TA1	NC9Z-TA1PN10	10	

Instructions

Installation Angle

Tripping method is hydraulic magnetic. Minimum operating current varies with installation angle. Operating currents are influenced by the weight of movable iron core. With reference to the following figures, correct the rated current.

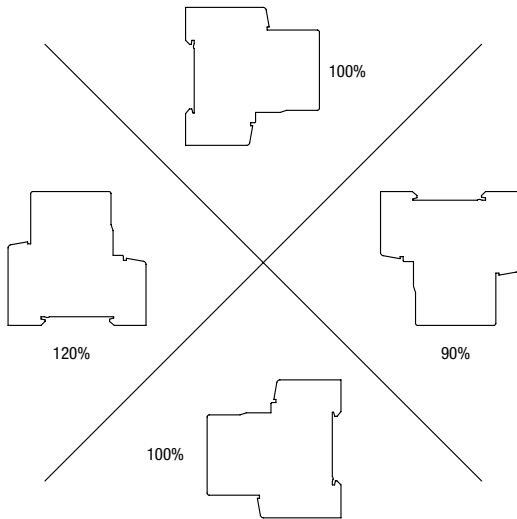

Minimum operating current is calculated from the following formula:
 (Minimum operating current) = (Rated current) × (Correction factor by installation angle) × (Reference minimum tripping current rate)

DIN Rails

[Installation on DIN Rail]

1. Fasten the DIN rail securely.
2. With the latch facing downward, install the NC1V circuit protector on the DIN rail as shown below.

[Removal from DIN Rail]

Using a flat screwdriver, pull the latch on the circuit protector to remove from the DIN rail.

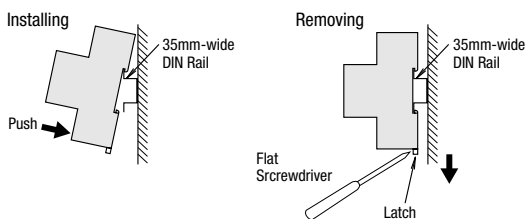

Applicable Wire and Crimp Terminal

Terminal	Terminal Screw	Connectable Wire Size (mm ²)	Applicable Crimping Terminal	Tightening Torque (N·m)
Main Circuit Terminals	Spring-up, fingersafe, slotted Phillips screw with square washer (up to 20A)	0.25 to 1.65	R1.25-4	1 to 1.4
		1.04 to 2.63	R2-4	
		2.63 to 6.64	R5.5-4	
	Spring-up fingersafe terminal (25A and 30A)	0.25 to 1.65	R1.25-5	1.8 to 2.2
1.04 to 2.63		R2-5		
2.63 to 6.64		R5.5-5		
Auxiliary Contact Alarm Contact Voltage Coil Terminals	Slotted Phillips screw with square washer	0.25 to 1.65	R1.25-3.5	0.7 to 0.9
		1.04 to 2.63	R2-3.5	

- For wiring the main circuit terminal, use the applicable crimp terminals and tighten to the recommended tightening torque.
- When using the NC1V circuit protector as CSA-certified product, use with CSA-certified crimp terminal.
- When using the NC1V circuit protector as UL-listed product, use with UL-listed crimp terminal.

Panel Mounting Screw (not supplied)

Screw Size	Tightening Torque	Shape
M4	0.8 to 1.0 N·m	 Spring Washer Plain Washer

Product Markings (Example: NC1V-1111-30AA)

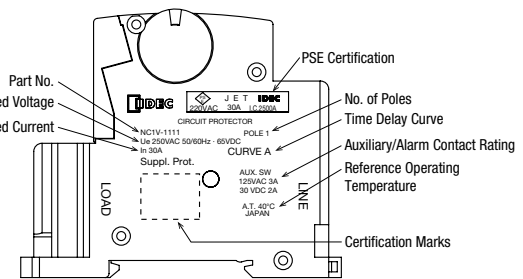

Installation of Auxiliary/Alarm Terminal Cover

After wiring the terminals, install the terminal cover by aligning the terminal cover with the circuit protector as shown below.

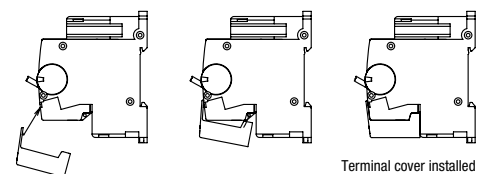

- APEM
- Switches & Pilot Lights
- Control Boxes
- Emergency Stop Switches
- Enabling Switches
- Safety Products
- Explosion Proof
- Terminal Blocks
- Relays & Sockets
- Circuit Protectors**
- Power Supplies
- LED Illumination
- Controllers
- Operator Interfaces
- Sensors
- AUTO-ID

Instructions

Installing Auxiliary/Alarm Terminal Cover

Connect the terminal before installing the terminal cover.

Installing

Attach the latch on TOP side and install the terminal cover as shown below.

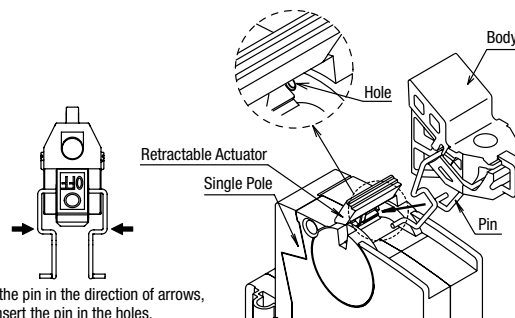
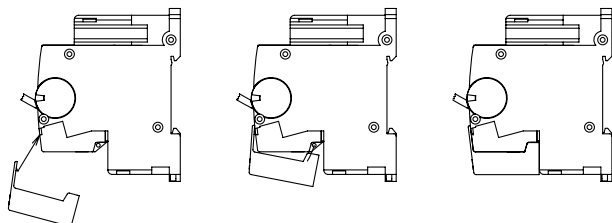

Push the pin in the direction of arrows, and insert the pin in the holes.

- ② Turn the body.
- ③ Install the body on the retractable actuator as shown below.
- ④ Slide the pin to the lock position.

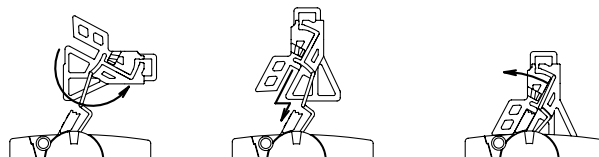

Installing NC9Z-MA Panel Mounting Brackets

1. Insert the wiring clip into the terminal of the circuit protector, and tighten.
 - Tightening torque to the main circuit terminal
 - 20A max. (M4): 1 to 1.4 N·m
 - 25A, 30A (M5): 1.8 to 2.2 N·m
2. Insert the panel mounting bracket to the circuit protector.
3. Install the rear of the panel mounting bracket into the DIN rail recess on the circuit protector and push in the clamp.

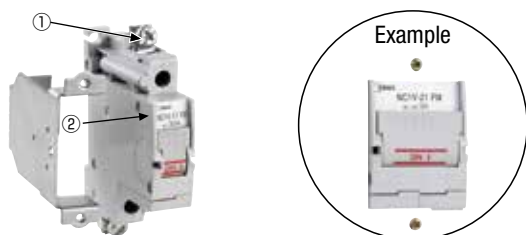

Note: NC1V circuit protectors with auxiliary/alarm contacts cannot be used with mounting brackets.

Padlock

- The padlock is not supplied with the padlock attachment and must be supplied by the user.
- The total weight of the padlock can be a maximum of 45g. Make sure the padlock weight does not exceed 45g, otherwise the NC1V circuit protector may be damaged.
- Applicable Padlock Size

(A)	(B)	C	D	E	(F)	G
19 to 25	35 to 42	9 to 11.5	4 to 4.5	11 to 15	8 to 10	7.5 to 9.0

Note: (A) (B) (F) are for reference only.

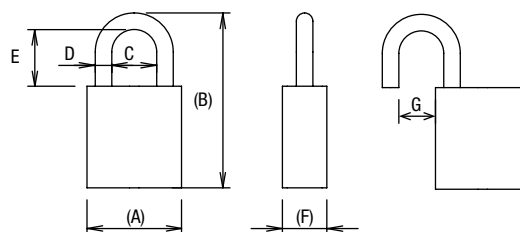

Recommended Padlock

Manufacturer	Part No.
Alpha	1000-25
Master Lock	4120

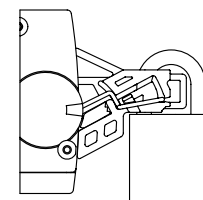

Installing the NC98-PW1 Marking Plate

Available for 2-pole circuit protectors only.
For use on 1-pole circuit protectors, break the marking plate into two halves.

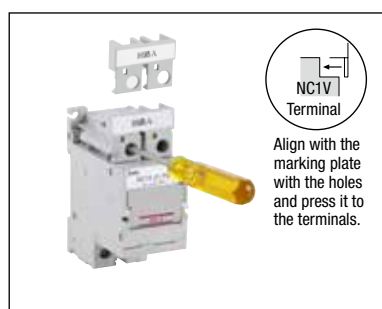

Marking Range

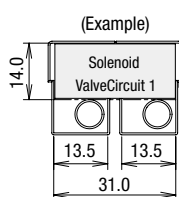

Installing the NC98-LK1 Padlock Attachment

- ① Pull down the retractable actuator, and install the padlock attachment on the circuit protector.
 - 1-pole: Insert the pin into the holes under the retractable actuator.
 - 2- or 3-pole: Insert the pin into the holes in the center of the circuit protector.

Safety Precautions

- When using the padlock, do not use the NC1V circuit protector where it is subject to vibration or shock, otherwise failure or damage may result.
- Do not apply a force of more than 50N on the retractable actuator, otherwise the actuator will be damaged.
- When using three or more 1-pole NC1V circuit protectors adjacently, facilitate installing the padlock attachment by providing a clearance of 6mm minimum between the protectors, or by using the tweezers or flat screwdriver

Ordering Terms and Conditions

Thank you for using IDEC Products.

By purchasing products listed in our catalogs, datasheets, and the like (hereinafter referred to as "Catalogs") you agree to be bound by these terms and conditions. Please read and agree to the terms and conditions before placing your order.

1. Notes on contents of Catalogs

- (1) Rated values, performance values, and specification values of IDEC products listed in this Catalog are values acquired under respective conditions in independent testing, and do not guarantee values gained in combined conditions.
Also, durability varies depending on the usage environment and usage conditions.
- (2) Reference data and reference values listed in Catalogs are for reference purposes only, and do not guarantee that the product will always operate appropriately in that range.
- (3) The specifications / appearance and accessories of IDEC products listed in Catalogs are subject to change or termination of sales without notice, for improvement or other reasons.
- (4) The content of Catalogs is subject to change without notice.

2. Note on applications

- (1) If using IDEC products in combination with other products, confirm the applicable laws / regulations and standards.
Also, confirm that IDEC products are compatible with your systems, machines, devices, and the like by using under the actual conditions. IDEC shall bear no liability whatsoever regarding the compatibility with IDEC products.
- (2) The usage examples and application examples listed in Catalogs are for reference purposes only. Therefore, when introducing a product, confirm the performance and safety of the instruments, devices, and the like before use. Furthermore, regarding these examples, IDEC does not grant license to use IDEC products to you, and IDEC offers no warranties regarding the ownership of intellectual property rights or non-infringement upon the intellectual property rights of third parties.
- (3) When using IDEC products, be cautious when implementing the following.
 - i. Use of IDEC products with sufficient allowance for rating and performance
 - ii. Safety design, including redundant design and malfunction prevention design that prevents other danger and damage even in the event that an IDEC product fails
 - iii. Wiring and installation that ensures the IDEC product used in your system, machine, device, or the like can perform and function according to its specifications
- (4) Continuing to use an IDEC product even after the performance has deteriorated can result in abnormal heat, smoke, fires, and the like due to insulation deterioration or the like. Perform periodic maintenance for IDEC products and the systems, machines, devices, and the like in which they are used.
- (5) IDEC products are developed and manufactured as general-purpose products for general industrial products. They are not intended for use in the following applications, and in the event that you use an IDEC product for these applications, unless otherwise agreed upon between you and IDEC, IDEC shall provide no guarantees whatsoever regarding IDEC products.
 - i. Use in applications that require a high degree of safety, including nuclear power control equipment, transportation equipment (railroads / airplanes / ships / vehicles / vehicle instruments, etc.), equipment for use in outer space, elevating equipment, medical instruments, safety devices, or any other equipment, instruments, or the like that could endanger life or human health
 - ii. Use in applications that require a high degree of reliability, such as provision systems for gas / waterworks / electricity, etc., systems that operate continuously for 24 hours, and settlement systems
 - iii. Use in applications where the product may be handled or used deviating from the specifications or conditions / environment listed in the Catalogs, such as equipment used outdoors or applications in environments subject to chemical pollution or electromagnetic interference
If you would like to use IDEC products in the above applications, be sure to consult with an IDEC sales representative.

3. Inspections

We ask that you implement inspections for IDEC products you purchase without delay, as well as thoroughly keep in mind management/maintenance regarding handling of the product before and during the inspection.

4. Warranty

- (1) Warranty period
The warranty period for IDEC products shall be one (1) year after purchase or delivery to the specified location. However, this shall not apply in cases where there is a different specification in the Catalogs or there is another agreement in place between you and IDEC.
- (2) Warranty scope
Should a failure occur in an IDEC product during the above warranty period for reasons attributable to IDEC, then IDEC shall replace or repair that product, free of charge, at the purchase location / delivery location of the product, or an IDEC service base. However, failures caused by the following reasons shall be deemed outside the scope of this warranty.
 - i. The product was handled or used deviating from the conditions / environment listed in the Catalogs
 - ii. The failure was caused by reasons other than an IDEC product
 - iii. Modification or repair was performed by a party other than IDEC
 - iv. The failure was caused by a software program of a party other than IDEC
 - v. The product was used outside of its original purpose
 - vi. Replacement of maintenance parts, installation of accessories, or the like was not performed properly in accordance with the user's manual and Catalogs
 - vii. The failure could not have been predicted with the scientific and technical standards at the time when the product was shipped from IDEC
 - viii. The failure was due to other causes not attributable to IDEC (including cases of force majeure such as natural disasters and other disasters)Furthermore, the warranty described here refers to a warranty on the IDEC product as a unit, and damages induced by the failure of an IDEC product are excluded from this warranty.

5. Limitation of liability

The warranty listed in this Agreement is the full and complete warranty for IDEC products, and IDEC shall bear no liability whatsoever regarding special damages, indirect damages, incidental damages, or passive damages that occurred due to an IDEC product.

6. Service scope

The prices of IDEC products do not include the cost of services, such as dispatching technicians. Therefore, separate fees are required in the following cases.

- (1) Instructions for installation / adjustment and accompaniment at test operation (including creating application software and testing operation, etc.)
- (2) Maintenance inspections, adjustments, and repairs
- (3) Technical instructions and technical training
- (4) Product tests or inspections specified by you

The above content assumes transactions and usage within your region. Please consult with an IDEC sales representative regarding transactions and usage outside of your region. Also, IDEC provides no guarantees whatsoever regarding IDEC products sold outside your region.

IDEC CORPORATION

Head Office 6-64, Nishi-Miyahara-2-Chome, Yodogawa-ku, Osaka 532-0004, Japan

 www.idec.com

USA IDEC Corporation
EMEA APEM SAS

Singapore IDEC Izumi Asia Pte. Ltd.
Thailand IDEC Asia (Thailand) Co., Ltd.
India IDEC Controls India Private Ltd.

China IDEC (Shanghai) Corporation
IDEC Izumi (H.K.) Co., Ltd.
Taiwan IDEC Taiwan Corporation

Japan IDEC Corporation

Specifications and other descriptions in this brochure are subject to change without notice.
Information in this brochure is current as of June, 2021.
2021 IDEC Corporation, All Rights Reserved.

