

3-phase inverter based on STSPIN32F0601Q with 3-shunt topology

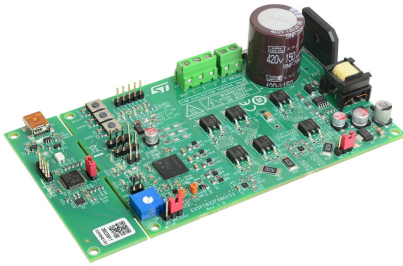

Features

- Input voltage from 35 V_{AC} (50 V_{DC}) to 280 V_{AC} (400 V_{DC})
- Suitable for applications up to 300 W
- STGD6M65DF2 IGBTs power stage featuring:
 - $V_{(BR)CES} = 650 \text{ V}$
 - $V_{CE(sat)} = 1.55 \text{ V @ } I_C = 6 \text{ A}$
- Overcurrent threshold set to 4.5 A_{peak}
- Dual footprint for IGBT/MOSFET package:
 - DPAK or PowerFlat 8x8 HV
- 3-shunt current sensing, suitable for: sensed or sensorless vector control - FOC algorithm with 3-shunt sensing
- Smart shutdown overcurrent protection
- Digital Hall sensors and encoder input
- Bus voltage sensing
- 15 V VCC and 3.3 V VDD supplies
- Embedded ST-LINK/V2-1
- Easy user interface with buttons and trimmer
- RoHS compliant

Applications

- Home and Industrial refrigerator compressors
- Industrial drives, pumps, fans
- Air conditioning compressors & fans
- Corded power tools, garden tools
- Home appliances
- Industrial automation



Product status link

EVSPIN32F06Q1S3

Description

The EVSPIN32F06Q1S3 board is a 3-phase complete inverter based on the STSPIN32F0601 controller, QFN 72L package version, which embeds a 3-phase 600 V gate driver and a Cortex[®]-M0 STM32 MCU. The power stage features STGD6M65DF2 IGBTs, but can be populated with any IGBT or Power MOSFET in DPAK or powerFLAT 8x8 HV package. The board has a 3-shunt sensing topology, and the field-oriented control (FOC), either sensed or sensorless, can be implemented. This makes it especially suited to drive permanent magnet synchronous motors (PMSMs).

The evaluation board is compatible with a wide range input voltage from 35 V_{AC} (50 V_{DC}) to 280 V_{AC} (400 V_{DC}), and includes a power supply stage with the VIPER06XS in flyback configuration to generate +15 V and +3.3 V supply voltage required by the application.

Debug and configuration of FW can be performed with standard STM32 tools through the detachable STLINK-debugger. SWD and UART TX-RX connectors are also available.

1 Safety and operating instructions



1.1 General terms

Warning:

During assembly, testing, and operation, the evaluation board poses several inherent hazards, including bare wires, moving or rotating parts and hot surfaces.

Danger:

There is danger of serious personal injury, property damage or death due to electrical shock and burn hazards if the kit or components are improperly used or installed incorrectly.

The kit is not electrically isolated from the high-voltage supply AC/DC input. The evaluation board is directly linked to the mains voltage. No insulation is ensured between the accessible parts and the high voltage. All measuring equipment must be isolated from the mains before powering the board. When using an oscilloscope with the demo, it must be isolated from the AC line. This prevents shock from occurring as a result of touching any single point in the circuit, but does NOT prevent shock when touching two or more points in the circuit.

All operations involving transportation, installation and use, and maintenance must be performed by skilled technical personnel able to understand and implement national accident prevention regulations. For the purposes of these basic safety instructions, "skilled technical personnel" are suitably qualified people who are familiar with the installation, use and maintenance of power electronic systems.

1.2 Intended use of evaluation board

The evaluation board is designed for demonstration purposes only, and must not be used for electrical installations or machinery. Technical data and information concerning the power supply conditions are detailed in the documentation and should be strictly observed.

1.3 Installing the evaluation board

- The installation and cooling of the evaluation board must be in accordance with the specifications and target application.
- The motor drive converters must be protected against excessive strain. In particular, components should not be bent or isolating distances altered during transportation or handling.
- No contact must be made with other electronic components and contacts.
- The board contains electrostatically-sensitive components that are prone to damage if used incorrectly. Do not mechanically damage or destroy the electrical components (potential health risks).

1.4 Operating the evaluation board

To operate properly the board, follow these safety rules.

1. Work Area Safety:

- The work area must be clean and tidy.
- Do not work alone when boards are energized.
- Protect against inadvertent access to the area where the board is energized using suitable barriers and signs.
- A system architecture that supplies power to the evaluation board must be equipped with additional control and protective devices in accordance with the applicable safety requirements (i.e., compliance with technical equipment and accident prevention rules).
- Use non-conductive and stable work surface.
- Use adequately insulated clamps and wires to attach measurement probes and instruments.

2. Electrical Safety:

- Remove power supply from the board and electrical loads before performing any electrical measurement.
- Proceed with the arrangement of measurement setup, wiring or configuration paying attention to high-voltage sections.
- Once the setup is complete, energize the board.

Danger:

Do not touch the evaluation board when it is energized or immediately after it has been disconnected from the voltage supply as several parts and power terminals containing potentially energized capacitors need time to discharge.

Do not touch the boards after disconnection from the voltage supply as several parts like heat sinks and transformers may still be very hot.

The kit is not electrically isolated from the AC/DC input. The USB interface of the board does not insulate host computer from high voltage. When the board is supplied at a voltage outside the ELV range, a proper insulation method such as a USB isolator must be used to operate the board.

3. Personal Safety

- Always wear suitable personal protective equipment such as insulating gloves and safety glasses.
- Take adequate precautions and install the board in such a way to prevent accidental touch. Use protective shields such as, for example, insulating box with interlocks if necessary.

2 Schematic diagram

Figure 1. EVSPIN32F06Q1S3 schematic – Driver output stages

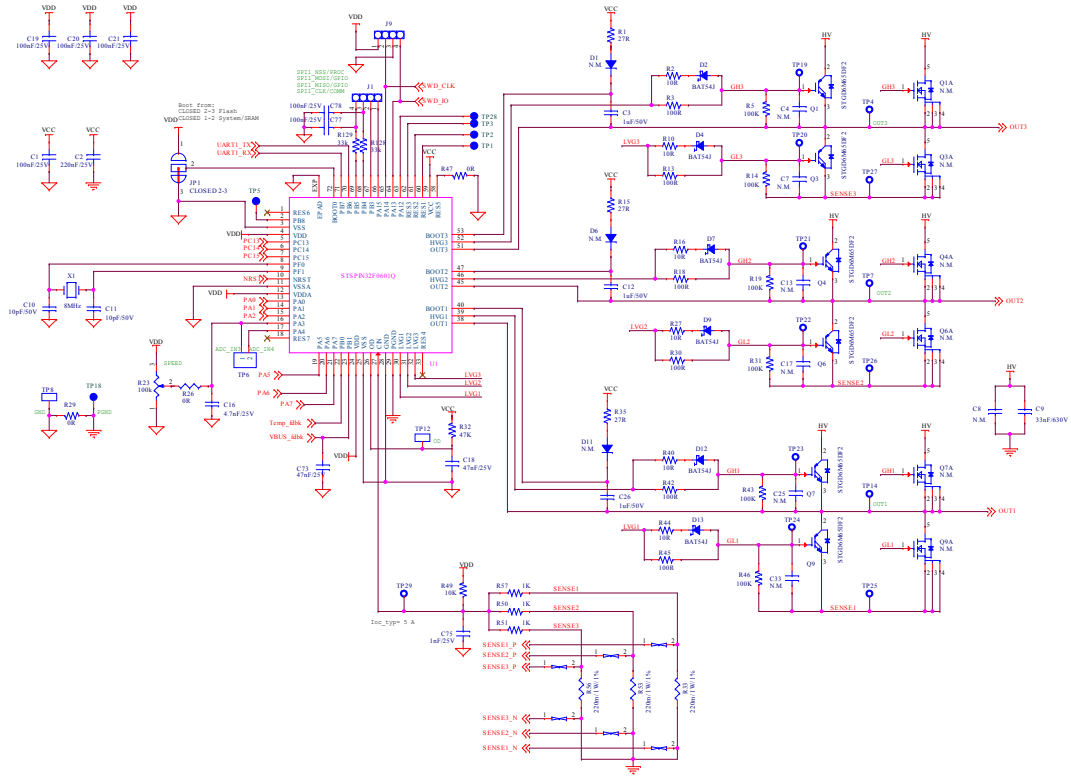

Figure 2. EVSPIN32F06Q1S3 schematic – Feedback network

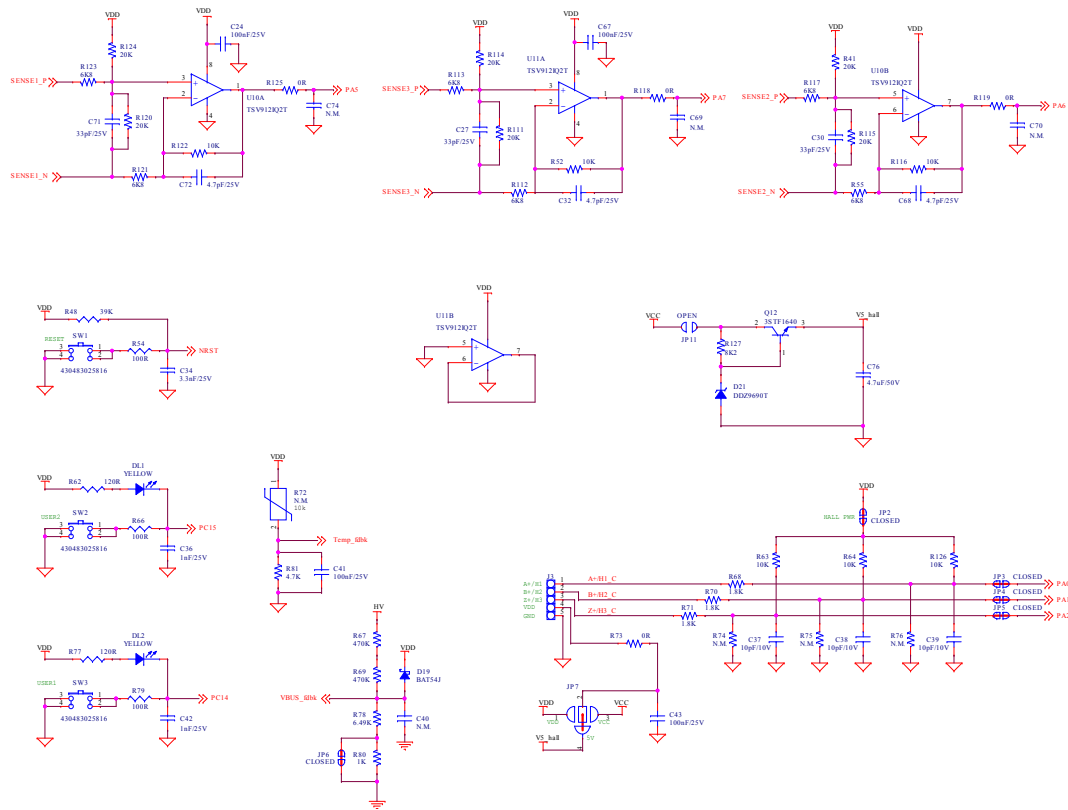

Figure 3. EVSPIN32F06Q1S3 schematic – Power Supply

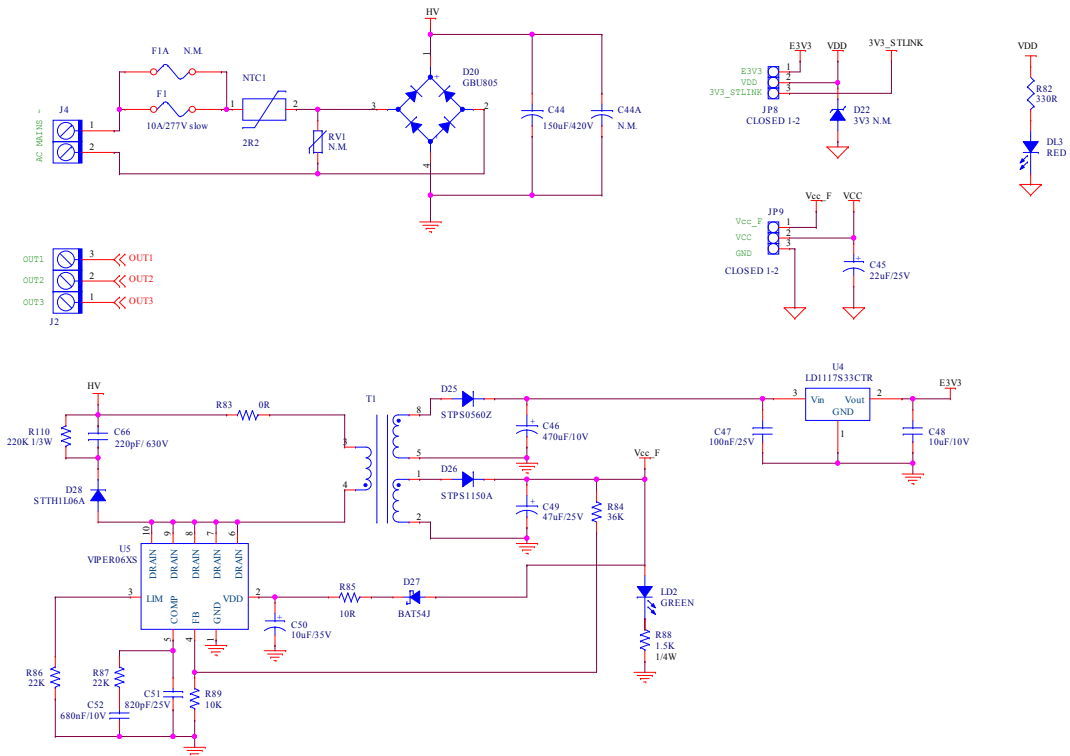
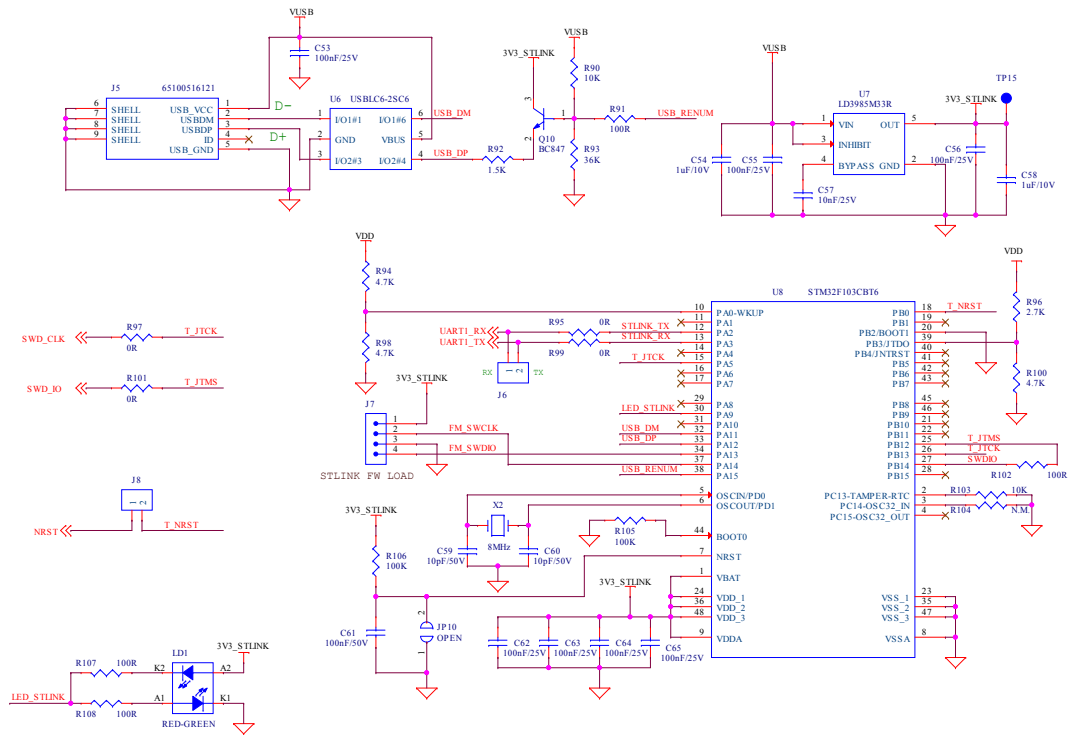

Figure 4. EVSPIN32F06Q1S3 schematic – STLINK debugger



3 Bill of Material

Table 1. Bill of Materials – Components common to all device variants

Reference	Part Value	Description	Package	Manufacturer	Part Number
C1,C19,C20, C21,C24,C41, C43,C47,C53, C55,C56,C62, C63,C64,C65, C67,C77,C78	100nF/25V	SMT ceramic capacitor	Size 0603	Würth Elektronik	885012206071 or equivalent
C2	220nF/25V	SMT ceramic capacitor	Size 0603	Würth Elektronik	885012106019 or equivalent
C3,C12,C26	1uF/50V	SMT ceramic capacitor	Size 0805	Würth Elektronik	885012207103 or equivalent
C4,C7,C13, C17,C25,C33, C40,C69,C70, C74	N.M.	SMT ceramic capacitor	Size 0603		
C8	N.M.	Film, metallized polypropylene	5x13 mm, Pitch 10 mm	Würth Elektronik	890283423001 or equivalent
or C9	33nF/630V	SMT ceramic capacitor	Size 1210	Würth Elektronik	885342209004 or equivalent
C10,C11,C59, C60	10pF/50V	SMT ceramic capacitor	Size 0603	Würth Elektronik	885012006051 or equivalent
C16	4.7nF/25V	SMT ceramic capacitor	Size 0603	Würth Elektronik	885012206063 or equivalent
C18,C73	47nF/25V	SMT ceramic capacitor	Size 0603	Würth Elektronik	885012206069 or equivalent
C27,C30,C71	33pF/25V	SMT ceramic capacitor	Size 0603	Würth Elektronik	885012006035 or equivalent
C32,C68,C72	4.7pF/25V	SMT ceramic capacitor	Size 0603	Würth Elektronik	885012006030 or equivalent
C34	3.3nF/25V	SMT ceramic capacitor	Size 0603	Würth Elektronik	885012206062 or equivalent
C36,C42,C75	1nF/25V	SMT ceramic capacitor	Size 0603	Würth Elektronik	885012206059 or equivalent
C37,C38,C39	10pF/10V	SMT ceramic capacitor	Size 0603	Würth Elektronik	885012006002 or equivalent
C44	150uF/420V	THT electrolytic capacitor, radial p10 d22h27 105C	Radial p10 d22h27.5 mm	United Chemi-Con	EKMZ421VSN151MP25S or equivalent
C44A	N.M.	THT electrolytic capacitor, radial p7.5 d18h25	Radial p7.5 d18h25 mm	Rubycon	450BXW68MEFC18X25 or equivalent
C45	22uF/25V	SMT aluminum elect. capacitor	5x5.4 mm	Würth Elektronik	865090442004 or equivalent
C46	470uF/10V	SMT aluminum elect. capacitor	6.3x7.7 mm	Panasonic	EEEFTA471XAP or equivalent
C48	10uF/10V	SMT ceramic capacitor	Size 1206	Würth Elektronik	885012208018 or equivalent

Reference	Part Value	Description	Package	Manufacturer	Part Number
C49	47uF/25V	SMT aluminum elect. capacitor	6.3x5.8 mm	Würth Elektronik	865060443004 or equivalent
C50	10uF/35V	SMT aluminum elect. capacitor	5x5.4 mm	Würth Elektronik	865230542002 or equivalent
C51	820pF/25V	SMT ceramic capacitor	Size 0603		
C52	680nF/10V	SMT ceramic capacitor	Size 0603	Würth Elektronik	885012206025 or equivalent
C54,C58	1uF/10V	SMT ceramic capacitor	Size 0603	Würth Elektronik	885012206026 or equivalent
C57	10nF/25V	SMT ceramic capacitor	Size 0603	Würth Elektronik	885012206065 or equivalent
C61	100nF/50V	SMT ceramic capacitor	Size 0603	Würth Elektronik	885012206095 or equivalent
C66	220pF/630V	SMT ceramic capacitor	Size 1206	Multicomp	MC1206N221J631CT or equivalent
C76	4.7uF/50V	SMT ceramic capacitor	Size 1206	Würth Elektronik	885012208094 or equivalent
DL1,DL2	Yellow	Yellow LED	Size 0603	Würth Elektronik	150060YS75000 or equivalent
DL3	Red	Red LED	Size 0603	Würth Elektronik	150060RS75000 or equivalent
D1,D6,D11	N.M.	Turbo 2 ultrafast high-voltage Rectifier	SMA	STMicroelectronics	STTH1L06A or equivalent
D2,D4,D7, D9,D12,D13, D19,D27	BAT54J	40V, 300mA small signal Schottky SMT Diode	SOD-323	STMicroelectronics	BAT54JFILM or equivalent
D20	GBU805	8A glass passivated single-phase bridge rectifier	GBU	Taiwan Semiconductor or Diodes Incorporated	GBU805 or GBU806
D21	DDZ9690T	Surface mount Zener diode	SOD523	Diodes Incorporated	DDZ9690T-7 or equivalent
D22	3V3 N.M.	Zener	SOD-123		
D25	STPS0560Z	60V, 0.5A Schottky rectifier	SOD-123	STMicroelectronics	STPS0560Z or equivalent
D26	STPS1150A	150V, 1A power Schottky rectifier	SMA	STMicroelectronics	STPS1150A or equivalent
D28	STTH1L06A	Turbo 2 ultrafast high-voltage rectifier	SMA	STMicroelectronics	STTH1L06A or equivalent
F1A	N.M.	Time lag radial lead micro fuse, 250Vac	RST-Belfuse	Bel Fuse	0697-xx or equivalent
F1	10A/277V slow	Surface mount fuse, time lag T, 250Vac 125Vdc	UMT250-Shurter	Schurter	3403.0176.24 or equivalent
JP1	Closed 2-3	SMT jumper	Soldering pad		
JP2,JP3,JP4, JP5,JP6	Closed	SMT jumper	Soldering pad		
JP7	Closed 2-4	Jumper to solder	Soldering pads		
JP8,JP9	Closed 1-2	Strip connector 3 pos, 2.54 mm	1x3 pins	Würth Elektronik	61300311121 or equivalent
JP10	Open	SMT jumper	Size 0805		
JP11	Open	SMT jumper			
JP13,JP14,JP15	N.M.				

Reference	Part Value	Description	Package	Manufacturer	Part Number
J1,J7,J9	STRIP 1x4	Strip connector 4 pos, 2.54 mm	1x4 pins	Würth Elektronik	61300411121 or equivalent
J2	MORSV-508-3 P_screw	Connector terminal block T.H. 3 positions 5.08 mm	3 poles, pitch 5.08	Würth Elektronik	691213510003 or equivalent
J3	STRIP 1x5	Strip connector 5 pos, 2.54 mm	1x5 pins	Würth Elektronik	61300511121 or equivalent
J4	MORSV-508-2 P_screw	Connector terminal block T.H. 2 positions 5.08 mm	2 poles, pitch 5.08	Würth Elektronik	691213510002 or equivalent
J5	65100516121	Mini USB 2.0 type B SMD	USB mini B	Würth Elektronik	65100516121 or equivalent
TP6,J6,J8	STRIP 1x2	Strip connector 2 pos, 2.54 mm	1x2 pins	Würth Elektronik	61300211121 or equivalent
LD1	Red-Green	LED indicators,PLCC-4 Red / Yellow / Green	PLCC 4	AVAGO	HSMF-A201-A00J1
LD2	Green	Green LED	Size 0805	Würth Elektronik	150080GS75000 or equivalent
NTC1	2R2	NTC thermistor for inrush current limiting		TDK	B57236S0229M000 or equivalent
Q1A,Q3A,Q4A, Q6A,Q7A,Q9A	N.M.	N-channel 600V, 0.195 Ohm typ., 15 A MDmesh DM2 power MOSFET	PowerFLAT 8x8	STMicroelectronics	STL24N60DM2 or equivalent
Q1,Q3,Q4, Q6,Q7,Q9	STGD6M65DF 2	Trench gate field-stop IGBT, M series 650V, 6A low loss	DPAK	STMicroelectronics	STGD6M65DF2 or equivalent
Q10	BC847	General Purpose_45V_100mA_225mW	SOT23	ON Semiconductor	BC847BL or equivalent
Q12	3STF1640	Low voltage high performance NPN power transistor	SOT-89	STMicroelectronics	3STF1640 or equivalent
RV1	N.M.	Varistor	Pitch 2.3x7.5 mm		
R1,R15,R35	27R	SMT resistor	Size 0805		
R2,R10,R16, R27,R40,R44	10R	SMT resistor	Size 0805		
R3,R13,R18, R30,R42,R45	100R	SMT resistor	Size 0805		
R5,R14,R19, R31,R43,R46, R105,R106	100k	SMT resistor	Size 0603		
R23	100k	Square trimpot trimming potentiometer	3386P	Bourns	3386P-1-104-LF or equivalent
R26,R29,R73, R95,R97,R99, R101,R118,R119, R125	0R	SMT resistor	Size 0603		
R32	47k	SMT resistor	Size 0603		
R33,R53,R56	220m/ 1W/ 1%	SMT resistor	Size 2512 / 1210		
R41,R111,R114, R115,R120,R124	20k	SMT resistor	Size 0603		
R47	0R	SMT resistor	Size 0603		
R48	39k	SMT resistor	Size 0603		

Reference	Part Value	Description	Package	Manufacturer	Part Number
R49,R52,R63, R64,R89,R90, R103,R116,R122, R126	10k	SMT resistor	Size 0603		
R50,R51,R57	1k	SMT resistor	Size 0603		
R54,R66,R79, R91,R102,R107, R108	100R	SMT resistor	Size 0603		
R55,R112,R113, R117,R121,R123	6k8	SMT resistor	Size 0603		
R62,R77	120R	SMT resistor	Size 0603		
R67,R69	470k	SMT resistor	Size 1206		
R68,R70,R71	1.8k	SMT resistor	Size 0603		
R72	N.M.	NTC resistor	Hole 0.8 mm		
R74,R75,R76, R104	N.M.	SMT resistor	Size 0603		
R78	6.49k	SMT resistor	Size 0805		
R80	1k	SMT resistor	Size 0805		
R81,R94,R98, R100	4.7k	SMT resistor	Size 0603		
R82	330R	SMT resistor	Size 0603		
R83	0R	SMT resistor	Size 1206		
R84,R93	36k	SMT resistor	Size 0603		
R85	10R	SMT resistor	Size 0603		
R86,R87	22k	SMT resistor	Size 0603		
R88	1.5k	SMT resistor	Size 1206		
R92	1.5k	SMT resistor	Size 0603		
R96	2.7k	SMT resistor	Size 0603		
R110	220K 1/3W	SMT resistor	Size 0805	TE Connectivity	CRGH0805J220K or equivalent
R127	8k2	SMT resistor	Size 0603		
R128,R129	33k	SMT resistor	Size 0603		
SW1,SW2,SW3	430483025816	CMS tactile switches - 6x6 J-bend		Würth Elektronik	430483025816 or equivalent
TP1	TPHIN1	Test point, PCB 1mm diameter	Copper pad		
TP2	TPHIN2	Test point, PCB 1mm diameter	Copper pad		
TP3	TPHIN3	Test point, PCB 1mm diameter	Copper pad		
TP4,TP7,TP14, TP19,TP20,TP21, TP22,TP23,TP24, TP25,TP26,TP27, TP29	N.M.	TP for probe	Diam. 1.27, hole 0.8mm		

Reference	Part Value	Description	Package	Manufacturer	Part Number
TP5	PB8	Test point, PCB 1mm diameter	Copper pad		
TP8,TP12	TPTH-ANELLO-1mm	THT ring test point		Keystone	5003 or equivalent
TP15	NEEDLE-PAD-1.7mm	Test point - PCB 1.7mm diameter	Copper pad		
TP18	PGND	Test point, PCB 1mm diameter	Copper pad		
TP28	PA12	Test point, PCB 1mm diameter	Copper pad		
T1	750318434	Switch mode transformer 2.3W 60kHz 3.15mH 7-15V		Würth Elektronik	750318434
U1	STSPIN32F0601Q	600V 3-phase controller with ARM Cortex MCU	QFN72-10X10	STMicroelectronics	STSPIN32F0601Q/TR
U4	LD1117S33CTR	800mA, 3.3V Adjustable and Fixed low drop positive Voltage Regulator	SOT-223	STMicroelectronics	LD1117S33CTR or equivalent
U5	VIPER06XS	Fixed-frequency VIPer plus family	SSO10	STMicroelectronics	VIPER06XS
U6	USBLC6-2SC6	Very low capacitance ESD protection	SOT23-6L	STMicroelectronics	USBLC6-2SC6 / Y or equivalent
U7	LD3985M33R	3.3V_150mA_ultra low drop Voltage Regulator	SOT23-5L	STMicroelectronics	LD3985M33R or equivalent
U8	STM32F103C BT6	64/182KB flash_USB_72MHz_3.6V	LQFP48 - 7x7 mm	STMicroelectronics	STM32F103CBT6
U10,U11	TSV912IQ2T	Dual rail-to-rail input/output 8 MHz operational amplifiers	DFN8 2x2	STMicroelectronics	TSV912IQ2T or equivalent
X1,X2	8MHz	Crystal 8.0000MHZ 8PF SMD	2.5x3.2 mm	NDK	NX3225GD-8MHZ-STD-CRA-3 or equivalent
		Rubber feet		Hammond	1421T6CL or equivalent
J8,JP8,JP9		Female jumper isolated, pitch 2.54mm		Assmann WSW	AKSCT/Z BLACK or equivalent
		P.C.B. EVSPIN32F06Q1S3 Rev.1.0		STMicroelectronics	

4 Layout and component placements

Figure 5. EVSPIN32F06Q1S3 – Board functions description

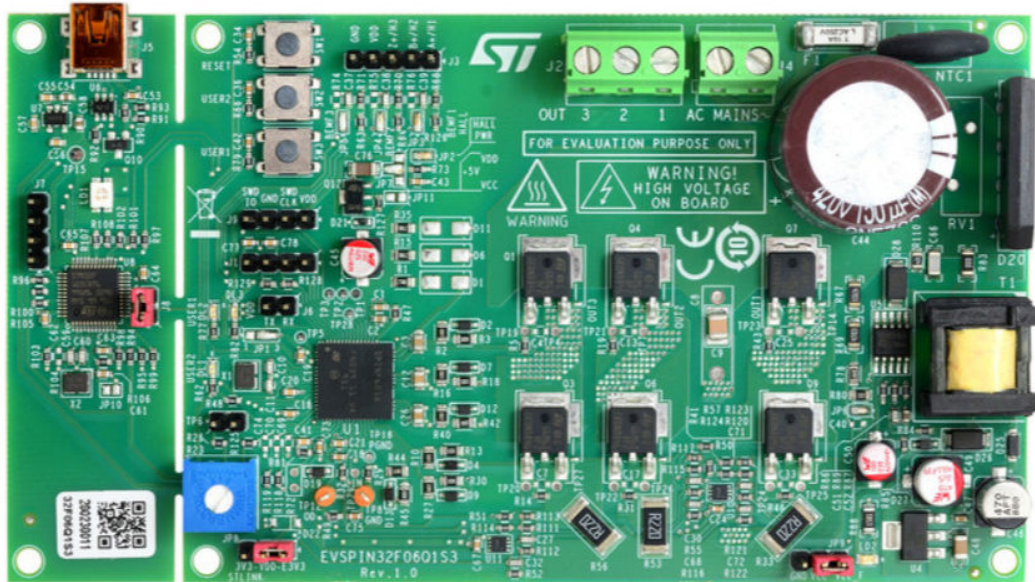

Warning:

The kit is not electrically isolated from the AC/DC input. The USB interface of the board does not insulate host computer from high voltage. When the board is supplied at a voltage outside the ELV range, a proper insulation method such as a USB isolator must be used to operate the board.

Figure 6. EVSPIN32F06Q1S3 – Layout (component placement top view)

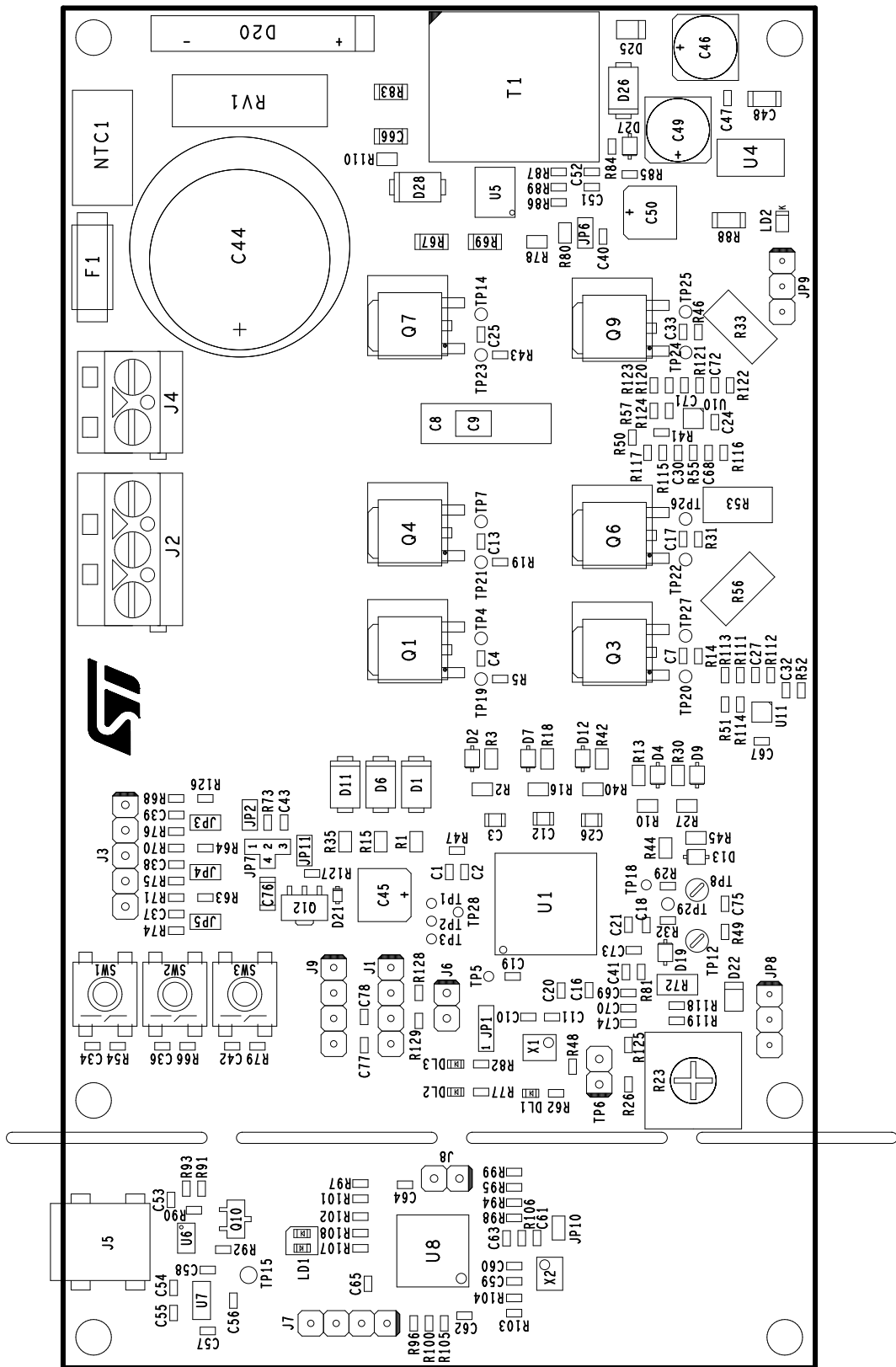

Figure 7. EVSPIN32F06Q1S3 – Layout (top layer)

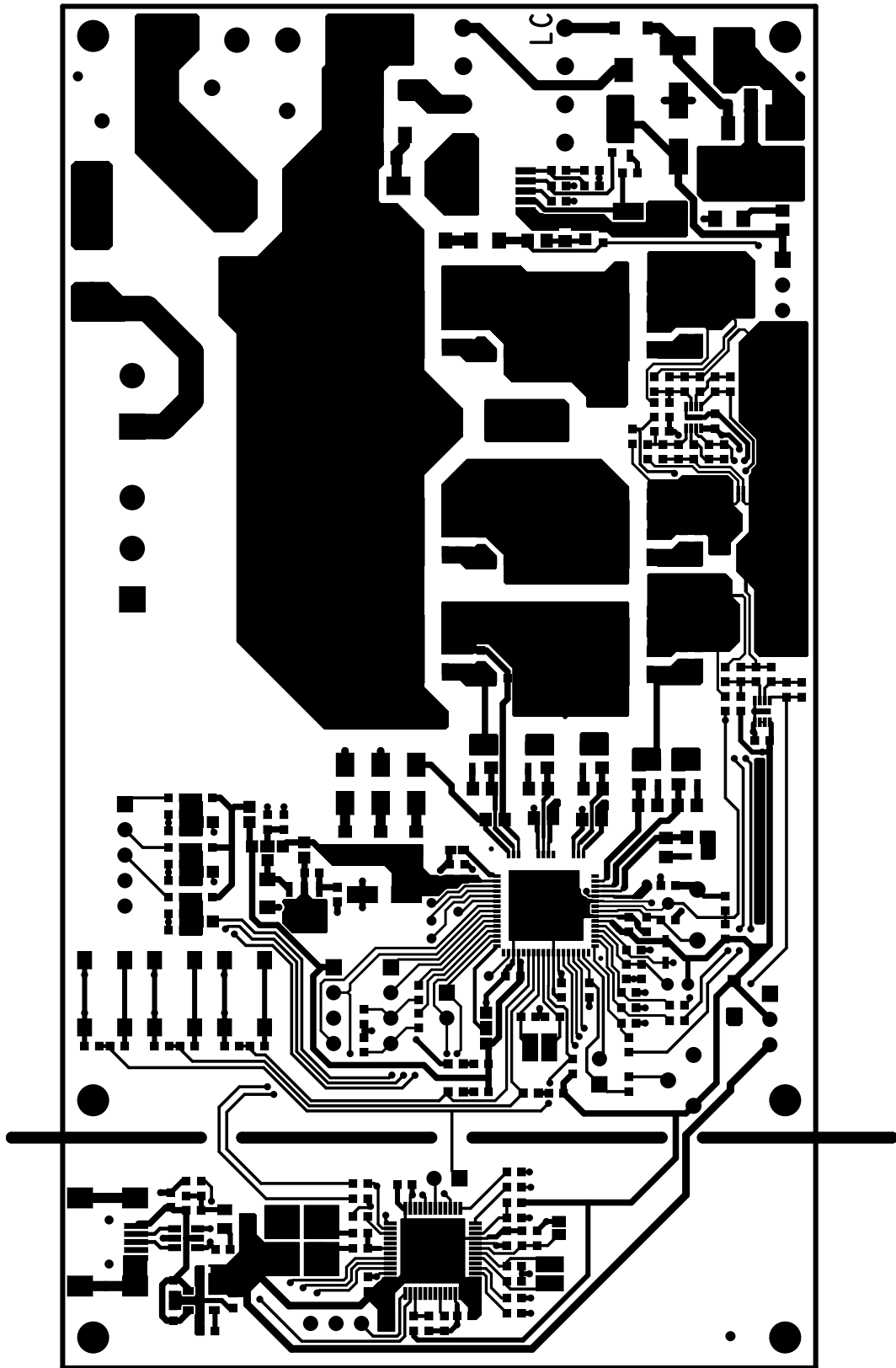
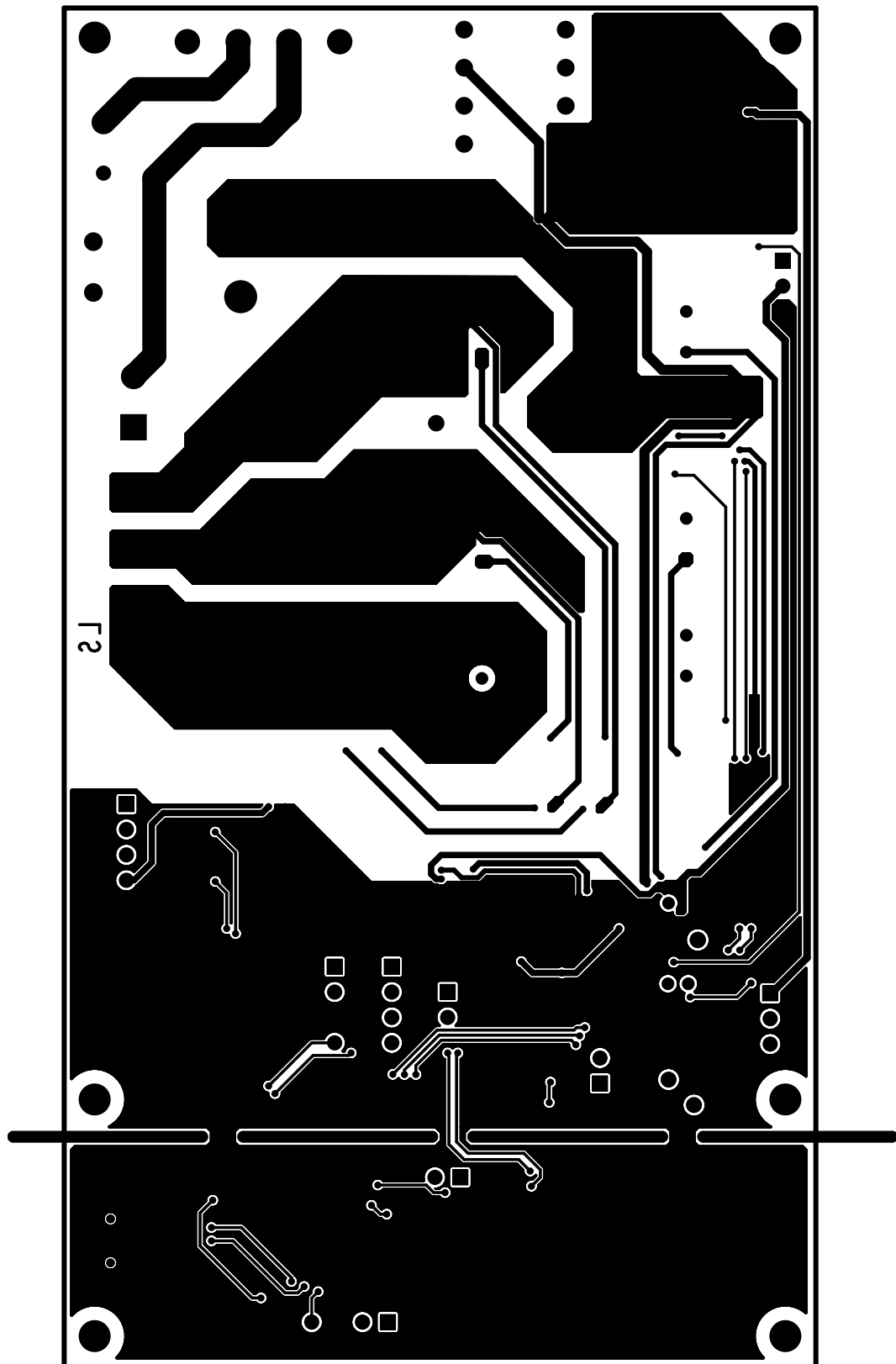

Figure 8. EVSPIN32F06Q1S3 – Layout (bottom layer)



Revision history

Table 2. Document revision history

Date	Version	Changes
09-Nov-2020	1	Initial release.
30-Jun-2023	2	Added board maximum power in Section Features

Contents

1	Safety and operating instructions	2
1.1	General terms	2
1.2	Intended use of evaluation board	2
1.3	Installing the evaluation board	2
1.4	Operating the evaluation board	2
2	Schematic diagram	4
3	Bill of Material	7
4	Layout and component placements	12
	Revision history	16
	Contents	17
	List of tables	18
	List of figures	19



List of tables

Table 1.	Bill of Materials – Components common to all device variants	7
Table 2.	Document revision history	16

List of figures

Figure 1.	EVSPIN32F06Q1S3 schematic – Driver output stages	4
Figure 2.	EVSPIN32F06Q1S3 schematic – Feedback network	5
Figure 3.	EVSPIN32F06Q1S3 schematic – Power Supply	5
Figure 4.	EVSPIN32F06Q1S3 schematic – STLINK debugger	6
Figure 5.	EVSPIN32F06Q1S3 – Board functions description	12
Figure 6.	EVSPIN32F06Q1S3 – Layout (component placement top view)	13
Figure 7.	EVSPIN32F06Q1S3 – Layout (top layer)	14
Figure 8.	EVSPIN32F06Q1S3 – Layout (bottom layer)	15

IMPORTANT NOTICE – READ CAREFULLY

STMicroelectronics NV and its subsidiaries (“ST”) reserve the right to make changes, corrections, enhancements, modifications, and improvements to ST products and/or to this document at any time without notice. Purchasers should obtain the latest relevant information on ST products before placing orders. ST products are sold pursuant to ST’s terms and conditions of sale in place at the time of order acknowledgment.

Purchasers are solely responsible for the choice, selection, and use of ST products and ST assumes no liability for application assistance or the design of purchasers’ products.

No license, express or implied, to any intellectual property right is granted by ST herein.

Resale of ST products with provisions different from the information set forth herein shall void any warranty granted by ST for such product.

ST and the ST logo are trademarks of ST. For additional information about ST trademarks, refer to www.st.com/trademarks. All other product or service names are the property of their respective owners.

Information in this document supersedes and replaces information previously supplied in any prior versions of this document.

© 2023 STMicroelectronics – All rights reserved