

THIS DOCUMENT IS FOR REFERENCE ONLY. USERS MUST ASSURE THEY ARE USING THE CORRECT REVISION.

REVISIONS				
REV SYM	ECO NUMBER	DESCRIPTION	BY DATE	APP'D DATE
1		ORIGINAL RELEASE	K. KOONS 9.1.11	
2		REVISED PICTORIALLY	K. KOONS 11.11.11	

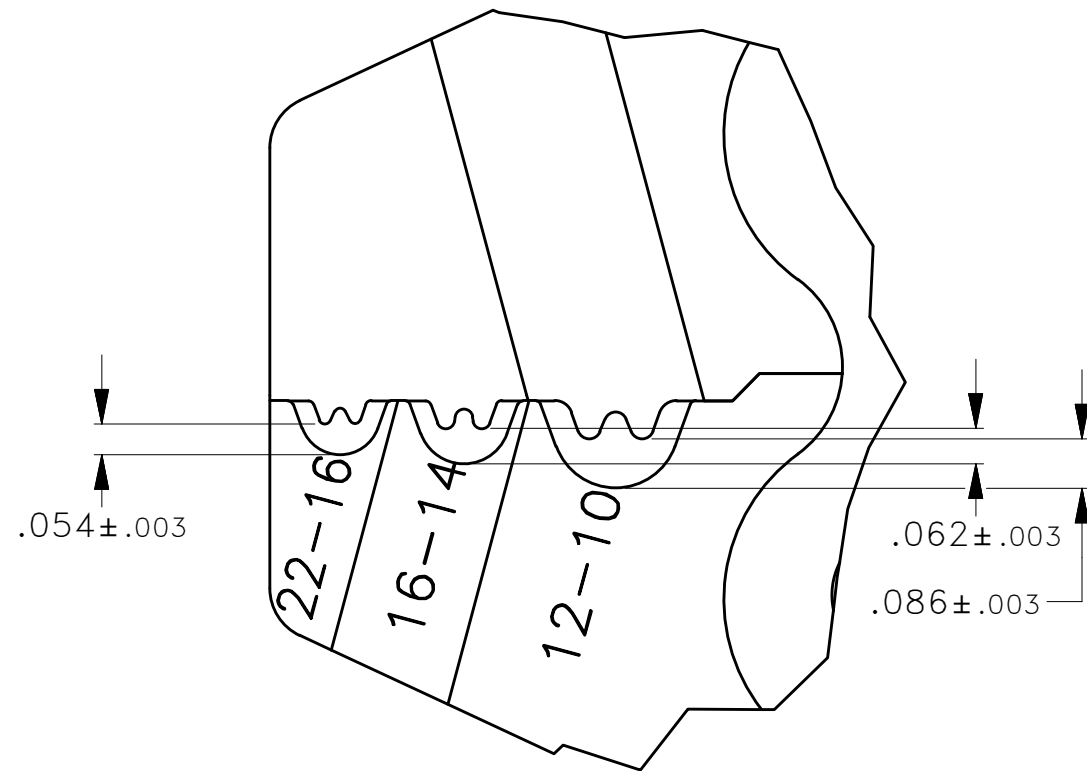

DETAIL A
GAGING DIMENSIONS

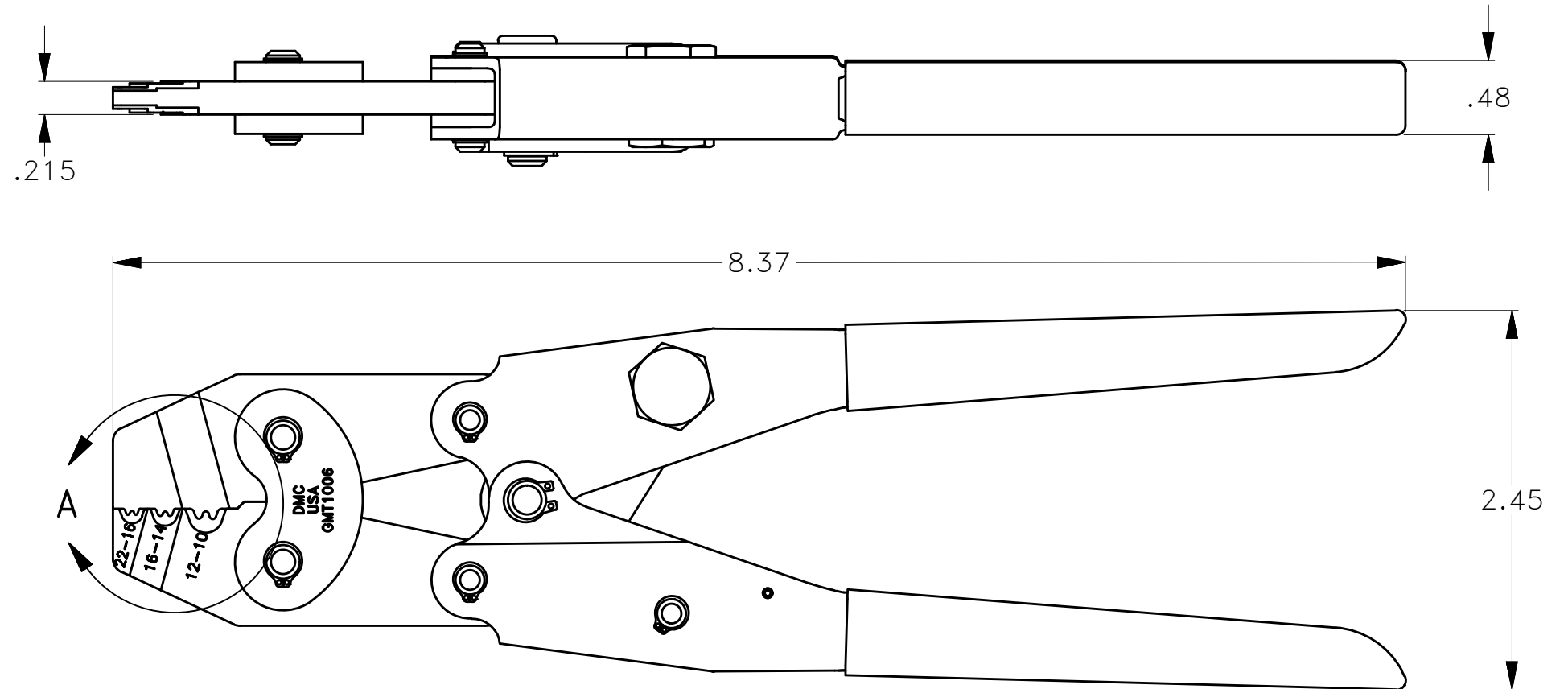

GAGING DIMENSIONS			
CAVITY	GO DIM	NO-GO DIM	GAGE
22-16	.051	.057	G327
16-14	.059	.065	G328
12-10	.083	.089	G329

UNCONTROLLED DOCUMENT
WILL NOT BE UPDATED

DIMENSIONS IN INCHES - UNLESS OTHERWISE SPECIFIED

1. FUNCTIONAL EQUIVALENT TO AMP TYCO 46447.

NOTES:

<p>RESTRICTED & CONFIDENTIAL</p> <p>CONFIDENTIAL PROPERTY OF DANIELS MANUFACTURING CORP. NOT TO BE DISCLOSED TO OTHERS, REPRODUCED OR USED FOR ANY OTHER PURPOSE EXCEPT AS AUTHORIZED IN WRITING BY DANIELS MANUFACTURING. MUST BE RETURNED TO DANIELS MANUFACTURING CORP. ON COMPLETION OF ORDER OR OTHER PURPOSE FOR WHICH LENT.</p> <p>CREATED FROM AN INVENTOR MODEL. CHANGES MUST BE REFLECTED IN THE 3D PART</p> <p>DO NOT SCALE DRAWING</p>	MATERIAL	ITEM	PART NO.	QTY.	DESCRIPTION/REMARKS
	HEAT TREAT	DRN. Kirk C Koons	DATE 9.1.11		 DANIELS MANUFACTURING CORP. ORLANDO, FLORIDA CAGE 11851
	FINISH	CHK'D.	DATE		
		APP'D.	DATE		
		NOTE: THIS DRAWING IS AN OUTLINE DRAWING OF THE RESPECTIVE DMC PART NUMBER INDICATED. ACTUAL DMC PART NUMBER IS DRAWING NUMBER WITHOUT THE "-ENV" SUFFIX			WHERE USED: SIZE B SCALE NTS CAD P/N GMT1006-ENV SHEET OF 1 1 POSTING DWG. NO. GMT1006-ENV REV. 2