

GMTE232C

BATTERY POWERED CRIMP TOOL

DMC DANIELS
MANUFACTURING
CORPORATION

DATASHEET

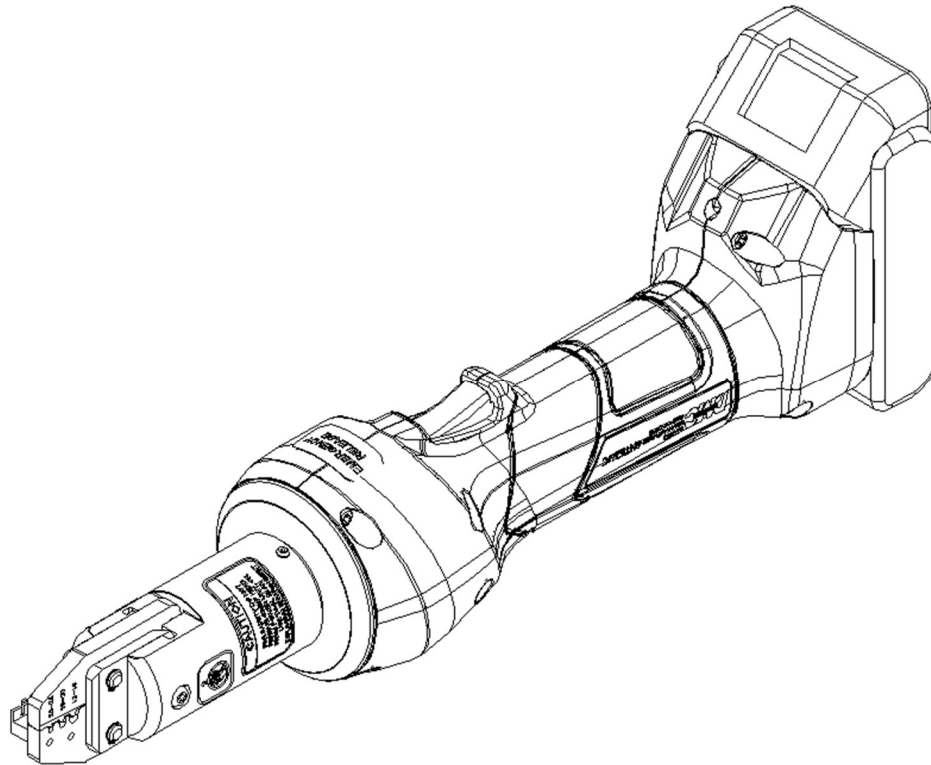

Description

The GMTE232C Battery Powered Crimp Tool is a hand held, self-contained crimp tool equivalent to the DMC GMT232 (M22520/37-01) hand crimp tool.

Safety

Safety is essential in the use and maintenance of DMC tools and equipment. This manual and any markings on the tool provide information for avoiding hazards and unsafe practices related to the use of this tool. Observe all of the safety information provided.

Purpose of this Manual

This manual is intended to familiarize all personnel with the safe operation and maintenance procedures for the following DMC tool:

GMTE232C Battery Powered Crimp Tool

Keep this manual available to all personnel. Replacement manuals are available upon request at no charge.

All specifications are nominal and may change as design improvements occur. DMC shall not be liable for damages resulting from misapplication or misuse of its products.

KEEP THIS MANUAL

GMTE232C BATTERY POWERED CRIMP TOOL

DATASHEET

Important Safety Information

| | |
|--|--|
| | ⚠ WARNING |
| | <p>Read and understand all of the instructions and safety information in this manual before operating or servicing this tool.</p> <p>Failure to observe this warning can result in severe injury or death.</p> |

| | |
|--|---|
| | ⚠ WARNING |
| | <p>Electric shock hazard:</p> <p>This tool is not insulated. When using this unit near energized electrical lines, use proper personal protective equipment.</p> <p>Failure to observe this warning can result in severe injury or death.</p> |

| | |
|--|---|
| | ⚠ WARNING |
| | <p>Wear eye protection when operating or servicing this tool.</p> <p>Failure to wear eye protection can result in serious eye injury from flying debris or hydraulic oil.</p> |

Important Safety Information

| | |
|--|--|
| | ⚠ WARNING |
| | <p>Skin injection hazard:</p> <p>Do not use hands to check for oil leaks. High pressure oil easily punctures skin causing serious injury, gangrene, or death. If injured, seek medical help immediately to remove oil.</p> |

| | |
|--|---|
| | ⚠ WARNING |
| | <p>Do not use solvents or flammable liquids to clean the crimping tool. Solvents or flammable liquids could ignite and cause serious injury or property damage.</p> |

| |
|--|
| ⚠ WARNING |
| <p>An incomplete crimp can cause a fire.</p> <ul style="list-style-type: none"> Use proper die, connector, and cable combinations. Improper combinations can result in an incomplete crimp. The relief valve will sound to indicate a completed crimp. If you do not hear the sound of the relief valve, the crimp is not complete. <p>Failure to observe these warnings can result in severe injury or death.</p> |

| | |
|--|---|
| | ⚠ WARNING |
| | <p>Keep hands away from the crimping head when crimping.</p> <p>Failure to observe this warning can result in severe injury or death.</p> |

| |
|--|
| ⚠ WARNING |
| <p>Do not dispose of batteries in a fire. They will vent fumes and may explode.</p> <p>Failure to observe this warning can result in severe injury from harmful fumes or burns from flying debris.</p> |

| |
|--|
| ⚠ WARNING |
| <p>Inspect tool and dies before use. Replace any worn or damaged parts. A damaged or improperly assembled tool can break and strike nearby personnel.</p> <p>Failure to observe this warning can result in severe injury or death.</p> |

| |
|---|
| ⚠ CAUTION |
| <ul style="list-style-type: none"> Do not operate the tool without dies. Damage to the ram or crimping head can result. Do not operate with the crimping head open. Damage to the ram or seals can result. This tool is not designed for continuous use. After 100 crimping cycles, allow the crimping tool to cool for 15 minutes. Do not place the tool in a vise. The crimping tool is designed for hand-held operation. Protect the crimping tool from rain and moisture. Water will damage the crimping tool and battery. Use this tool for the manufacturer's intended purpose only. <p>Failure to observe these precautions can result in injury or property damage.</p> |

GMTE232C BATTERY POWERED CRIMP TOOL

DATASHEET

DO NOT REMOVE TOOL HEAD

Identification

**DO NOT OPERATE TOOL
WITHOUT HEAD INSTALLED**

Important Safety Information

| ⚠ CAUTION |
|---|
| Do not allow anything to contact the battery terminals. |
| <ul style="list-style-type: none">Do not immerse the batteries in liquid. Liquid may create a short circuit and damage the battery. If batteries are immersed, contact your service center for proper handling.Do not place the battery into a pocket, tool pouch, or tool box with conductive objects. Conductive objects may create a short circuit and damage the battery.Do not place a battery on moist ground or grass. Moisture may create a short circuit and damage the battery. |
| Failure to observe these precautions can result in injury or property damage. |

| ⚠ CAUTION |
|--|
| <ul style="list-style-type: none">Do not store the battery at more than 60 °C (140 °F). Damage to the battery can result.Do not use another manufacturer's charger. Other manufacturers' chargers may overcharge and damage the battery.Do not attempt to open the battery. It contains no user-serviceable parts. |
| Failure to observe these precautions can result in injury or property damage. |

| ⚠ CAUTION |
|--|
| Do not perform any service or maintenance other than as described in this manual. Injury or damage to the tool may result. |
| Failure to observe this precaution can result in injury and property damage. |

Note: Keep all decals clean and legible, and replace when necessary.

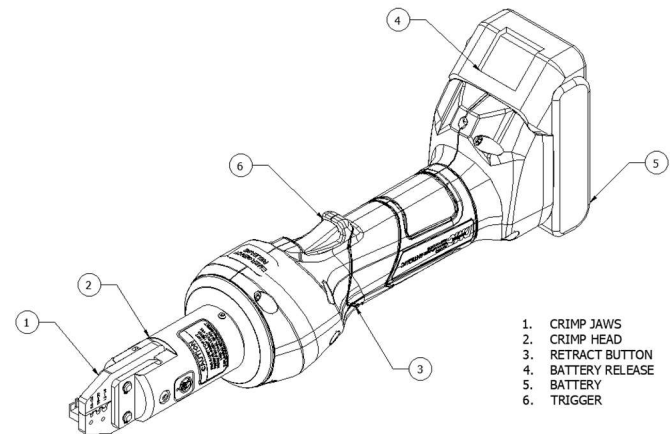

Specifications

Crimp Tool

Length=15" (381mm)
Width=2.9" (74mm)
Depth=4.5" (114mm)
Mass/Weight (with battery)=3.95lb (1.79kg)
Sound Level=75db (A) at 1 meter
Vibration=<2.5m/s²
Hydraulic Oil=Shell Tellus® T-15

Crimp Capacities

Max Crimp Force=1.5 tons (13kN)
Avg. Crimp Time=2 seconds
Avg. Crimps per Charge=Approx. 150

Battery

Charging Voltage=18VDC
Charging Time=22 minutes

US Pat. No. 7,254,982

GMTE232C

BATTERY POWERED CRIMP TOOL

DATASHEET

Operation

LED Work Light (White)

This LED automatically turns on when the trigger is pulled. It remains on for 10 seconds after the trigger is released.

LED Indicator (Red)

This tool is equipped with a special circuit board incorporating several important features to inform the user about the current status of the unit. The Red LED on the side of the tool signals in the following cases:

| What Happens... | Signal | What it Means... |
|--|--------|---|
| Flashing for 2 seconds | •• | Battery is inserted in tool |
| Constant light for 20 seconds at end of cycle | — | Battery charge is below 17V at beginning of cycle |
| Tool will not start, and constant light for 20 seconds when trigger is released | — | Battery charge is below 16V at beginning of cycle |
| Tool will stop, and constant light for 20 seconds after trigger is released | — | Battery voltage drops below 13V during cycle |
| Tool will stop, and flashing light for 20 seconds when trigger is released | •••• | Motor current exceeds 20A during cycle |
| | | Circuit has become too hot |

Pressure Sensor

This tool is equipped with a pressure sensor that alerts the user of an incomplete crimp.

- If the tool is manually retracted before completion of a crimp, the red LED and audible beep will be active for 2 seconds.
- If the tool is unable to reach the required crimp force, the red LED, work light, and an audible beep will pulse until after the trigger is released.

Preparing Cable

Follow the lug/connector manufacturer's instructions for appropriate cable strip length, and contact/wire assembly.

Crimping Cable

1. Insert the properly assembled connector into the crimp jaws.
2. Pull the trigger to make the crimp.

3. Hold the trigger down until crimping tool achieves pressure relief, which is accompanied by an audible "pop".
4. The crimp tool push rod retracts automatically.

CAUTION! DO NOT OPERATE TOOL WITHOUT DIE SET IN PLACE

*Note: If it is necessary to retract the tool push rod before a crimp cycle is completed, push and hold the **Emergency Release** button. Pushing and holding the **Emergency Release** button will result in the complete retraction of the push rod.*

Maintenance

Each Operating Day

Before Use:

1. Inspect jaws for wear or damage such as cracks, gouges, or chips.
2. Inspect the tool for damage or leaks. If damage is detected, return the tool to the DMC repair center for inspection.

After Use:

1. Wipe all tool surfaces clean with a damp cloth and mild detergent.
2. Charge the battery.
3. Fully retract the tool push rod.
4. Place the tool in the carrying case.
5. Store in a cool dry place.

Monthly

1. Thoroughly clean all surfaces.
2. Oil the push rod outer surface.

Annually or after 10,000 Crimps

1. Return the tool to the DMC repair center for inspection & calibration.

Trouble Shooting

Before You Begin

1. Make sure that the battery is charged. Recheck the battery after several minutes to make sure the battery is holding its charge.

GMTE232C

BATTERY POWERED CRIMP TOOL

DATASHEET

- Use a nonflammable contact cleaner or pencil eraser to clean the electrical contacts on the battery and crimp tool.
- Reinstall the battery and check the tool again.

Check Tool with Gage G411 (M22520/39-01)

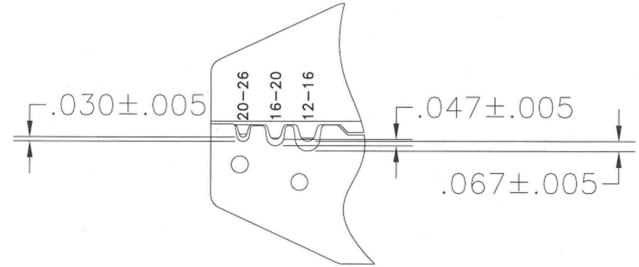

| Problem | Probable Cause | Probable Remedy |
|-----------------------------|---|---|
| Tool is inoperative | Dirt, contaminants, etc, in ram area of tool. | Clean tool. |
| | Crimping tool battery contacts damaged. | Reform contacts. |
| | Tool components worn or damaged. | Return tool to DMC. |
| Jaws stop during operation. | Oil level is low. | Return tool to DMC. |
| | Air in hydraulic system. | Pull trigger and hold emergency release button simultaneously. Hold for approximately 10 seconds. |
| Tool loses oil. | Damaged internal seal. | Return tool to DMC. |

BATTERY CHARGER OPERATING INSTRUCTIONS

Operating Environment

The charger is designed for use in dry areas. All ventilation slots must be kept free of debris. Keep away from heat sources, and if possible, out of direct sunlight. As ambient temperatures in excess of 95°F (35°C) may increase charging times significantly.

AC Connection

Before connecting the charger, check that the AC supply voltage is the same as what is indicated on the charger.

Specifications

Frequency = 50Hz – 60Hz
 Output Voltage = 7.2 – 18VDC
 Weight = 2.2lb (1.0kg)

Safety Instructions

The charger is designed only for Li-ion and Ni-MH batteries with voltages ranging from 9.6-18VDC, and capacities from 1.7 – 3.0Ah.

- Before you use the charger, check the power cord, and connectors for any signs of damage or aging.
- DO NOT open up the batteries, or the charger.
- DO NOT puncture, or expose to heat as there is RISK OF EXPLOSION.
- Only store in dry areas. Protect from moisture and dampness.
- Do not use if charger is defective, and never insert defective batteries.
- Observe the symbols on the charger’s nameplate.
- DO NOT throw old batteries into a fire, or dispose of as domestic waste.

Gaging the crimp tool

The crimp should be gaged periodically to ensure that proper crimping is being performed. Intervals between checks should be determined by the customer based on tool use and environment the tool is used in.

CAUTION: DO NOT CRIMP GAGE!

“GO” Gaging

With the crimp jaws in the fully closed position, insert the **GREEN “GO”** gage end into the appropriate cavity. The gage must pass freely through the crimp cavity.

“NO-GO” Gaging

With the crimp jaws in the fully closed position, attempt to insert the **RED “NO-GO”** gage end into the appropriate cavity. The gage may partially enter, but must not pass completely through the cavity.

GMTE232C

BATTERY POWERED CRIMP TOOL

DATASHEET

- Keep metal objects that could cause shorts away from the charger.
- DO NOT dismantle the charger, or batteries.

Battery Charger Operation

Green L.E.D. – If the charger is connected to AC line, the green L.E.D. will flash repeatedly until a battery is installed for charging.

Charging a Battery – When battery is inserted on to the charger, the red L.E.D. will illuminate, and stay on while charging occurs. The green L.E.D will turn off while the battery is less than 80% charged. Both green and red L.E.D.'s will illuminate when the battery is greater than 80% charged, but not fully charged. When charging is complete, the red L.E.D. will turn off, and the green L.E.D. will stay on. If you leave the battery on the charger after it is charged, the charger will switch to its trickle charge mode for 24 hours.

Yellow L.E.D. – Flashing indicates trouble with the cooling system. Ensure that all cooling vents, and the battery connections are free of dust, or debris. If flashing continues, return the unit to DMC for repair. Continuous illumination indicates that a conditioning charge is occurring. This happens when the battery being charged is at either a very low, or very high temperature. This can also occur if you attempt to charge a fully charged battery. These conditions will increase charging times.

Other Possible Conditions Displayed – Flashing red with green off indicates the charger is overheated. Unplug the charger and allow it to cool down. Flashing red with flashing green indicates a defective battery.

Spare Battery Parts

| | |
|-------------------------|-------------|
| 120 VAC Battery Charger | HDE-LI-120C |
| 230 VAC Battery Charger | HDE-LI-230C |
| 18V Replacement Battery | HDE-LI-B |
| 120 VAC Power Adapter | HDE-120AC-A |
| 230 VAC Power Adapter | HDE-230AC-A |

DMC offers complete refurbishing and recalibration services.

DMC specially engineers and manufactures complete tool kits to satisfy individual customer requirements, such as total aircraft support general shop maintenance or production, on board ship and vehicle service, etc.

BLUETOOTH CONNECTIVITY

This tool features Bluetooth connectivity for tool monitoring via Klauke i-press® software or the Klauke i-press app.

I-press® software features include:

- Exporting all tool data to check the tool status.
- Providing with proof of quality in the form of a project record.
- Free downloading

I-press® app:

- Made easy - Your Next Generation tool connects to the i-press® app via Bluetooth - you can now use the comprehensive range of functions.
- Everything under control - You can, for example, display the last service date, the last five pressure values, the device temperature or the number of crimps you can still make with the connected tool.
- Record, verify and archive - Once the project is complete, you will receive an overview containing all information and pressure values as an attachment. Very clearly arranged and revamped as a PDF for printing and submitting.

The software can be downloaded at:

<https://www.klauke.com/de/en/ipress-connectivity-software>



GMTE232C

BATTERY POWERED CRIMP TOOL

DATASHEET

TOOL INFORMATIONAL DISPLAY

When a battery is installed onto the tool, the following information can be accessed.

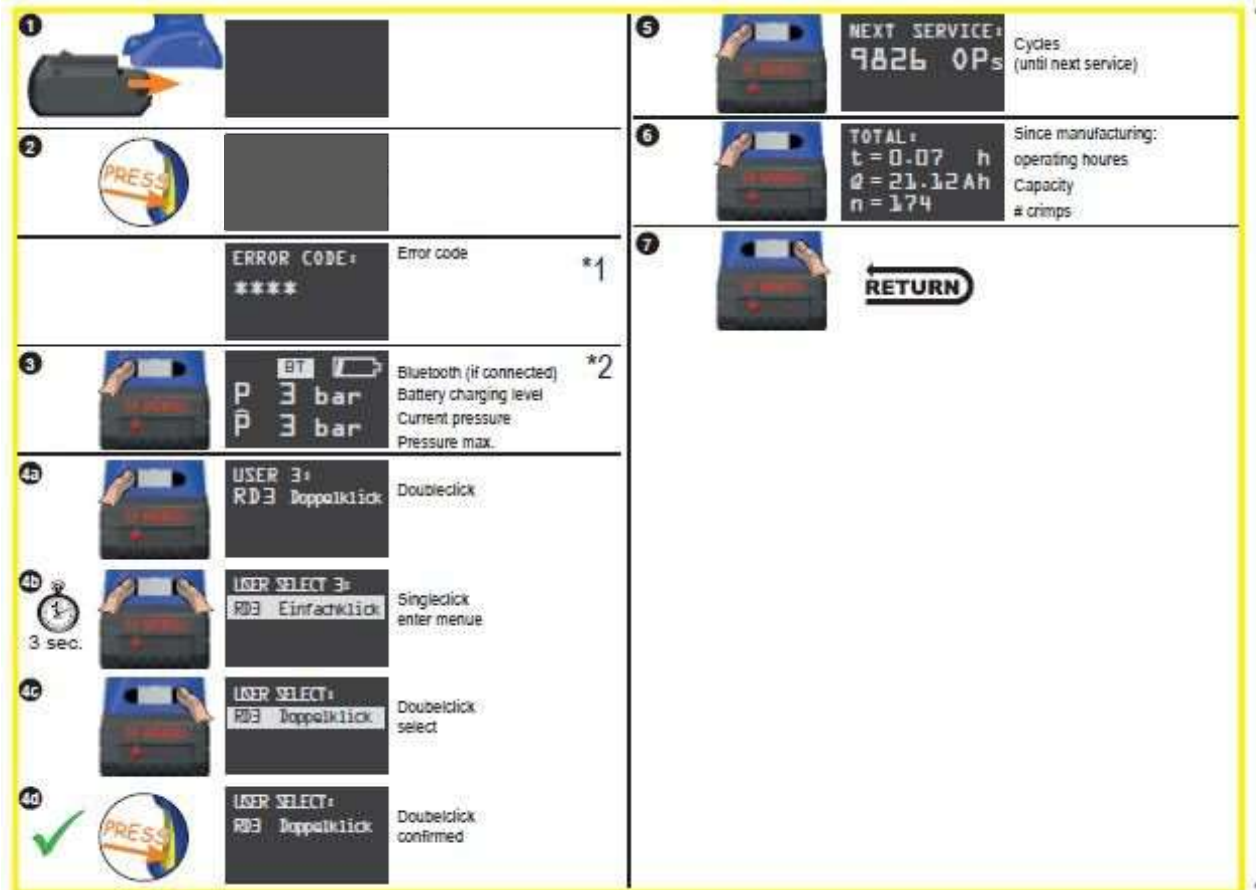

Install a charged battery onto the tool.

1. Press the tool trigger to activate the display. Any applicable error codes will be display. The 17 possible error codes are listed below. If an error code is displayed, the tool's red LED will also flash.
2. The first screen will display whether tool is connected via Bluetooth, the battery charge level, current pressure & max pressure.
3. Pressing the left button once will display the firmware version, and tool serial number.
 - a. Pressing the left button again displays the current user.
 - b. Pressing and holding both button lets you
 - c. select a current user.
 - d. Use the right button to select the desired user.
 - e. Press the tool trigger to confirm selection and return.
4. Pressing the left button once again will display the number of cycles and days until the next service interval.
5. Pressing the left button once again will display the total operating hours, total Amp Hours (Ah) and the total number cycles.
6. Press the right button will allow you to go back to the previous screen.

GMTE232C

BATTERY POWERED CRIMP TOOL



DATASHEET

Error Codes

1. Overcurrent Fuse
2. Overcurrent Comparator
3. Overheat Board
4. Overheat Battery
5. Battery Empty, Operation Stop
6. Faulty Crimp with Motor in Operation
7. Faulty Crimp without Motor in Operation
8. Low Battery
9. Battery Empty
10. Battery Low
11. Tool Deactivated
12. Service Necessary
13. RTC not Found
14. BT Unit not Found
15. Pressure Sensor not Found
16. Burst Pressure Exceeded
17. Battery Temperature Too Low

neglect or accident. This warranty is in lieu of all other warranties express or implied. No warranty, express or implied, is made or authorized to be made or assumed with respect to products of Daniels Manufacturing Corporation other than those herein set forth.

Limitation of Liability

DANIELS MANUFACTURING CORPORATION IS NOT LIABLE FOR CONSEQUENTIAL OR SPECIAL DAMAGES OF ANY NATURE OR KIND RESULTING FROM THE USE, OR MISUSE, OF ANY OF ITS PRODUCTS. OWNERS AND USERS OF DMC PRODUCTS ASSUME FULL RESPONSIBILITY FOR INSTRUCTING THEIR EMPLOYEES IN THE PROPER AND SAFE USE OF SUCH PRODUCTS.

Limited Warranty

DMC (Daniels Manufacturing Corporation) warrants each new product sold by it to be free from defects in material and workmanship under normal use and service. DMC's obligation under this warranty is limited to the free correction or, at DMC's option, the refund of the purchase price of any such product which proves defective in normal service within ninety (90) days after delivery to the first user, provided that the product is returned to DMC with all transportation charges prepaid and which shall appear to DMC's satisfaction, after DMC's inspection, to have been defective in material and workmanship, it being understood that DMC products are not consumer products. This warranty shall not cover any damage to any product which, in the opinion of DMC, was caused by normal wear, misuse, improper operation, tampering,