



Preset Click Type Torque Wrench With 5/16 Bit For SMA, 2.92mm, 3.5mm Connectors Preset to 8 in-lbs

Torque Wrenches Technical Data Sheet

PE5011-1

Features

- Designed for continual use
- Will "click" once preset torque value is achieved
- Designed to avoid over torque

Applications

- Attaching test cables in lab environments
- Final production attachment
- Field install and testing applications
- Applying accurate torque
- Avoiding over torque

Description

PE5011-1 click type torque wrench, designed for 1.85mm, 2.4mm, 2.92mm, 3.5mm and SMA connectors, has a 5/16 bit with a preset value of 8 in-lbs. Pasternack's PE5011-XX click type torque wrenches allow accurate mating force when assembling and disassembling a variety of RF coaxial connectors. The unique feature of click type RF wrenches is that once the preset torque value is reached, they will "click" which can be heard and felt, followed by a slight bend at the head, alerting to the user to stop applying torque on the connector. Pasternack's click type 1.85mm, 2.4mm, 2.92mm, 3.5mm and SMA torque wrenches are in-stock and also available for a wide variety of other RF connectors, all of which ship the same day. These torque wrenches are calibrated at time of manufacture in compliance with ANSI/NCSL Z540 or other internationally recognized standard.

Configuration

| | |
|----------------------------|-------------------|
| Torque Type | Preset |
| Design Type | Click Type |
| Hex Size | 5/16 inch |
| Torque Setting | 8 in-lbs [0.9 Nm] |
| Torque Accuracy Percentage | ±4 % |

Size

| | |
|-----------------|--------------------|
| Length | 6.8 in [172.72 mm] |
| Handle Diameter | 0.63 in [16 mm] |

| | |
|--------------|----------------------|
| Weight | 0.348 lbs [157.85 g] |
| Handle Color | Blue |

Compliance Certifications (see [product page](#) for current document)

Notes:

- Do not use on damaged connectors.
- The torque wrench is verified at the factory and cannot be calibrated by the user. We cannot re-calibrate the unit.
- To improve performance of wrench that hasn't been used recently, actuate the wrench by clicking the wrench head back and forth several times before use. This will spread the lubricant through the internal mechanism.
- Click type tools required smooth, consistent clicking action. Each torquing action should be completed within 2 seconds.
- Slower or faster torquing action will detract from accuracy.

Click the following link (or enter part number in "SEARCH" on website) to obtain additional part information including price, inventory and certifications: [Preset Click Type Torque Wrench With 5/16 Bit For SMA, 2.92mm, 3.5mm Connectors Preset to 8 in-lbs PE5011-1](#)



Preset Click Type Torque Wrench With 5/16 Bit For SMA, 2.92mm, 3.5mm Connectors Preset to 8 in-lbs

Torque Wrenches Technical Data Sheet

PE5011-1

Preset Click Type Torque Wrench With 5/16 Bit For SMA, 2.92mm, 3.5mm Connectors Preset to 8 in-lbs from Pasternack Enterprises has same day shipment for domestic and International orders. Our RF, microwave and millimeter wave products maintain a 99.4% availability and are part of the broadest selection in the industry.

Click the following link (or enter part number in "SEARCH" on website) to obtain additional part information including price, inventory and certifications: [Preset Click Type Torque Wrench With 5/16 Bit For SMA, 2.92mm, 3.5mm Connectors Preset to 8 in-lbs PE5011-1](https://www.pasternack.com/preset-torque-wrench-5-16-bit-sma-2.92mm-3.5mm-8in-lbs-pe5011-1-p.aspx)

URL: <https://www.pasternack.com/preset-torque-wrench-5-16-bit-sma-2.92mm-3.5mm-8in-lbs-pe5011-1-p.aspx>

The information contained in this document is accurate to the best of our knowledge and representative of the part described herein. It may be necessary to make modifications to the part and/or the documentation of the part, in order to implement improvements. Pasternack reserves the right to make such changes as required. Unless otherwise stated, all specifications are nominal. Pasternack does not make any representation or warranty regarding the suitability of the part described herein for any particular purpose, and Pasternack does not assume any liability arising out of the use of any part or documentation.

PE5011-1 CAD Drawing

Preset Click Type Torque Wrench With 5/16 Bit For SMA,
2.92mm, 3.5mm Connectors Preset to 8 in-lbs

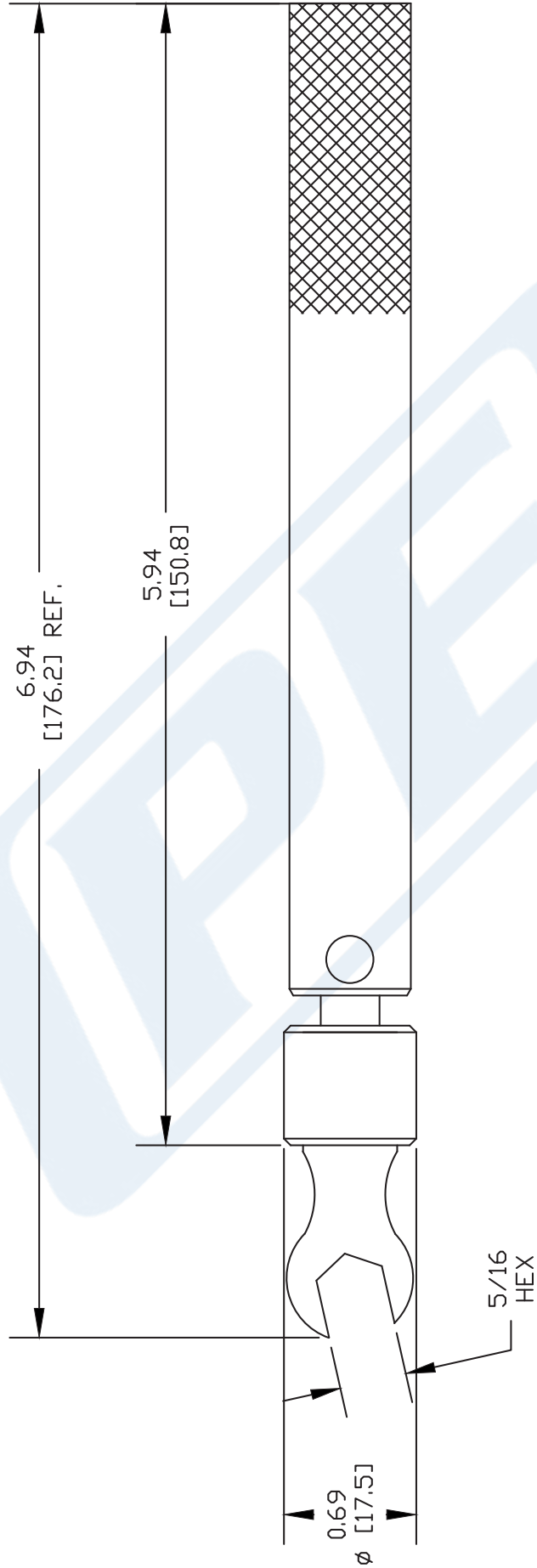

NOTES:
 1. UNLESS OTHERWISE SPECIFIED ALL DIMENSIONS ARE NOMINAL.
 2. ALL SPECIFICATIONS ARE SUBJECT TO CHANGE WITHOUT NOTICE AT ANY TIME.
 3. DIMENSIONS ARE IN INCHES [mm].
 4. FITS MIL-C-17 AND EQUIVALENT CABLES.

DWG TITLE
PE5011-1

FSCM NO. 53919

CAD FILE 012813 SCALE N/A SIZE A 2231

PE PASTERNAK®
 Pasternack Enterprises, Inc.
 P.O. Box 16759 | Irvine | CA | 92623
 Phone: (949) 261-1920 | Fax: (949) 261-7451
 Website: www.pasternack.com | E-Mail: sales@pasternack.com