

**STRAIGHT PLUG CLAMP TYPE**  
**CABLE 2.6/50 8**

**R125.091.001**  
**SERIES SMA**

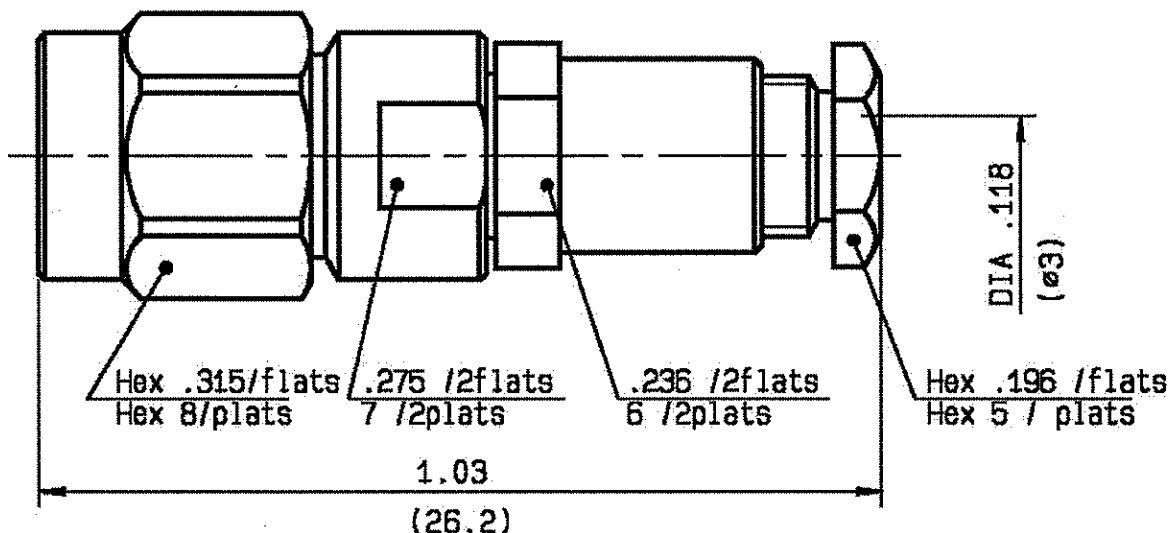

NOMINAL IMPEDANCE	50 $\Omega$	CABLES : KX 22A
FREQUENCY RANGE	0-12.4 GHz	FB 188
TEMPERATURE RATING	-65/+165 °C	FB 318
V.S.W.R	1.15 + .02 x F(GHz)Max1	
RF INSERTION LOSS	0.06 $\sqrt{F}$ (GHz) dB Max1	
VOLTAGE RATING	250 Veff Max1	
DIELECTRIC WITHSTANDING VOLTAGE	750 Veff Min1	
INSULATION RESISTANCE	5000 M $\Omega$ Min1	OTHERS CHARACTERISTICS
HERMETIC SEAL	NA Atm.cm <sup>3</sup> /s	CABLE RETENTION
LEAKAGE (pressurized only)	NA	CENTER CONTACT RETENTION
MECHANICAL DURABILITY	500 Cycles	Axial force - mating end
WEIGHT	0 gr	Axial force - opposite end
SPECIFICATION		Torque
		RECOMMENDED TORQUES
		Mating
		Panel nut
		Clamp nut
		90 N Min1
		27 N Min1
		27 N Min1
		NA cm.N Min1
		100 cm.N
		NA cm.N
		100 cm.N

CONNECTOR PARTS:	MATERIALS	FINISH	(all values are given in micrometers)
BODY	STAINLESS STEEL	PASSIVATED .	
OUTER CONTACT			
CENTER CONTACT	BRASS	GOLD 1.3 OVER NICKEL 2	
INSULATOR	PTFE	-	
GASKET	SILICONE RUBBER	-	
OTHERS PIECES	BRASS	NICKEL 2	

ISSUE	CREATION DATE	FILE PART-NUMBER
0826 C00	17/04/1989	-



The information given here is subject to change without notice.  
Design changes may be in order to improve the product .

Connect to the future

SULLOMIN

STRAIGHT PLUG , CLAMP VERSION FOR  
2.6/50 CABLE

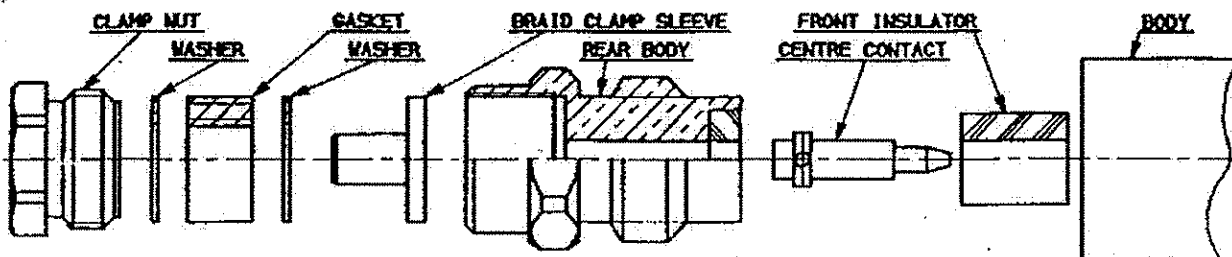

①

- 1-1 Slide the clamp nut, the 1st washer, the gasket and the 2nd washer onto the cable .
- 1-2 Strip the cable .
- 1-3 Cut the jacket ( 2 slots ) .

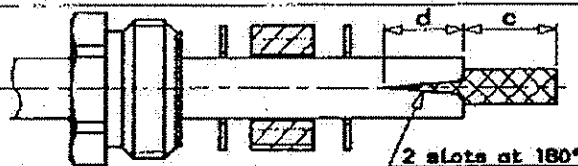

Stripping	a	b	c	d	e
Inch	-	-	.196	.177	.044
mm	-	-	5	4.5	0.3

②

- 2-1 Slide clamp braid sleeve over braid .
- 2-2 Cut the braid flush with the clamp braid sleeve .
- 2-3 Strip the dielectric as shown .

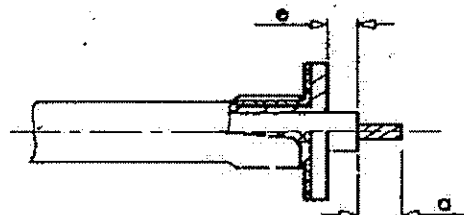

③

- 3-1 Screw sub-assembly into the connector rear body (coupling torque 3.54 in. lb)
- 3-2 Slide centre contact over centre conductor until it bottoms against insulator
- 3-3 Solder centre contact .
- 3-4 Mount front insulator .

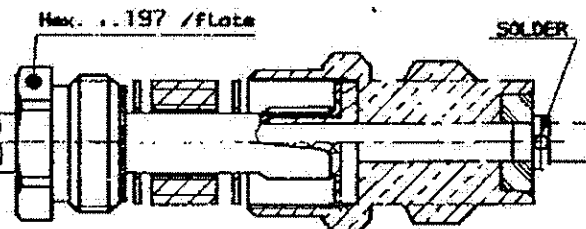

④

- 4-1 Screw sub-assembly into the connector body .
- Recommended coupling torque  
8.86 in. lb

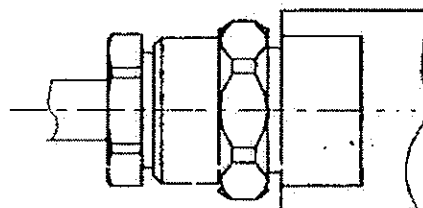

ISSUE	REVISION No	DESCRIPTION	BY	DATE

Initiated on

Superseded on

The information given here is subject to change without notice. Design changes may be made in order to improve the product.

