

**STRAIGHT SQUARE FLANGE JACK CLAMP TYPE**  
**CABLE 10 + 11/50**

**R185.260.000**  
**SERIES 7-16**

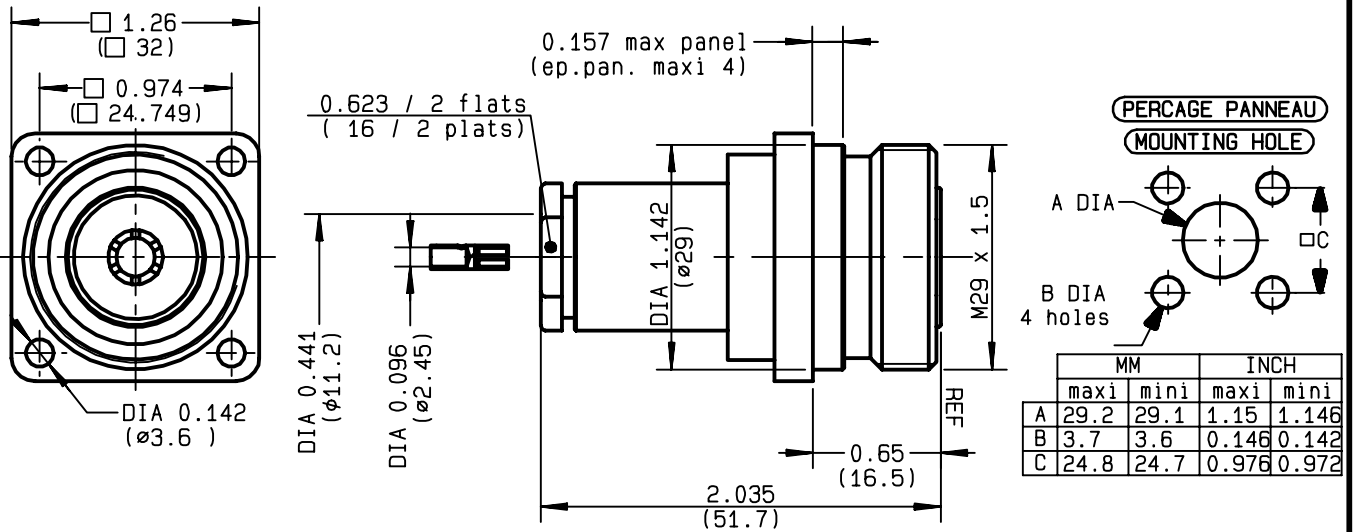

NOMINAL IMPEDANCE	<b>50</b>	$\Omega$
FREQUENCY RANGE	<b>0-7.5</b>	GHz
TEMPERATURE RATING	<b>-55/+155</b>	$^{\circ}\text{C}$
V.S.W.R	<b>1.20</b> +	x F(GHz)Maxi
RF INSERTION LOSS	<b>0.05</b>	$\sqrt{F}$ (GHz) dB Maxi
VOLTAGE RATING	<b>1400</b>	Veff Maxi
DIELECTRIC WITHSTANDING VOLTAGE	<b>2700</b>	Veff Mini
INSULATION RESISTANCE	<b>10000</b>	M $\Omega$ Mini
HERMETIC SEAL	<b>NA</b>	Atm.cm <sup>3</sup> /s
LEAKAGE (pressurized only)	<b>NA</b>	
MECHANICAL DURABILITY	<b>500</b>	Cycles
WEIGHT		gr
SPECIFICATION		

CABLES :	<b>KX 13</b>
	<b>KX 4</b>
	<b>RG 213</b>
	<b>RG 214</b>
	<b>RG 225</b>
	<b>RG 393</b>
OTHERS CHARACTERISTICS	
	<b>ROS : 1.10 a 3 GHz</b>
CABLE RETENTION	<b>250</b> N Mini
CENTER CONTACT RETENTION	
Axial force - mating end	<b>200</b> N Mini
Axial force - opposite end	<b>100</b> N Mini
Torque	<b>NA</b> cm.N Mini
RECOMMENDED TORQUES	
Mating	<b>NA</b> cm.N
Panel nut	<b>NA</b> cm.N
Clamp nut	<b>800</b> cm.N

CONNECTOR PARTS	MATERIALS	FINISH	(all values are given in micrometers)
BODY	BRASS	BBR 0.5 OVER SILVER 3	
OUTER CONTACT	BRASS	SILVER 5 OVER COPPER 0.5	
CENTER CONTACT	BERYLLIUM COPPER	SILVER 5 OVER COPPER 0.5	
INSULATOR	PTFE	-	
GASKET	-	-	
OTHERS PIECES	BRASS	BBR 2	

ISSUE	CREATION DATE	FILE PART-NUMBER
<b>9944D00</b>	<b>18/05/1994</b>	<b>EPC96-02</b>



GAUTIER

The information given here is subject to change without notice. Design changes may be in order to improve the product.

*Connect to the future*



**R185.260.000**

ISSUE 9944D00 SERIES 7-16

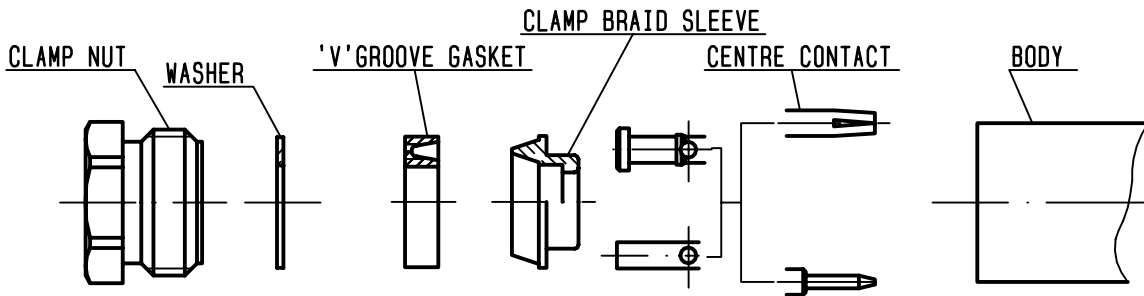

①

Strip the cable .

-  
-  
-  
-

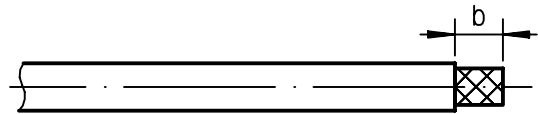

Stripping	a	b	c	d	e
inch	0.197	0.335	0	0	0.059
mm	5	8.5			1.5

②

Slide the clamp nut and the 'V' groove gasket onto the cable .  
Slide clamp braid sleeve over braid .  
Fold back braid and trim off surplus braid .  
Trim back dielectric as shown .

-

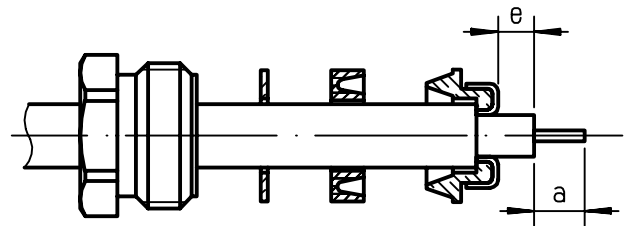

③

Solder the cable inner conductor into centre contact .

-  
-  
-  
-  
-  
-

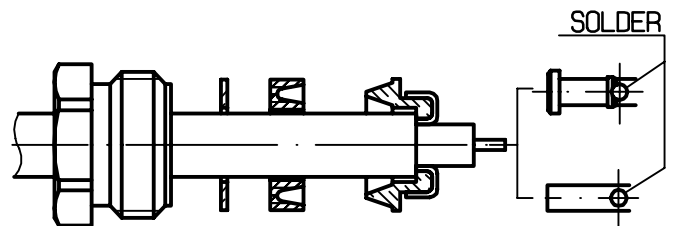

④

Screw sub-assembly into the connector body .  
( recommended coupling torque 70.87 in.lb )

-  
-

