

Coaxial Bi-Directional Coupler

ZFBDC20-13HP+

50Ω Up to 20W 40 to 1000 MHz

Maximum Ratings

Operating Temperature	-55°C to 100°C
Storage Temperature	-55°C to 100°C

Permanent damage may occur if any of these limits are exceeded.

Coaxial Connections

INPUT	1
OUTPUT	2
COUPLED (forward)	4
COUPLED (reverse)	3

Outline Drawing

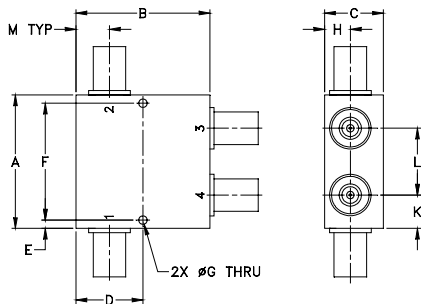

Outline Dimensions (inch/mm)

A	B	C	D	E	F	G
2.00	2.00	.88	1.000	0.13	1.750	0.125
50.80	50.80	22.35	25.40	3.30	44.45	3.18

H	J	K	L	M	wt
0.38	--	0.50	1.00	0.50	grams
9.65	--	12.70	25.40	12.70	250.0

Features

- excellent mainline loss, 0.4 dB typ.
- excellent directivity, 23 dB typ.
- high power, up to 20W
- rugged shielded case

Applications

- power leveling & monitoring
- GPS
- cellular/PCS



SMA version shown
CASE STYLE: JD1252

Connectors	Model
BNC	ZFBDC20-13HP+
SMA	ZFBDC20-13HP-S+

+RoHS Compliant

The +Suffix identifies RoHS Compliance. See our web site for RoHS Compliance methodologies and qualifications

Bi-Directional Coupler Electrical Specifications

FREQ. (MHz)	COUPLING (dB)		MAINLINE LOSS ¹ (dB)		DIRECTIVITY (dB)		VSWR (:1)	POWER ² INPUT (W)
	Nom.	Flatness	Typ.	Max.	Typ.	Min.		
f_L - f_U							Typ.	Max.
40-1000	20±0.5	±1.2	0.6	1.1	22	15	1.20	10
800-1000	20.5±0.7	±0.5	0.6	1.1	23	15	1.30	10
40-500	19.5±0.5	±0.5	0.3	0.7	25	15	1.10	20

¹ Mainline loss includes theoretical power loss at coupled port.

² Power rating is specified up to +55°C. Power Input Specifications at +100°C is 50% value at +55°C. For specifications limits between +55°C and +100°C, derate linearly.

Typical Performance Data

Frequency (MHz)	Mainline Loss (dB)		Coupling (dB)		Directivity (dB)		Return Loss (dB)		
	In-Out	In-Cpl Fwd	In-Cpl Rev	Out-Cpl Rev	Out-Cpl Fwd	In-Cpl Rev	In	Out	Cpl Fwd
40.00	0.11	19.45	19.63	18.97	19.34	20.48	20.24	18.42	18.26
100.00	0.13	19.37	19.43	25.87	23.24	36.29	36.23	33.44	33.87
200.00	0.22	19.44	19.61	30.40	23.15	32.98	32.87	31.98	31.96
300.00	0.27	19.57	19.77	33.08	23.36	26.91	26.08	25.78	25.27
400.00	0.32	19.71	19.96	37.14	23.79	23.58	22.88	22.34	21.82
500.00	0.37	19.86	20.14	46.58	24.59	21.33	20.59	20.10	19.44
600.00	0.42	20.00	20.32	38.80	25.89	19.73	18.94	18.52	17.77
800.00	0.53	20.34	20.68	26.00	31.65	17.74	16.92	16.61	15.68
920.00	0.61	20.61	20.89	21.83	36.88	17.18	16.15	16.16	14.86
1000.00	0.69	20.83	21.08	19.32	32.27	17.01	15.83	16.08	14.52

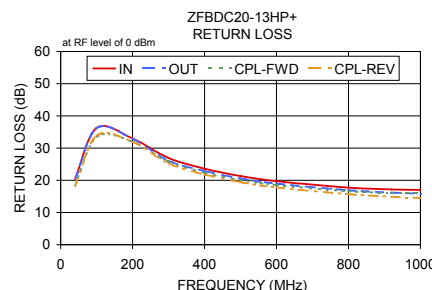
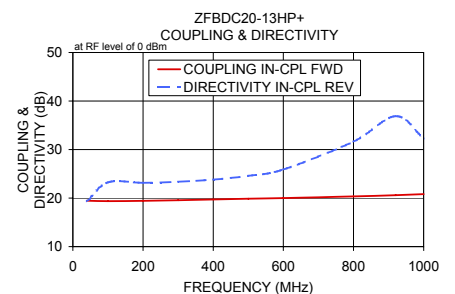
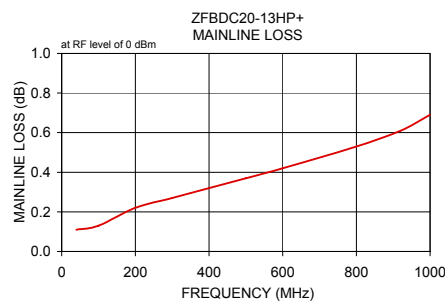

Electrical Schematic

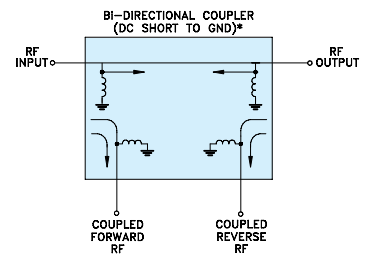

* ELECTRICAL SCHEMATIC IS FOR BI-DIRECTIONAL COUPLER WITH INTERNAL TRANSFORMER(S) THAT ROUTES DC FROM RF PORTS TO GROUND.

Notes

- Performance and quality attributes and conditions not expressly stated in this specification document are intended to be excluded and do not form a part of this specification document.
- Electrical specifications and performance data contained in this specification document are based on Mini-Circuit's applicable established test performance criteria and measurement instructions.
- The parts covered by this specification document are subject to Mini-Circuits standard limited warranty and terms and conditions (collectively, "Standard Terms"); Purchasers of this part are entitled to the rights and benefits contained therein. For a full statement of the Standard Terms and the exclusive rights and remedies thereunder, please visit Mini-Circuits' website at www.minicircuits.com/WCLStore/terms.jsp



www.minicircuits.com P.O. Box 350166, Brooklyn, NY 11235-0003 (718) 934-4500 sales@minicircuits.com

REV. D
M151107
ED-13224
ZFBDC20-13HP+
WP/CP/AM
151007
Page 1 of 1