

Coaxial Directional Coupler

50Ω

0.1 to 2000 MHz

ZFDC-20-5+



BNC version shown

CASE STYLE: K18

Connectors	Model
BNC	ZFDC-20-5+
SMA	ZFDC-20-5-S+
N-TYPE	ZFDC-20-5-N+
BRACKET (OPTION "B")	

+RoHS Compliant

The +Suffix identifies RoHS Compliance. See our web site for RoHS Compliance methodologies and qualifications

Maximum Ratings

Operating Temperature -55°C to 100°C

Storage Temperature -55°C to 100°C

Permanent damage may occur if any of these limits are exceeded.

Coaxial Connections

INPUT	3
OUTPUT	1
COUPLED	2

Features

- very wideband, 0.1 to 2000 MHz
- excellent directivity, 27 dB typ.
- excellent mainline loss, 0.7 dB typ.
- rugged shielded case

Applications

- cellular
- instrumentation
- communication receivers & transmitters

Outline Drawing

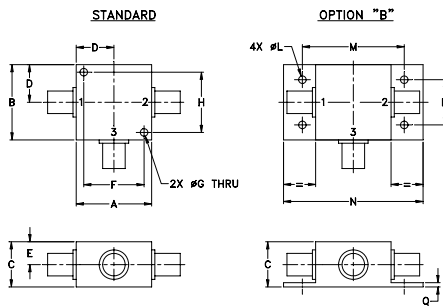

Outline Dimensions (inch/mm)

A	B	C	D	E	F	G	H
1.25	1.25	.75	.63	.38	1.00	.125	1.000
31.75	31.75	19.05	16.00	9.65	25.40	3.18	25.40
J	K	L	M	N	P	Q	wt
--	--	.125	1.688	2.18	.75	.07	grams
--	--	3.18	42.88	55.37	19.05	1.78	70.0

Electrical Specifications

FREQ. RANGE (MHz)	COUPLING* (dB)		MAINLINE LOSS ¹ (dB)				DIRECTIVITY (dB)			VSWR (:1)	POWER INPUT (W)						
	Nom.	Flatness	L		M		U				Typ.	L	MU				
			Typ.	Max.	Typ.	Max.	Typ.	Max.	Typ.					Min.	Typ.	Min.	
f _L -f _U	19.5±0.5	±0.5	0.3	1.0	0.7	1.4	1.5	2.3	30	20	27	20	22	10	1.2	0.5	2.0

L = low range [f_L to 10 f_L] M = mid range [10 f_L to f_U/2] U = upper range [f_U/2 to f_U]

1. Mainline loss includes theoretical power loss at coupled port.

* Above 1000 MHz, coupling flatness ±1 dB.

Typical Performance Data

Frequency (MHz)	Mainline Loss (dB) In-Out	Coupling (dB) In-Cpl	Directivity (dB)	Return Loss (dB)		Cpl
				In	Out	
0.10	0.71	19.79	25.09	11.79	11.84	12.78
0.50	0.49	19.57	33.79	21.84	22.89	21.74
0.90	0.44	19.52	34.79	23.69	25.23	23.40
188.00	0.36	19.46	32.56	26.83	27.83	26.54
544.00	0.69	19.85	30.03	22.02	22.00	23.17
920.00	1.07	20.18	28.13	19.60	20.58	18.75
1020.00	1.17	20.18	28.46	19.23	20.30	17.73
1136.00	1.28	20.13	29.48	18.96	20.07	16.64
1310.00	1.41	19.96	34.06	18.82	19.75	15.02
2000.00	1.91	19.34	18.40	18.91	17.73	10.05

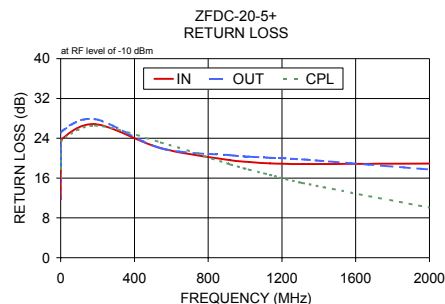
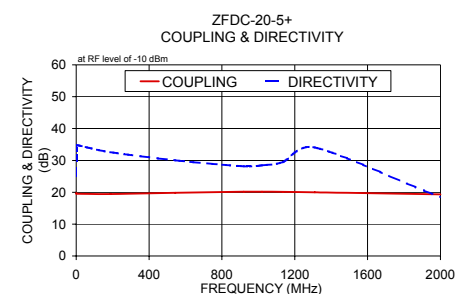
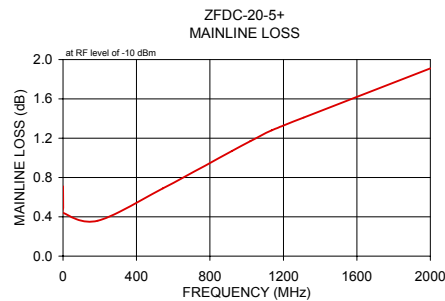

Electrical Schematic

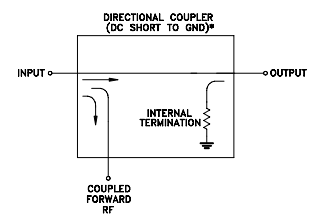

* ELECTRICAL SCHEMATIC IS FOR DIRECTIONAL COUPLER WITH INTERNAL TRANSFORMERS THAT ROUTES DC FROM RF PORTS TO GROUND.

Notes

- Performance and quality attributes and conditions not expressly stated in this specification document are intended to be excluded and do not form a part of this specification document.
- Electrical specifications and performance data contained in this specification document are based on Mini-Circuit's applicable established test performance criteria and measurement instructions.
- The parts covered by this specification document are subject to Mini-Circuits standard limited warranty and terms and conditions (collectively, "Standard Terms"); Purchasers of this part are entitled to the rights and benefits contained therein. For a full statement of the Standard Terms and the exclusive rights and remedies thereunder, please visit Mini-Circuits' website at www.minicircuits.com/WCLStore/terms.jsp

Mini-Circuits

www.minicircuits.com P.O. Box 350166, Brooklyn, NY 11235-0003 (718) 934-4500 sales@minicircuits.com

REV. C
M151107
ZFDC-20-5+
WZ/TD/CP/AM
151007