



COAXIAL SOLID-STATE

# High Power Amplifier

**ZHL6G018G020+**  
**ZHL6G018G020X+**

Mini-Circuits

50Ω 20W 6 to 18 GHz

## THE BIG DEAL

- High output power, 20W
- 6 to 18 GHz ultra broadband
- Suitable for modulated, CW, and pulsed signals
- High power gain, 40 dB typical
- No damage with VSWR of 3:1
- Protected against: reverse polarity, over voltage, high temperature

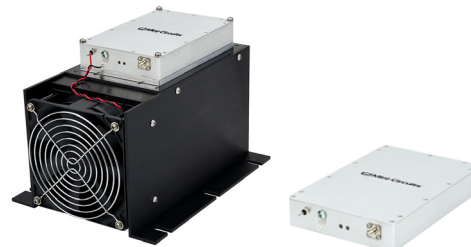

Generic photo used for illustration purposes only

## APPLICATIONS

- High Power test sets
- Burn-in systems
- 5G
- Wi-Fi
- Communications
- Radar

<b>Model No.</b>	ZHL6G018G020+	ZHL6G018G020X+
<b>Option</b>	With Heatsink & Fan	Without Heatsink & Fan
<b>Case Style</b>	BT3013	
<b>Connectors</b>	IN-SMA, OUT-SMA	

**+RoHS Compliant**  
The +Suffix identifies RoHS Compliance.  
See our website for methodologies and qualifications

## PRODUCT OVERVIEW

ZHL6G018G020X+ is a Class AB, high power amplifier providing 20W (typical) of saturated output power over the 6 to 18 GHz band, ideal for a variety of high power test setups as well as applications including communications, radar and more. This ruggedly designed amplifier provides unconditional stability and built-in self-protection against reverse polarity, over voltage and overheating. It is capable of withstanding a VSWR of 3:1 at 20W P<sub>OUT</sub>. Housed in a rugged aluminum alloy case measuring 6 x 4 x 1", the unit features SMA connectors and an optional heat sink and fan attachment for cooling.

## KEY FEATURES

Feature	Advantages
Rugged design	No damage into a VSWR of 3:1 at 20W output power
Internal protection	High temperature, over voltage and reverse polarity.
Large frequency range	Large instantaneous frequency range covers 6-18 GHz with one amplifier.
High power gain	Enables signal amplification to 10W output without the need for multiple gain stages. The amplifier has a typical power gain of 40 dB at 0 dBm input power.
Unconditional stability	Provides reliable performance independent of input and load conditions.



ELECTRICAL SPECIFICATIONS AT  $T_{\text{MOUNTING BASE}}=+25^{\circ}\text{C}$ ,  $V_{\text{DS}}=20\text{V}$ , 50Ω SYSTEM

Parameter	Symbol	Condition	ZHL6G018G020+ / ZHL6G018G020X+						Units
			Min.	Typ.	Max.	Min.	Typ.	Max.	
Frequency Range	f		6000	—	17000	17000	—	18000	MHz
Output Power	$P_{\text{OUT}}$	CW @ $P_{\text{IN}}=8\text{dBm}$	13.8 41.4	25.7 44.1	— —	8.9 39.5	13.5 41.3	— —	W dBm
Small Signal Gain	$G_{\text{SS}}$	CW @ $P_{\text{IN}}=-30\text{dBm}$	45	57	—	43	48	—	dB
Small Signal Gain Flatness	$G_{\text{SS-FLAT}}$	CW @ $P_{\text{IN}}=-30\text{dBm}$	—	±6	±7	—	±3	±7	dB
Power Gain	$G_{\text{p}}$	CW @ $P_{\text{IN}}=8\text{dBm}$	—	34.5	—	—	33.8	—	dB
Power Gain Flatness	$G_{\text{p-FLAT}}$	CW @ $P_{\text{IN}}=8\text{dBm}$	—	±5	±5	—	±5	±5	dBm
Noise Figure	NF		—	8	10	—	8	10	dB
Input Return Loss	IRL	CW @ $P_{\text{IN}}=-30\text{dBm}$	7.5	15	—	7.5	19	—	dB
Harmonics	H2, H3	CW @ $P_{\text{IN}}=8\text{dBm}$	—	-10	—	—	-10	—	dBc
Spurious Signals	Spur	CW @ $P_{\text{IN}}=8\text{dBm}$	—	—	-60	—	—	-60	dBc
DC Supply Voltage	$V_{\text{DC}}$		—	20 <sup>1</sup>	22	—	20 <sup>1</sup>	22	V
DC Supply Current	$I_{\text{DC}}$	CW @ $P_{\text{OUT}}=40\text{dBm}$	—	5	7	—	5	7	A

1. Recommend Operating Voltage

## MAXIMUM RATINGS

Parameter	Ratings
Operating Mounting Base Temperature	-20°C to +60°C
Storage Temperature	-55°C to +100°C
DC Voltage	22V
Input RF Power (no damage)	+10 dBm
Ruggedness through all phases at $P_{\text{OUT}}=20\text{W}$ CW	VSWR=3:1, 2 minutes



COAXIAL SOLID-STATE

# High Power Amplifier

**ZHL6G018G020+**  
**ZHL6G018G020X+**

Mini-Circuits

50Ω 20W 6 to 18 GHz

## OUTLINE DRAWING FOR MODELS WITH HEATSINK & FAN (ZHL6G018G020+)

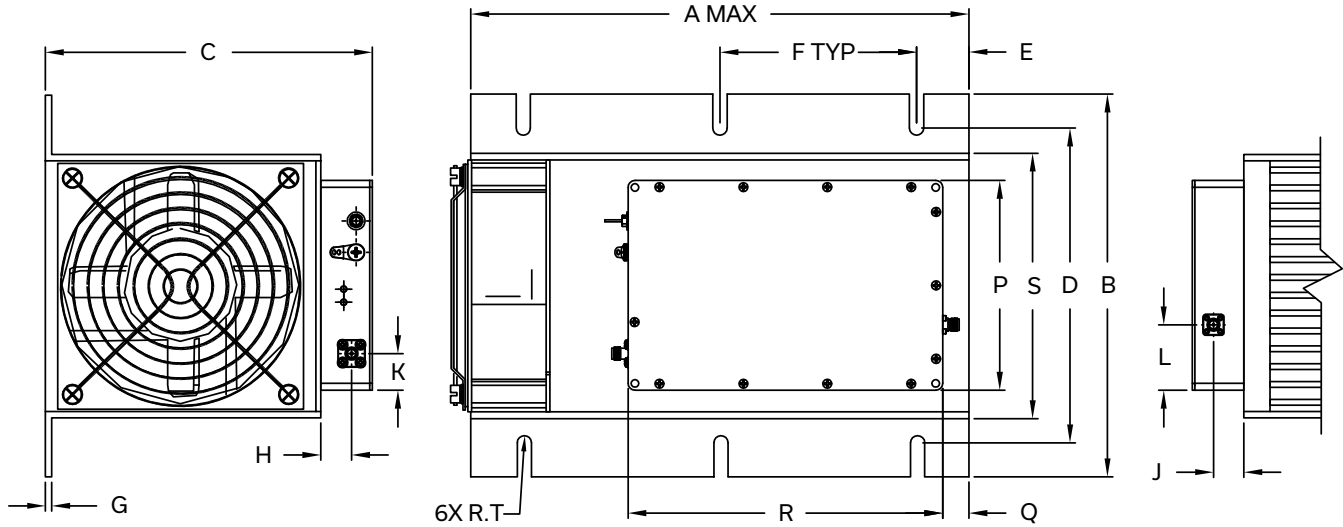

## MOUNTING INFORMATION FOR MODELS WITHOUT HEATSINK & FAN (ZHL6G018G020X+)

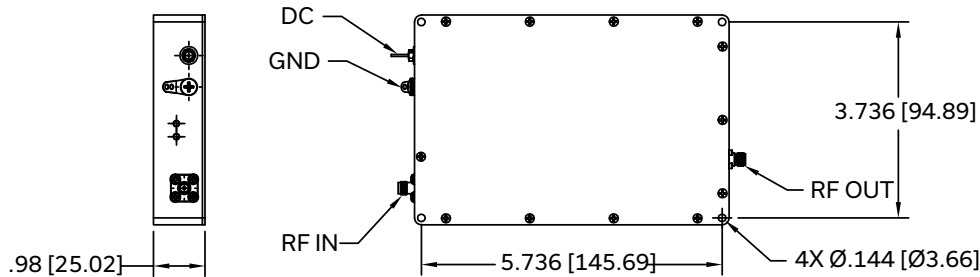

Dimensions in inches [mm]

## OUTLINE DIMENSIONS

	A	B	C	D	E	F	G	H	J	K	L	M	N	P	Q	R	S	T	wt
inches	9.85	7.3	6.23	6.00	1.0	3.75	0.13	0.59	0.58	0.70	1.25	—	—	4.00	0.50	6.00	5.1	0.135	grams*
mm	250.19	185.42	158.24	152.40	25.40	95.25	3.30	14.99	14.73	17.78	31.75	—	—	101.60	12.70	152.40	129.54	3.43	4265

\*580 grams without heatsink





### TYPICAL PERFORMANCE DATA/CURVES

Frequency (MHz)	Power Gain (dB)	P <sub>SAT</sub> (dBm)	Supply Current (A)
6000	34.00	42.00	4.61
7000	35.75	43.75	5.78
8000	35.31	43.31	5.67
9000	35.69	43.69	5.98
10000	36.59	44.59	6.44
11000	37.26	45.26	7.30
12000	37.15	45.15	6.95
13000	36.70	44.70	6.62
14000	36.24	44.24	6.38
15000	36.01	44.01	6.71
16000	36.23	44.23	6.73
17000	35.63	43.63	5.45
18000	32.38	40.38	4.98

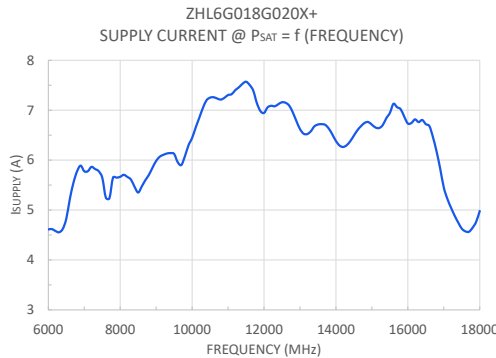
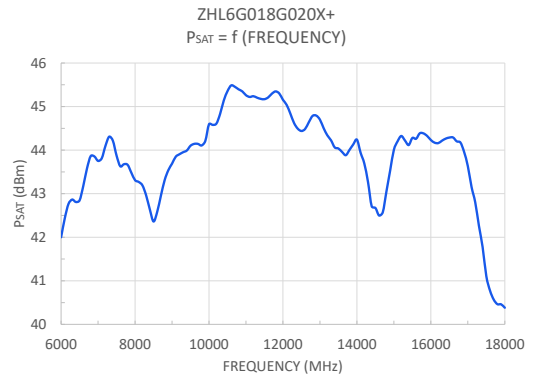
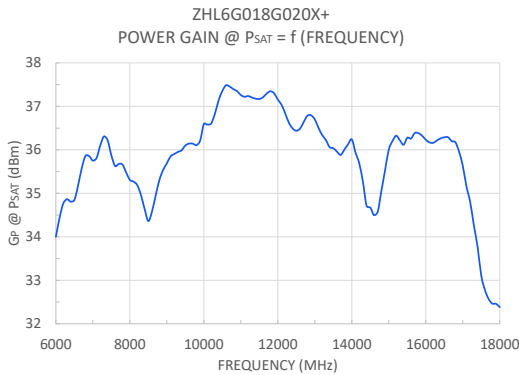

#### NOTES

- A. Performance and quality attributes and conditions not expressly stated in this specification document are intended to be excluded and do not form a part of this specification document.
- B. Electrical specifications and performance data contained in this specification document are based on Mini-Circuit's applicable established test performance criteria and measurement instructions.
- C. The parts covered by this specification document are subject to Mini-Circuits standard limited warranty and terms and conditions (collectively, "Standard Terms"); Purchasers of this part are entitled to the rights and benefits contained therein. For a full statement of the standard terms and the exclusive rights and remedies thereunder, please visit Mini-Circuits' website at [www.minicircuits.com/terms/viewterm.html](http://www.minicircuits.com/terms/viewterm.html)