

REVISION Y

DO NOT SCALE FROM THIS PRINT

DIMENSIONS ARE IN INCHES		UNLESS OTHERWISE NOTED	TOLERANCES ARE:	TITLE:	DWG NO:
ONE PLACE DECIMALS ±.1	TWO PLACE DECIMALS ±.01	THREE PLACE DECIMALS ± .005	FOUR PLACE DECIMALS ± .0020	ZSS-ASSEMBLY	ZSS-1XX-XX-XXX-X-XXXX-XX-XX
				ANGLES ± 2°	SHEET 1 OF 1

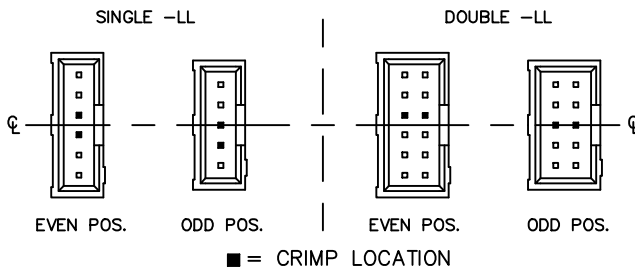
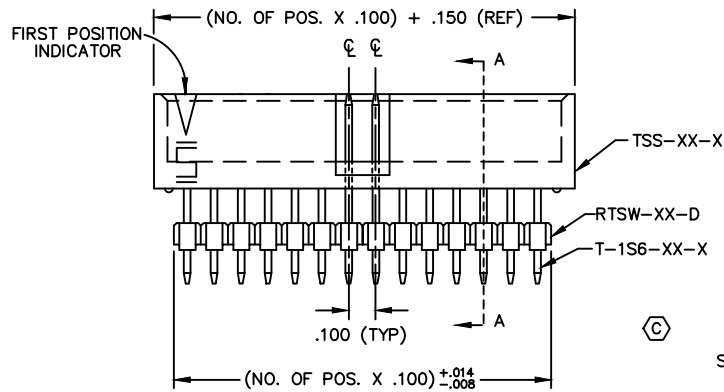
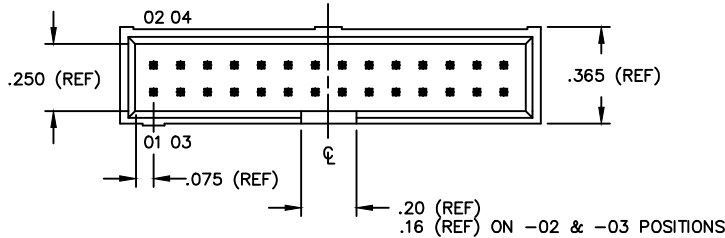
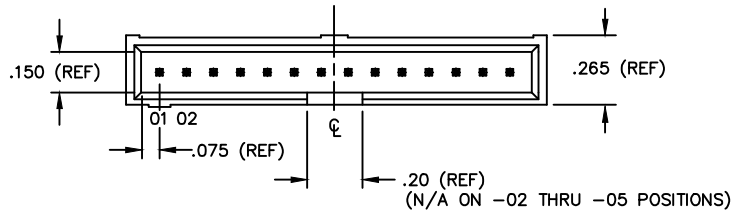

ZSS-1XX-XX-XXX-X-XXXX-XX-XX

NO. OF POSITIONS  
(02 THRU 18, 20, 24, 22, 25, 28, 30, 32, 36)

LEAD STYLE  
SEE TABLE 1

PLATING OPTION

- G: 10μ" GOLD IN CONTACT AREA, 3μ" GOLD ON TAIL
- T: MATTE TIN CONTACT AND TAIL
- S: 30μ" SELECTIVE GOLD IN CONTACT AREA, MATTE TIN ON TAIL
- H: 30μ" GOLD IN CONTACT AREA, 3μ" GOLD ON TAIL
- L: 10μ" SELECTIVE GOLD IN CONTACT AREA, MATTE TIN ON TAIL
- F: 3μ" SELECTIVE GOLD IN CONTACT AREA, MATTE TIN ON TAIL
- STL: 30μ" SELECTIVE GOLD IN CONTACT AREA, (90/10 +/-5%) TAIL (ONLY AVAILABLE IN -06 LEAD STYLE)

POLARIZED OPTION  
SPECIFY POSITION TO BE REMOVED (XX)  
OPTION  
-LL: LOCKING LEAD (SEE SECT. 'A-A' & FIG. 1)  
STACKING HEIGHT  
-450 MIN. STACKING HEIGHT (.535 MIN. BOARD SPACING WHEN MATED WITH SAMTEC SSW)

TABLE 1

LEAD STYLE	TERMINAL	MAX. STACKING HEIGHT	"A"
-01	T-1S6-15-XX-2	.540	.630
-02	T-1S6-09-XX-2	.640	.730
-03	T-1S6-10-XX-2	.740	.830
-04	T-1S6-11-XX-2	.840	.930
-05	T-1S6-12-XX-2	.940	1.030
-06	T-1S6-20-XX-2	1.040	1.130
-07	T-1S6-13-XX-2	1.140	1.230
-08	T-1S6-19-XX-2	1.240	1.330
-09	T-1S6-14-XX-2	1.340	1.430

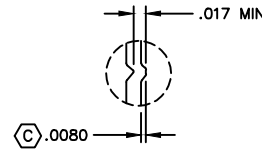

CRIMP DETAIL  
SCALE: 2x  
[TYP- ALL CRIMPS]

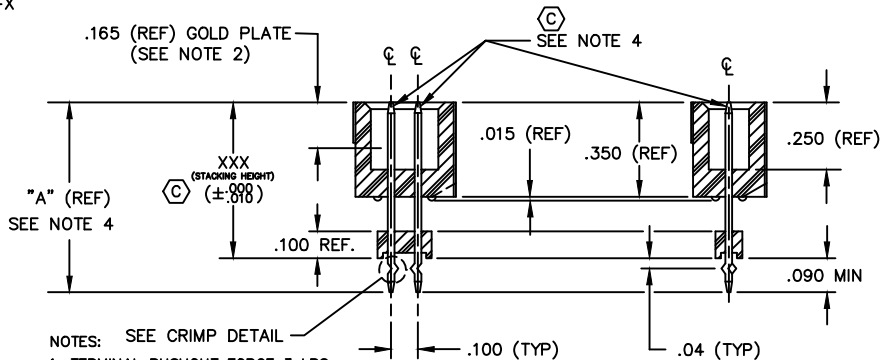

NOTES: SEE CRIMP DETAIL

1. TERMINAL PUSHOUT FORCE 3 LBS.
2. ASSEMBLE GOLD PLATE END AS SHOWN.
3. ( ) REPRESENTS CRITICAL DIMENSION FOR STATISTICAL PROCESS CONTROL.
4. TERMINALS TO BE FLUSH TO .010 BELOW TOP OF SHROUD.
5. INSULATOR MATERIALS: PBT, UL 94 V0
6. FOR ADDED MECHANICAL STABILITY, SAMTEC RECOMMENDS MECHANICAL BOARD SPACERS BE USED IN APPLICATIONS WITH GOLD OR SELECTIVE GOLD PLATED CONNECTORS. CONTACT IPG@SAMTEC.COM FOR MORE INFORMATION.
7. MAX ALLOWABLE CUT FLASH .020.
8. PARTS TO BE PACKAGED IN LAYER.

**PROPRIETARY NOTE**  
THIS DOCUMENT CONTAINS INFORMATION CONFIDENTIAL AND PROPRIETARY TO SAMTEC INC. AND SHALL NOT BE REPRODUCED OR TRANSMITTED TO OTHER DOCUMENTS OR DISCLOSED TO OTHERS OR USED FOR ANY PURPOSE OTHER THAN THAT FOR WHICH IT WAS OBTAINED WITHOUT THE EXPRESSED WRITTEN CONSENT OF SAMTEC INC.

**samtec**

520 PARK EAST BLVD. NEW ALBANY, INDIANA 47150  
PHONE (812) 944-6733 P.O. BOX 1147  
CODE 55322

MADE BY:  
TIM PLUMMER

ZSS-1XX-XX-XXX-X-XXXX-XX-XX  
SHEET 1 OF 1