



COAXIAL WIDEBAND

Digital Step Attenuator **ZX76-50G-30-V+**

50Ω 0 to 31.5 dB, 0.5 dB Step 100 MHz to 50 GHz
6 Bit, Parallel Control Interface, Dual or Single supply voltage

THE BIG DEAL

- Wideband, operates up to 50 GHz
- Immune to latch up
- High IIP3, 50 dBm
- Low Insertion Loss
- Good VSWR, 1.5:1 typ.
- Glitch-less attenuation transitions
- Dual or Single supply voltage: Vdd=+3.3V



Generic photo used for illustration purposes only

Model No.	ZX76-50G-30-V+
Case Style	MS3009
Connectors	2.4 mm

+RoHS Compliant

The +Suffix identifies RoHS Compliance. See our web site for RoHS Compliance methodologies and qualifications

APPLICATIONS

- Test Setup
- 5G
- Satellite Communications
- X band, S band, C band, KU band, and K band Radars
- EW Test Sets

PRODUCT OVERVIEW

The ZX76-50G-30-V+ is a 50Ω Digital Step Attenuator that provides adjustable attenuation from 0 to 31.5 dB in 0.5 dB steps. The control is a 6-bit parallel interface, with a single positive supply voltage. The model is produced using a unique unibody case package for ruggedness and operation in tough environments.

KEY FEATURES

Feature	Advantages
Wideband operation, specified from 100 MHz to 50 GHz	Can be used in multiple applications such as communications, satellite and defense, reducing part count. Able to work up to 55 GHz.
Parallel control interface with wide control voltage range	Uses a simple parallel control interface with no clock required.
Good VSWR, 1.5:1 typ.	Eases interfacing with adjacent components and results in low amplitude ripple.
Glitch-less attenuation transitions	The ZX76-50G-30-V+ employs novel architecture to reduce the RF output power spikes during attenuation transition to 0.3 dB typ thus reducing noise in the system and eliminating the risk of a transient spike damaging sensitive components in the system.
Positive and negative power supply. Single positive supply is available	The use of a single positive supply simplifies power supply design. An internal negative voltage generator supplies the desired negative voltage. Single positive supply results in excellent spurious performance. For applications that require the lowest possible spur performance negative voltage can be applied externally to bypass the internal negative voltage generator.
Power Supply +2.3 to +5.5 V	Model suitable for both 5V and 3.3V systems applications with no voltage dividers or multipliers needed.

**RF ELECTRICAL SPECIFICATIONS, 100 MHz - 50 GHz, T_{AMB}=25°C, V_{DD}=+3.3V**

Parameter	Frequency (GHz)	Min.	Typ.	Max.	Units
Insertion Loss @ 0dB Attenuation Setting	0.1 - 15	—	3.25	5.50	dB
	15 - 35	—	6.00	7.00	
	35 - 50	—	8.00	9.50	
Accuracy @ 0.5 dB Attenuation Setting	0.1 - 15	—	0.45 ± 0.15	—	dB
	15 - 35	—	0.40 ± 0.15	—	
	35 - 50	—	0.35 ± 0.15	—	
Accuracy @ 1 dB Attenuation Setting	0.1 - 15	—	0.85 ± 0.25	—	dB
	15 - 35	—	0.8 ± 0.3	—	
	35 - 50	—	0.6 ± 0.3	—	
Accuracy @ 2 dB Attenuation Setting	0.1 - 15	—	2.3 ± 0.3	—	dB
	15 - 35	—	2.4 ± 0.4	—	
	35 - 50	—	2.4 ± 0.6	—	
Accuracy @ 4 dB Attenuation Setting	0.1 - 15	—	4.15 ± 0.15	—	dB
	15 - 35	—	4.1 ± 0.2	—	
	35 - 50	—	4.0 ± 0.3	—	
Accuracy @ 8 dB Attenuation Setting	0.1 - 15	—	8.3 ± 0.3	—	dB
	15 - 35	—	8.5 ± 0.5	—	
	35 - 50	—	8.3 ± 0.6	—	
Attenuation level @ 16 dB Attenuation Setting	0.1 - 15	—	16.6 ± 0.6	—	dB
	15 - 35	—	16.9 ± 0.7	—	
	35 - 50	—	17.3 ± 0.9	—	
Attenuation level @ 31.5 dB Attenuation Setting	0.1 - 15	—	33 ± 1.0	—	dB
	15 - 35	—	34.5 ± 1.5	—	
	35 - 50	—	35.5 ± 1.7	—	
Input IP3	2 - 16	—	+50	—	dBm
Input Power @ 1 dB Compression	0.1 - 50	+22	—	—	
VSWR	0.1 - 25	—	1.3	2.5	:1
	25 - 50	—	1.5	2.5	

DC ELECTRICAL SPECIFICATIONS

Parameter	Min.	Typ.	Max.	Units
Positive Supply Voltage, V _{DD}	+2.3	+3.3	+5.5	V
Positive Supply Current, I _{DD}	—	170	250	μA
Negative Supply Voltage, V _{CC}	-3.3	-3.0	-2.7	V
Negative Supply Current, I _{CC}	-40	-16	—	μA
Digital Input High	+1.17	—	+3.6	V
Digital Input Low	-0.3	—	+0.6	V
Digital Input Current	—	10	20	μA
Control Input Low	-0.3	—	+0.6	V
Control Input High	+1.17	—	+5.5	V
Control Current	—	—	400	μA

SWITCHING SPECIFICATIONS

Parameter	Min.	Typ.	Max.	Units
Switching Speed, 50% Control to 0.5dB of Attenuation Value	—	330	400	nsec

ABSOLUTE MAXIMUM RATINGS

Parameter	Ratings
Operating Temperature	0°C to 50°C
Storage Temperature	-20°C to 85°C
V _{DD}	-0.3V Min., +6V Max.
V _{SS}	-3.6V Min., +0.3V Max.
Voltage on any control input	-0.3V Min., +3.6V Max.
ESD, HBM	1000V
Maximum Input Power	+28dBm



Digital Step Attenuator ZX76-50G-30-V+

PIN CONFIGURATION (TOP VIEW)

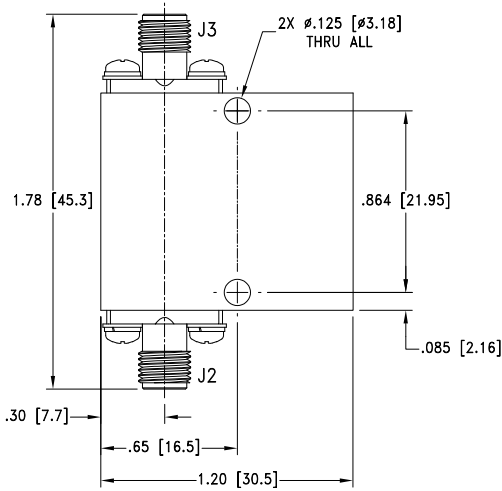

PIN DESCRIPTION

Function	Pin Number	Description
+3.3V	J1-1	Positive Supply Voltage
LE	J1-2	Latch Enable Input
C0.5	J1-3	Control for attenuation bit, 0.5 dB
C1	J1-4	Control for attenuation bit, 1.0 dB
C4	J1-5	Control for attenuation bit, 4.0 dB
C2	J1-6	Control for attenuation bit, 2 dB
C8	J1-7	Control for attenuation bit, 8 dB
C16	J1-8	Control for attenuation bit, 16 dB
+3.3V	J1-9	Positive Supply Voltage
-3.3V	J1-10	Negative Supply Voltage ²
RF in	J2	RF in port ¹
RF out	J3	RF out port ¹

Note 1: Both RF ports are DC blocked with an internal series capacitors.
 Note 2: If Pin J1-10 is grounded the internal negative voltage will be generated.

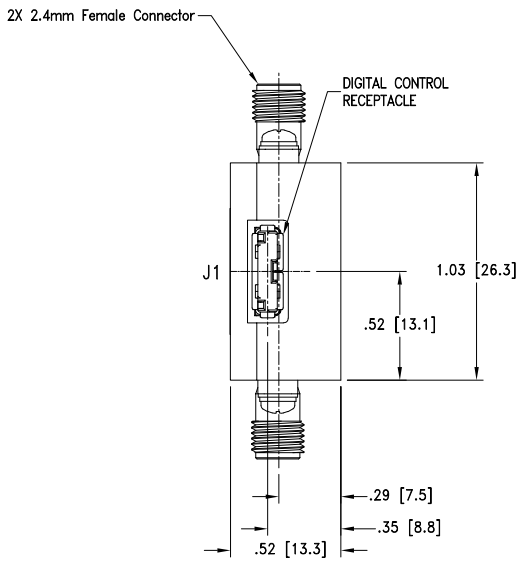



Digital Step Attenuator ZX76-50G-30-V+

SIMPLIFIED SCHEMATIC

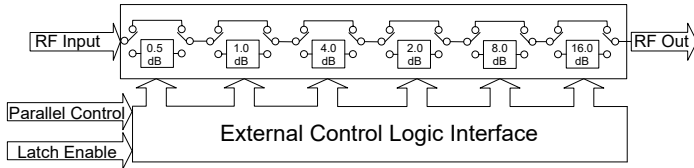

The ZX76-50G-30-V+ parallel interface consists of 6 control bits that select the desired attenuation state, as shown in Table 1: Truth Table.

TABLE 1. TRUTH TABLE

Attenuation State	C16	C8	C4	C2	C1	C0.5
Reference	0	0	0	0	0	0
0.5 (dB)	0	0	0	0	0	1
1 (dB)	0	0	0	0	1	0
2 (dB)	0	0	0	1	0	0
4 (dB)	0	0	1	0	0	0
8 (dB)	0	1	0	0	0	0
16 (dB)	1	0	0	0	0	0
31.5 (dB)	1	1	1	1	1	1

Note: Not all 64 possible combinations of C0.5 - C16 are shown in table

The parallel interface timing requirements are defined by Figure 1 (Parallel Interface Timing Diagram) and Table 2 (Parallel Interface AC Characteristics), and the switching speed.

For latched parallel programming the Latch Enable (LE) should be held LOW while changing attenuation state control values, then pulse LE HIGH to LOW (per Figure 1) to latch new attenuation state into the device.

For direct parallel programming, the Latch Enable (LE) line should be pulled HIGH. Changing the attenuation state control values will immediately change the device's state to a new attenuation value. Direct mode is ideal for manual control of the device (using hardware, switches, or jumpers).

TABLE 2. PARALLEL INTERFACE AC CHARACTERISTICS

Symbol	Parameter	Min.	Units
t_{LEPW}	LE minimum pulse width	10	ns
t_{PDSUP}	Data set-up time before clock rising edge of LE	10	ns
t_{PDHLD}	Data hold time after clock falling edge of LE	10	ns

FIGURE 1: PARALLEL INTERFACE TIMING DIAGRAM

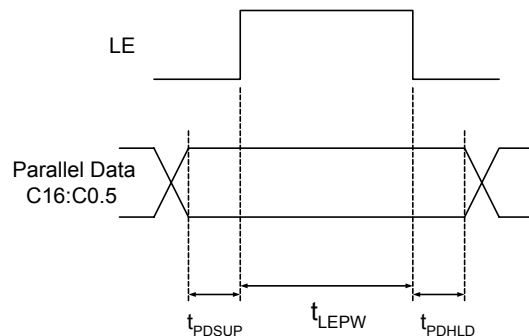

POWER-UP STATE

When the attenuator powers up and LE is logic low, the maximum attenuation is set to 31.5 dB. When LE is logic high, the nominal attenuation selected upon control logics (see Table 1). When LE is logic HIGH upon turn on, the start-up attenuation value will be set based on the control logic in Table 1.



Digital Step Attenuator **ZX76-50G-30-V+**

CBL-5FT-MPD+ CONTROL CABLE

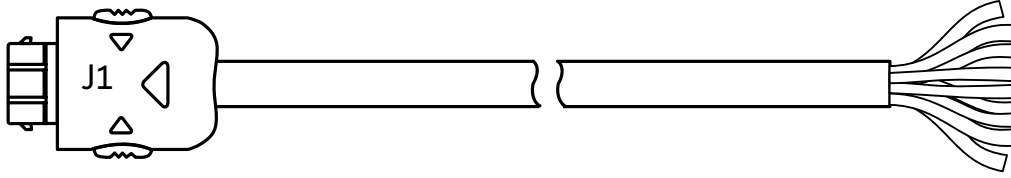

INCLUDED ACCESSORIES

CBL-5FT-MPD+ is a "Pigtail" connector included with every purchase of ZX76-50G-30-V+. CBL-5FT-MPD+ is a shielded cable with stripped wires (#32AWG) on one end and a connector on the other end designed to mate to the ZX76-50G-30-V+. These bare wires enable the customer to assemble their own cable as required to interface with the ZX76-50G-30-V+ (cable length is 4.9ft/ 1.5meters).

CBL-5FT-MPD+ WIRING INFORMATION

J1 Pin Number	Function	Description	Wire Color
1	+3.3V	Positive Supply Voltage	Green
2	LE	Latch Enable Input	Green/Black
3	C0.5	Control for attenuation bit, 0.5 dB	Red
4	C1	Control for attenuation bit, 1.0 dB	Orange
5	C4	Control for attenuation bit, 4.0 dB	Orange/Black
6	C2	Control for attenuation bit, 2.0 dB	Black
7	C8	Control for attenuation bit, 8.0 dB	Red/Black
8	C16	Control for attenuation bit, 16.0 dB	Blue
9	+3.3V	Positive Supply Voltage	White
10	-3.3V	Negative Supply Voltage (ex ground)	White/Black
Shield	-	Shield Braid/ Drain	-

Note: Cable shield connected to case ground.



Digital Step Attenuator ZX76-50G-30-V+

TYPICAL PERFORMANCE DATA

Frequency (MHz)	Insertion loss (dB)	Attenuation relative to insertion loss @Attenuation settings						
		0.5dB	1dB	2dB	4dB	8dB	16dB	31.5dB
100	1.45	0.48	0.91	2.15	4.20	8.14	16.24	32.10
500	1.57	0.49	0.92	2.14	4.21	8.16	16.26	32.12
1000	1.64	0.49	0.93	2.12	4.23	8.17	16.28	32.15
5000	2.16	0.47	0.89	2.16	4.19	8.12	16.27	32.21
10000	3.94	0.39	0.76	2.35	4.08	8.05	16.19	32.27
15000	4.84	0.49	0.92	2.09	4.19	8.27	16.68	32.76
20000	5.12	0.36	0.75	2.04	3.97	8.04	16.37	32.31
25000	5.54	0.29	0.70	2.44	4.14	8.35	16.46	32.03
30000	6.14	0.30	0.68	2.41	4.01	8.30	16.44	32.29
35000	6.00	0.30	0.72	2.43	4.10	8.62	17.08	34.58
40000	6.82	0.30	0.63	2.36	3.94	8.32	16.80	34.11
45000	7.46	0.35	0.49	2.69	3.97	8.54	17.40	34.68
50000	8.06	0.36	0.59	2.35	4.01	8.52	17.59	35.32
53000	9.22	0.35	0.59	2.23	3.94	8.31	17.44	34.51
55000	10.17	0.35	0.74	1.91	3.92	8.31	17.55	35.60

Frequency (MHz)	VSWR In (:1) @Attenuation Settings								VSWR Out (:1) @Attenuation Settings							
	0dB	0.5dB	1dB	2dB	4dB	8dB	16dB	31.5dB	0dB	0.5dB	1dB	2dB	4dB	8dB	16dB	31.5dB
100	1.40	1.28	1.21	1.63	1.10	1.21	1.06	1.09	1.31	1.20	1.12	1.63	1.22	1.08	1.09	1.09
500	1.39	1.27	1.20	1.62	1.09	1.21	1.05	1.07	1.33	1.21	1.11	1.66	1.23	1.06	1.07	1.07
1000	1.40	1.30	1.23	1.62	1.12	1.22	1.10	1.11	1.38	1.26	1.16	1.69	1.26	1.11	1.11	1.11
5000	1.19	1.11	1.08	1.39	1.04	1.13	1.08	1.13	1.22	1.12	1.05	1.50	1.13	1.09	1.11	1.11
10000	1.13	1.08	1.04	1.34	1.21	1.16	1.10	1.22	1.17	1.17	1.24	1.30	1.15	1.25	1.24	1.25
15000	1.47	1.40	1.41	1.54	1.29	1.39	1.14	1.18	1.55	1.45	1.39	1.73	1.40	1.25	1.22	1.22
20000	1.11	1.07	1.04	1.15	1.12	1.12	1.21	1.13	1.31	1.35	1.42	1.02	1.18	1.33	1.31	1.32
25000	1.48	1.46	1.36	1.53	1.51	1.30	1.49	1.52	1.62	1.67	1.77	1.26	1.43	1.63	1.58	1.58
30000	1.64	1.64	1.74	1.56	1.69	1.73	1.42	1.63	1.40	1.35	1.36	1.67	1.51	1.55	1.58	1.56
35000	1.53	1.58	1.59	1.33	1.44	1.39	1.36	1.35	1.26	1.22	1.15	1.56	1.30	1.26	1.29	1.28
40000	1.30	1.33	1.31	1.17	1.23	1.11	1.21	1.12	1.35	1.34	1.23	1.44	1.20	1.03	1.01	1.02
45000	1.09	1.10	1.05	1.28	1.13	1.30	1.48	1.24	1.10	1.08	1.01	1.32	1.10	1.08	1.08	1.08
50000	1.13	1.11	1.17	1.06	1.15	1.01	1.13	1.08	1.31	1.35	1.31	1.21	1.32	1.12	1.12	1.09
53000	1.89	1.86	1.84	2.02	1.72	1.92	2.15	1.86	2.19	2.25	2.12	2.01	2.17	1.70	1.70	1.71
55000	2.35	2.26	2.33	2.27	1.92	2.07	2.25	1.90	2.68	2.75	2.71	2.18	2.68	2.20	2.20	2.14



Digital Step Attenuator ZX76-50G-30-V+

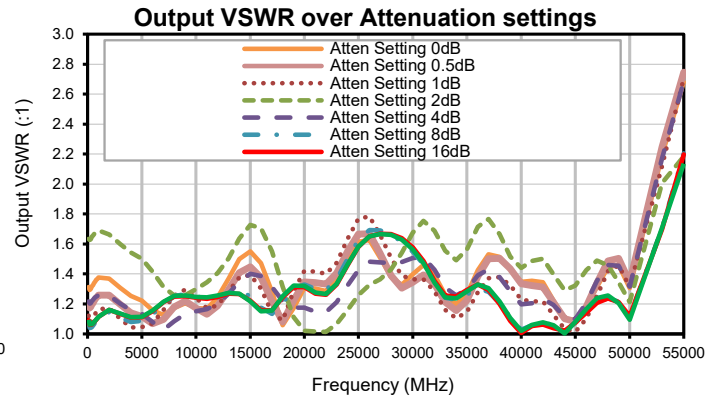
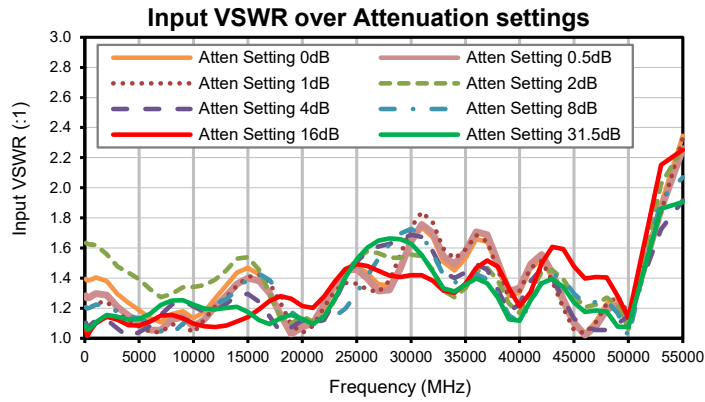
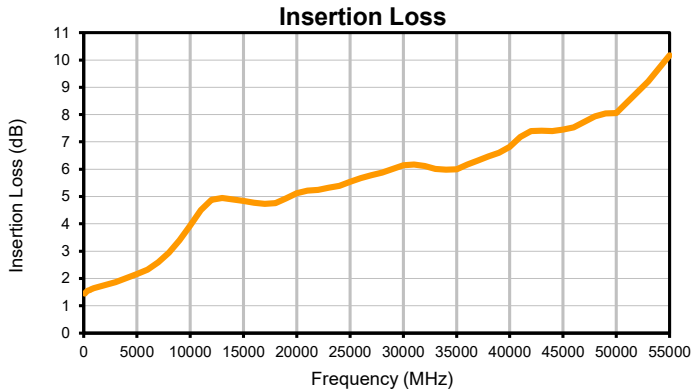



Digital Step Attenuator **ZX76-50G-30-V+**

ORDERING INFORMATION

Model	Description
ZX76-50G-30-V+	Digital attenuator - Dual or Single Supply Voltage

Included Accessories	Part No.	Description
	CBL-5FT-MPD+	5 ft. (1.5M) Control Cable

NOTES

- A. Performance and quality attributes and conditions not expressly stated in this specification document are intended to be excluded and do not form a part of this specification document.
- B. Electrical specifications and performance data contained in this specification document are based on Mini-Circuit's applicable established test performance criteria and measurement instructions.
- C. The parts covered by this specification document are subject to Mini-Circuits standard limited warranty and terms and conditions (collectively, "Standard Terms"); Purchasers of this part are entitled to the rights and benefits contained therein. For a full statement of the standard. Terms and the exclusive rights and remedies thereunder, please visit Mini-Circuits' website at www.minicircuits.com/MCLStore/terms.jsp