

Power Inductors – RFC0810 Series



- Low cost, high current power inductors
- 34 inductance values; 33 μ H to 18 mH
- Flame retardant polyolefin wrap to protect the winding.

Core material Ferrite

Terminations RoHS compliant tin-silver over tin over copper over steel. Other terminations available at additional cost

Environmental RoHS compliant, halogen free

Weight 2.0 – 2.3 g

Ambient temperature -40°C to $+85^{\circ}\text{C}$ with (40°C rise) Irms current.

Maximum part temperature $+125^{\circ}\text{C}$ (ambient + temp rise). [Derating](#).

Storage temperature Component: -40°C to $+125^{\circ}\text{C}$.

Tray or tape packaging: -40°C to $+80^{\circ}\text{C}$

Moisture Sensitivity Level (MSL) 1 (unlimited floor life at $<30^{\circ}\text{C}$ / 85% relative humidity)

Failures in Time (FIT) / Mean Time Between Failures (MTBF)

38 per billion hours / 26,315,789 hours, calculated per Telcordia SRA-332

Packaging 150 parts per tray (except parts with 25 mm lead length); Parts with 25 mm lead length: in fanfold tape, 800 parts per box

PCB washing Tested to MIL-STD-202 Method 215 plus an additional aqueous wash. See [Doc787_PCB_Washing.pdf](#).

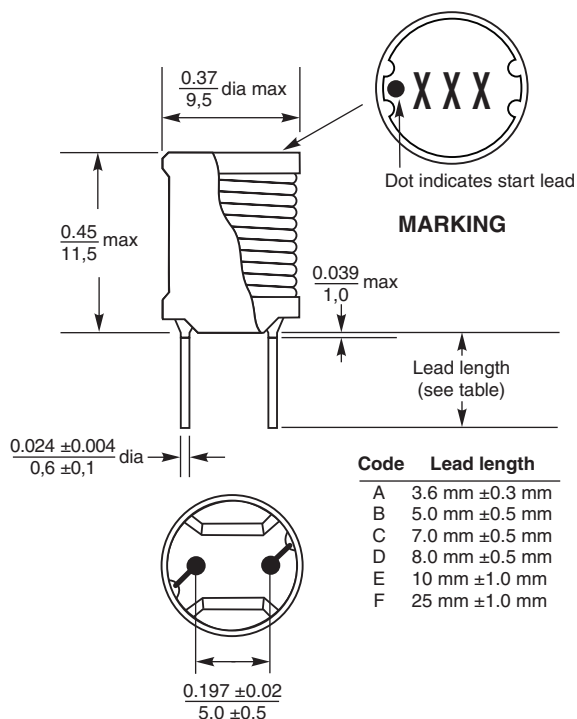

Dimensions are in $\frac{\text{inches}}{\text{mm}}$

Power Inductors – RFC0810 Series



Part number ¹	Inductance ² ±10% (µH)	DCR (Ohms)		SRF typ ³ (MHz)	Isat (A) ⁴			Irms (A) ⁵	
		typ	max		10% drop	20% drop	30% drop	20°C rise	40°C rise
RFC0810B-333KE	33	0.065	0.075	9.0	3.50	3.96	4.25	2.10	3.00
RFC0810B-393KE	39	0.070	0.085	8.7	3.20	3.66	3.95	2.00	2.75
RFC0810B-473KE	47	0.080	0.095	7.5	2.90	3.33	3.60	1.85	2.60
RFC0810B-563KE	56	0.110	0.125	7.3	2.65	3.05	3.27	1.55	2.15
RFC0810B-683KE	68	0.120	0.140	6.3	2.45	2.80	3.02	1.50	2.10
RFC0810B-823KE	82	0.160	0.185	5.2	2.20	2.52	2.72	1.30	1.80
RFC0810B-104KE	100	0.185	0.210	5.0	2.00	2.27	2.43	1.20	1.70
RFC0810B-124KE	120	0.210	0.240	4.9	1.80	2.08	2.24	1.15	1.60
RFC0810B-154KE	150	0.280	0.325	4.1	1.60	1.86	2.01	1.00	1.40
RFC0810B-184KE	180	0.310	0.355	3.8	1.50	1.75	1.88	0.95	1.30
RFC0810B-224KE	220	0.400	0.460	3.0	1.30	1.55	1.67	0.82	1.15
RFC0810B-274KE	270	0.460	0.530	2.9	1.20	1.40	1.51	0.75	1.05
RFC0810B-334KE	330	0.520	0.600	2.6	1.10	1.27	1.40	0.70	1.00
RFC0810B-394KE	390	0.705	0.810	2.4	1.03	1.18	1.28	0.60	0.85
RFC0810B-474KE	470	0.795	0.915	2.2	0.93	1.06	1.15	0.58	0.80
RFC0810B-564KE	560	0.895	1.05	2.0	0.84	0.97	1.06	0.55	0.75
RFC0810B-684KE	680	1.15	1.30	1.7	0.78	0.90	0.96	0.48	0.66
RFC0810B-824KE	820	1.55	1.80	1.6	0.70	0.82	0.87	0.40	0.57
RFC0810B-105KE	1000	1.70	1.95	1.5	0.64	0.73	0.78	0.38	0.54
RFC0810B-125KE	1200	2.35	2.70	1.2	0.58	0.66	0.71	0.33	0.46
RFC0810B-155KE	1500	2.70	3.10	1.1	0.53	0.59	0.64	0.31	0.43
RFC0810B-185KE	1800	3.00	3.45	1.0	0.48	0.55	0.59	0.29	0.41
RFC0810B-225KE	2200	4.10	4.70	0.93	0.43	0.49	0.52	0.25	0.35
RFC0810B-275KE	2700	4.70	5.40	0.89	0.39	0.45	0.48	0.23	0.33
RFC0810B-335KE	3300	6.15	7.10	0.88	0.36	0.40	0.43	0.20	0.29
RFC0810B-395KE	3900	7.10	8.15	0.84	0.33	0.37	0.40	0.185	0.26
RFC0810B-475KE	4700	8.05	9.25	0.78	0.31	0.35	0.37	0.180	0.25
RFC0810B-565KE	5600	9.90	11.5	0.59	0.28	0.31	0.33	0.150	0.22
RFC0810B-685KE	6800	11.5	13.0	0.55	0.26	0.28	0.31	0.145	0.205
RFC0810B-825KE	8200	15.0	17.0	0.48	0.23	0.26	0.28	0.130	0.180
RFC0810B-106KE	10,000	17.0	19.5	0.45	0.21	0.23	0.25	0.122	0.170
RFC0810B-126KE	12,000	21.5	24.5	0.40	0.19	0.22	0.23	0.108	0.150
RFC0810B-156KE	15,000	24.5	27.0	0.36	0.17	0.20	0.21	0.100	0.142
RFC0810B-186KE	18,000	27.5	30.0	0.34	0.16	0.18	0.20	0.097	0.135

1. When ordering, please specify **lead length** and **termination** codes:

RFC0810B-183KE

Lead length: **A** = 3.6 mm ±0.3 mm (special order)
B = 5.0 mm ±0.5 mm
C = 7.0 mm ±0.5 mm (special order)
D = 8.0 mm ±0.5 mm (special order)
E = 10.0 mm ±1.0 mm (special order)
F = 25.0 mm ±1.0 mm, packaged in fanfold tape, 800 parts per box (special order)

Termination: **E** = RoHS compliant tin-silver over tin over copper over steel.

Special order: **S** = non-RoHS tin-lead (63/37).

- Inductance tested at 100 kHz, 0.1 Vrms, 0 Adc on an Agilent/HP 4284A LCR-meter or equivalent.
- SRF measured using Agilent/HP 4191A or equivalent.
- DC current at 25°C that causes the specified inductance drop from its value without current.
[Click for temperature derating information.](#)
- Current that causes the specified temperature rise from 25°C ambient. This information is for reference only and does not represent absolute maximum ratings.
[Click for temperature derating information.](#)
- Electrical specifications at 25°C.



www.coilcraft.com

US +1-847-639-6400 sales@coilcraft.com
UK +44-1236-730595 sales@coilcraft-europe.com
Taiwan +886-2-2264 3646 sales@coilcraft.com.tw
China +86-21-6218 8074 sales@coilcraft.com.cn
Singapore + 65-6484 8412 sales@coilcraft.com.sg

Document 1108-2 Revised 08/03/20

© Coilcraft Inc. 2020

This product may not be used in medical or high risk applications without prior Coilcraft approval. Specification subject to change without notice. Please check web site for latest information.



Power Inductors – RFC0810 Series

Typical L vs Current

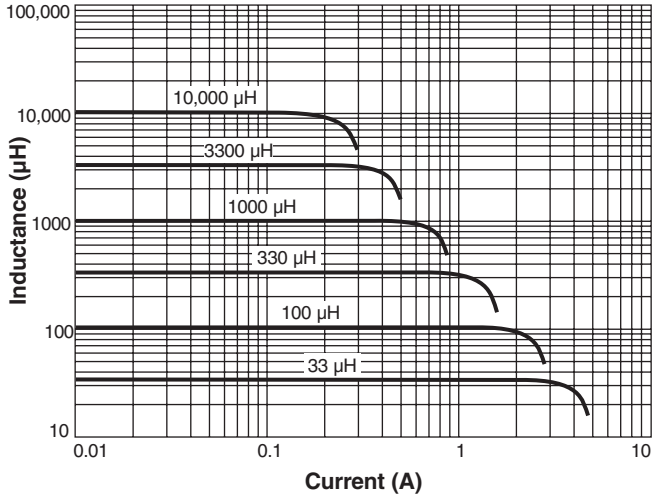

Typical L vs Frequency

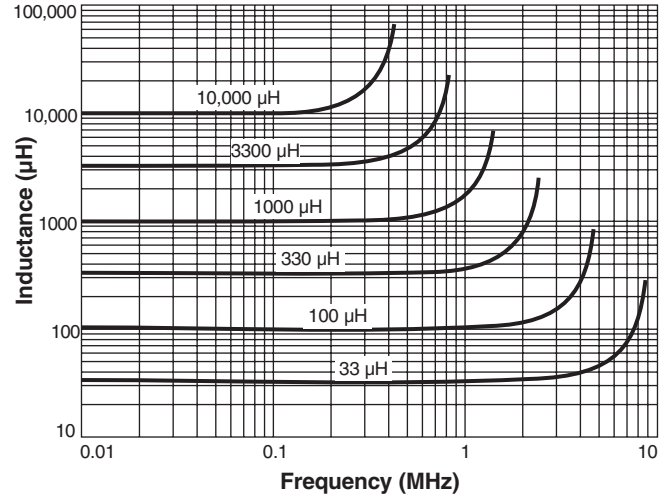

US +1-847-639-6400 sales@coilcraft.com
UK +44-1236-730595 sales@coilcraft-europe.com
Taiwan +886-2-2264 3646 sales@coilcraft.com.tw
China +86-21-6218 8074 sales@coilcraft.com.cn
Singapore + 65-6484 8412 sales@coilcraft.com.sg

Document 1108-3 Revised 08/03/20

© Coilcraft Inc. 2020

This product may not be used in medical or high risk applications without prior Coilcraft approval. Specification subject to change without notice. Please check web site for latest information.